

Middlesex University Research Repository

An open access repository of

Middlesex University research

<http://eprints.mdx.ac.uk>

Asherson Bartram, Claire Estelle (2013) Narratives of mothers in stepfamily situations: an exploratory investigation. Other thesis, Middlesex University.

Final accepted version (with author's formatting)

This version is available at: <http://eprints.mdx.ac.uk/21846/>

Copyright:

Middlesex University Research Repository makes the University's research available electronically.

Copyright and moral rights to this work are retained by the author and/or other copyright owners unless otherwise stated. The work is supplied on the understanding that any use for commercial gain is strictly forbidden. A copy may be downloaded for personal, non-commercial, research or study without prior permission and without charge.

Works, including theses and research projects, may not be reproduced in any format or medium, or extensive quotations taken from them, or their content changed in any way, without first obtaining permission in writing from the copyright holder(s). They may not be sold or exploited commercially in any format or medium without the prior written permission of the copyright holder(s).

Full bibliographic details must be given when referring to, or quoting from full items including the author's name, the title of the work, publication details where relevant (place, publisher, date), pagination, and for theses or dissertations the awarding institution, the degree type awarded, and the date of the award.

If you believe that any material held in the repository infringes copyright law, please contact the Repository Team at Middlesex University via the following email address:

eprints@mdx.ac.uk

The item will be removed from the repository while any claim is being investigated.

See also repository copyright: re-use policy: <http://eprints.mdx.ac.uk/policies.html#copy>

**Narratives of Mothers in Stepfamily Situations:
An Exploratory Investigation**

Claire Estelle Asherson Bartram

Doctor in Psychotherapy by Professional Studies

Awarded by Middlesex University

A joint programme between the Institute of Work Based Learning Middlesex
University and Metanoia Institute

NARRATIVES OF MOTHERS IN STEPFAMILY SITUATIONS AN EXPLORATORY INVESTIGATION

Abstract

Keywords

Family; Stepfamily; Marriage; Co-habitation; Mother; Stepmother; Father; Stepfather; Stepchild; Stepchildren; Gestalt; Therapy; Therapeutic; Evolutionary Theory; Psychotherapist; Psychotherapy; Counselling; Group Dynamics.

This project explores the topography of stepfamily relationships through the prism of the mother, a view as yet rarely explored. Recorded interviews of eleven mothers were examined using narrative, phenomenological, grounded theory methods, within a Gestalt theoretical framework and refined into first person narratives of their experience as mothers and stepmothers.

The overall aim of the research is to develop resources for stepfamily members and inform and educate psychotherapists who work with individuals or couples with stepfamily issues or problems, an area lacking in much information on this at present.

The findings indicate that while many social scientists reject biological determinism within stepfamily dynamics, an acceptance of evolutionary theory opens out the analysis to provide greater understanding of the stepfamily landscape. Further, the study shows that some features of stepfamily dynamics have similarities to the workings of psychotherapeutic groups, and vice versa. Therefore stepfamily situations can be a useful metaphor for therapy group interventions and the possibility exists to develop this theory further as an addition to the existing knowledge of group dynamics.

Products of the project include a series of workshops, development of exercises that illuminate stepfamily issues and the launch of an organisation StepIn ASAP, Advancing Stepfamily Awareness through Psychotherapy.

TABLE OF CONTENTS

PROLOGUE - MY PARENTS	i
ACKNOWLEDGEMENTS	iv
GLOSSARY AND USE OF TERMS IN THIS DOCUMENT	vii
CHAPTER I - INTRODUCTION	1
The Child and the Scientist	1
My Own Family	2
Earlier Work	5
About Stepfamilies	5
Literature and Research on Stepfamilies	7
Evolutionary Theory	9
Aims and Objectives of this project	10
Personal Development	12
Within this Document	13
CHAPTER 2 – LITERATURE REVIEW	17
Definitions and Characteristics of Stepfamilies	17
Research on Parenting in Stepfamily Situations	24
Mothers and Stepmothers	26
A Darwinian Perspective on Stepfamily Relationships	29
CHAPTER 3 – IDENTITY, KNOWLEDGE AND METHODOLOGY	36
Layers of Identity	37
Gestalt; my Therapeutic and Theoretical Home	37
Primary Identity as a Woman and Mother	39
Mixture of Methodologies	43
Heuristic Inquiry – The Research Journey	49

CHAPTER 4 – PROJECT ACTIVITIES AND PRACTICES	64
Criteria for Participation	65
Interviews	67
Exploring the Data	74
Ethical Considerations	82
Anonymity	86
Ownership	91
Benefits	93
Conclusion	94
CHAPTER 5 – FINDINGS	95
Section I – First Person Monologues	95
Clody’s Monologue	97
Bella ’s Monologue	108
Section II – Themes	125
Mothers and Biology in Stepfamily Situations	128
Stepfamily Types	129
Becoming and Being a Mother	134
Mothers as Stepmothers	138
The Cause of Family Breakdown – and the Aftermath	150
Stepfamily Life	158
Summary	163
CHAPTER 6 – PRODUCTS AND DEVELOPMENTS	168
Conference Presentations – Workshops and Groups	169
Advancing Stepfamily Awareness through Psychotherapy	172
Using the Metaphor of a Stepfamily to Understand Group Process	183
Stepfamily Situations and Therapy Group Dynamics	185
Biograms	190
Book Proposal	191
Conclusion	192

CHAPTER 7 – REMAINING ISSUES	193
Discussion Arising from Themes	193
Changes to Project Design	199
Context, Limitations and Strengths of this Project	202
Biases of the Interview Process	209
Verification and Validity	214
Contribution to the Field	221
Conclusion	225
BIBLIOGRAPHY	233
APPENDICES - CONTENTS	242
APPENDIX I - PARTICIPANTS	405
Introducing the Participants	245
Biograms	248
Monologues	256
Extracts from Analysed Transcripts	392
APPENDIX II – PROJECT DESIGN AND DOCUMENTS	405
Original Design From Learning Agreement	405
Extract from Transcript of Focus Group	407
Documents Relating to Research	421
APPENDIX III – INFLUENTIAL BOOKS, SEMINARS AND PEOPLE	425
Women’s Ways of Knowing – Separate and Connected Knowing	425
Gestalt and Evolutionary Theory	429
Specialist Seminars and CARPP Conference	435
APPENDIX IV – PRODUCTS ARISING FROM PROJECT	453
i) Workshops and Groups	453
ii) StepIn ASAP	464
iii) Book Proposal	473
APPENDIX V - FAIRY AND FOLK TALES	479

PROLOGUE - MY PARENTS

If I look back to how this project started there are many elements, some of which go back to childhood. Throughout my life I have been engaged in a relationship with my perception of the academic, scientific mind which was represented by my father. This has been an uneasy relationship which has also been confusing as while in the past I rejected the intellectual, scientific, empirical stance, I simultaneously put it on a pedestal. This project has been an opportunity to re-establish a connection with these values and to integrate them both in the product and in my own person, so that what I present here is truly my own, and is created in neither reaction nor obeisance to my father.

I have always said that writing a book would be like knitting a jumper. As long as I didn't stop I would eventually finish it. I have knitted quite a few jumpers and most recently a patchwork blanket. I challenge myself when knitting by choosing patterns that involve many different coloured wools and a variety of stitches; they have been difficult but more interesting to do than plain jumpers and more impressive when completed. My knitting projects have always taken a long time. The patchwork blanket took over three years to make. For some of that time it lay dormant in a cosy mound behind the sofa and was slept on by the cat, so that it became rather hairy.

This project is my equivalent of the patchwork blanket: there have been periods of time when I thought I would never complete it, however I continued to work at it. There were times when my energy and motivation disappeared and I had no sense of them ever returning and others when I was 'firing on all cylinders' and writing in every spare minute. It is the creative culmination of all that I have learnt up to the present time; the outcome of my life-journey. Many life experiences have contributed to this project each of which like a strand of colour have been woven together to make the whole.

I am researching mothers – and if I start with my own mother, then I have to remember how difficult my relationship was with her, how I vehemently did not want to be like her. I hated how she dressed, how she half smiled when she came to

visit me at school, her migraines, her unwillingness to engage with such subjects as death, Jesus or astrology and her generally unadventurous attitude. She in her turn saw me as a difficult teenager – a terrible teenager, someone hard to understand; I upset her, I was unreasonable and emotional. Perhaps – but this is my theory, never substantiated – I reminded her of her more charismatic sister. At the memorial meeting after her funeral, friends and colleagues said “she was a peaceful woman”, my father, typically, took centre stage and contradicted everyone, saying “no she wasn’t”. This was illustrative of their lives together. He took centre stage and she allowed it whilst occasionally remonstrating mildly. I missed seeing fire in her, the ability to take life by the throat and to fight for what she wanted. Perhaps this is unfair. She was after all from a different generation than me and it is easy for me to forget that expectations of women have changed hugely in my lifetime. My grandmother, (her mother) had been forced to give up her career as a teacher in order to marry and it was expected of my mother that she would be similar. In her own way she had rebelled against her family who were ostentatious, religious and superstitious while she was quiet, enjoyed books and appreciated simple beauty. She left university to marry my father and returned when she was about thirty to study sociology. I learnt later that criminology had especially interested her and I find that hard to reconcile with what I knew of her. I can see that there were contradictions in her character that I have never understood.

In any event, although I had some good moments with my mother, I was touched by her and thought her to be a good woman in every sense of the word, she seemed to me incomplete and I was dissatisfied in our relationship. To my regret, this was never resolved in her lifetime.

In contrast I was in love with my father Geoffrey. My original intention was to dedicate my doctorate to him and forget my mother. This seems typical, he was so much easier to love, and was altogether a bigger, bolder character and he naturally expected attention to turn to him; and so I do in this respect have more to say about him. He was a man who flourished in the world of science and intellect and he was

exuberantly creative within his world. However he was less adept in the world of relationships, where he was like a naïve visitor from another planet, who never quite caught on to what happened between people. While he had a big heart and was a generous man, he was awkward and at times his ideas strangely bypassed emotions; I think he believed these were an anomaly and that education, intelligence and culture showed them to be illogical - and therefore unnecessary. When my brothers and I were children, he wanted to pass on his enthusiasm for all things scientific. He would talk to us in what became known as ‘Geoff’s lectures’ about DNA or how batteries worked, or whatever. I found it hard to follow him but wanted to please him and so I would dissemble and became adept at pretending that I understood. Any hint that he wasn’t being understood encouraged him to continue for hours, while his descriptions became increasingly entangled as he tried to explain something that was for him so easy and so fascinating. Even today, I am still likely to pretend that I understand something when I don’t.

Later, when I was a teenager I wanted my father to understand me. I put in a huge effort and was very upset and angry when he was consistently unable to relate to me. Eventually I left home, furious, hurt, and uncontained. The result of all this was that I had a difficult relationship with learning and academic, theoretical writing, although I was happy with experiential exploration and relationships. I thought that theory was beyond me, and secretly felt stupid.

Therefore one aspect of this doctorate is to address these issues by reclaiming my rational mind or as I once described it, to wind it up, oil it, recondition it and get it to work. It is a project inspired by my father to create and research in my own domain which is that of human relationships.

ACKNOWLEDGEMENTS

This project on stepfamilies is the largest, most concentrated piece of work I have ever undertaken. I am delighted to reach a point where it has been written up and an interest in stepfamilies has been sparked among many psychotherapists; people who previously would not have thought about the relevance of this area to their work. I have been supported in the process by people from different areas of my life who have been interested in this work. Writing this would have been a lonely path to tread without them, and possibly not one I would have completed. It is through the collaboration of friends, colleagues and others in this work that I have been able to develop it as far as I have.

First I am grateful to the women – the mothers who participated as interviewees and contributed their stepfamily stories to the project. I have found their stories moving, exciting and thought provoking. I enjoyed meeting them in their homes and appreciated their hospitality and generosity. I hope that they have found being involved personally valuable.

Maja O'Brien from Metanoia Institute gave me honest and direct feedback. She helped me to focus my writing and thoughts, which were at several points *very* unfocused. My thoughts and ideas tend to expand, and my writing at times was literally all over the place. It has therefore been invaluable to me that she showed me how to put like with like in the writing and to source what I was saying and thinking. Paul Barber my external consultant gave me the structure that has enabled me to bring unwieldy material into a presentable shape. He has also insisted on reigning in my 'butterfly brain' and helped me to keep to the point. I am grateful to them both for their support.

My therapist John Andrew Miller has listened to my happiness and despair over this project for the years I have been doing it. It has been an unusual therapy, less about my psyche and more about this project. Thus he has talked with me about my latest thoughts, contributed ideas of his own and introduced me to important writers and valuable contacts in the field. Most importantly he has consistently shown belief in

the project and my ability to achieve it. This has been incredibly important to me as there were stages where I was losing belief in myself. It has been wonderful to work with a therapist who is flexible enough to allow me to use him as a supervisor and confidante as well as an excellent psychotherapist.

Debbie Friedman and Angelika Wienrich are both colleagues and friends who have been involved in different ways with this project and are founding members of StepIn ASAP. As well as the work we have done together, they have both contributed their knowledge, companionship, wisdom and enthusiasm. We have had fun, deep conversations and some good meals in the process. I am continuing to learn about stepfamilies with them and the other members of StepIn ASAP; Jon Blend, Brian Cordrey, Joan Bruggen, Sue Fox and David Zigmund. Our work together is ongoing and I am looking forward to new developments in our organisation.

I am also grateful to other professionals in the field of stepfamilies, especially Patricia Papernow from Cleveland and Claire Cartwright in New Zealand have shown interest in my work. They have been friendly experts with whom I have been able to interact and share my ideas. I have appreciated their approachability and willingness to support my work. Other professionals in the field of Gestalt therapy have supported me through accepting my workshops at conferences and through worldwide email conversations on issues related to this document on the Gestalt_L discussion group. Thanks to John Wymore in New Mexico who turned me on to ideas within evolutionary psychology and others who have shared with me their personal experiences of stepfamily situations.

Every Monday, Wednesday and some Sundays I have been walking with a group of women and men connected with my local health club. The conversations that have taken place have been incredibly useful. Frequently the walk has become a form of mutual supervision and / or inspiration. It's been fun and very healthy. I am grateful to my walking companions: Annette Meadows, Barbara Brookes, Cheryl Moskowitz, Caroline Palmer, Erica Philips and Roger Pratt, Monica Dobson, Monika and John Wray, Joan Lindeman, Louise Emmanuel, Louise Hebron, Jane

and Gordon Hutchinson, Carole Rawlinson; and to the staff who encouraged us all to push ourselves just a bit beyond our comfort zone and attain ever greater achievements; Ben Talbot and Edel Waldran.

The final and most important area of my life is my own stepfamily. That is my husband, children and stepson. My life with them is what inspired this work as it is by being a mother and stepmother that I have learnt first hand what it means to be a stepmother. My granddaughter Kensy (my treasure in Arabic) was born on April 7th 2007. She has been a welcome distraction from my work.

Special thanks go to my husband Dick. He has supported me emotionally and practically throughout the course of this project. He was a key influence in its conception as he encouraged me to attempt to become a doctoral candidate in the first place and then affirmed the usefulness of focusing on stepfamilies. He has worked hard with me on this document, checking, editing, setting deadlines and talking it through with me. He has lived through the drama of my doubts and the elation when I have had a breakthrough and has listened endlessly to my ideas. He has also tolerated my obsessiveness when I have been stuck at my desk for hours on end, irritable when interrupted and unavailable for most ordinary things. Therefore I am extremely grateful to him and feel that without him I would never have completed the work.

Thus this work has been done in collaboration with the many people who have given to this project in various ways. Whether they have been participants in the research, practically worked with me, have spurred me on or have supported me through valuing what I am doing, they have all been necessary contributors. The efforts of those who are visibly and invisibly represented in these pages mean that this is truly a co-created piece of work.

GLOSSARY AND USE OF TERMS IN THIS DOCUMENT

Throughout this document I refer to heterosexual, euro-centric families.

Biological family / birth family	See nuclear family
Biological relationship	Relationships where children are the offspring or progeny of the parents. (mother/father/child)
Experience/Lived experience	<ul style="list-style-type: none"> a) Experiences of people as individual human beings b) Experienced directly through senses and feelings, (sight, sound, smell, taste, touch and emotions)
Experiential	Of or pertaining to experience or observation; based on or derived from experience.
Experiential Learning	Learning by living through or feeling directly.
Father	A biological father – not a stepfather
Gestalt therapy	A form of psychotherapy. Gestalt means Whole in the sense of ‘the whole is greater than the sum of its parts.’
Groups	See therapy groups
Heuristic / heuristic process	A model of the internal process by which data is made sense of.
Mother	A biological mother.
Narrative	<ul style="list-style-type: none"> a) The words people use when talking about their experiences b) The stories people create when producing a tellable account. c) Underlying stories i.e. stories within stories
Nuclear family	Families of a mother, father and at least one

child in which neither party has a child from a previous relationship.

Phenomenology	Events, occurrences, happenings etc. as experienced directly within the self. What is <i>actually</i> seen, heard and felt prior to any interpretation.
Stepchildren	Partner's children from a previous relationship.
Stepfamily	<ul style="list-style-type: none"> a) A family that includes children from one or both partners' previous relationship b) An extended stepfamily network including e.g. ex-partners and their families, and non-resident parents.
Stepfamily household	A household consisting of a stepparent, parent and children.
Step-relationship	Any relationship within a stepfamily situation, where members are not biologically related.
Stepfamily Situation	A group of people who are connected with a stepfamily e.g. to include single mothers or fathers whose ex-partner is in a new relationship, non-resident mothers or father and their families.
Therapy group	A group of people who meet together with a therapist / leader / facilitator; the interaction among the members of the group are assumed to be therapeutic (Reber 1988).
Workshop	A group aimed to explore and educate on particular issues. A workshop may employ similar skills, techniques and exercises as those used in psychotherapy.

CHAPTER I - INTRODUCTION

If this project were a growing tree rooted in different areas of my life then these roots would be the family I grew up in, being a woman and giving birth, the stepfamily I raised my children in, my Gestalt psychotherapy training and work, and the larger field of family change in this country. I start by talking about myself, partly because I will always be my own starting point, but also because I see my own experiences as close enough to other's experiences for them to be informative.

The Child and the Scientist

First, because it is the earliest root, I consider my family of origin and especially my relationship with my father; the story of me as a child and my father as a scientist. It is a story of different world views, of places where two people did not meet and their values were not shared.

Before taking on this project I connected research with my father. He was an immunologist dedicated to discovery through hypothesis and observation. Often he brought his work home in the form of a cage of mice. He shaved their fur and injected them with some substance unknown to me. He then carefully measured their reactions in ordered lists. For him the mice provided observable data, he was curious to discover what he would find but had no feeling for them as living creatures, perhaps in some way like himself. I however was a child and I identified with the mice. I thought they might hurt, that they were trapped and I felt sorry for them. I persuaded him to let me have one to give to my friend. He seemed unable to imagine what I might feel about this. This might sound as if I am castigating my father for being cruel to mice however the purpose of this statement is to show how entirely differently we were in how we related to them. I see that both the child and scientist are 'right' and simply relating to the material from their own frame of reference.

I always felt alienated by the clever, precise, objective and unemotional science which my father loved. He was confident that any important phenomenon was

observable by a detached mind and that to uncover the observable world outside the self was the only valid means of finding truth. Truth was validated by repeatable experiments. As far as I was concerned his view had weight because he was my father. I on the other hand, was an emotional being, who in the face of scientific purity felt misunderstood, inadequate and wrong. I empathised with mice more than scientists. It is therefore understandable that in response I turned my interests to the inner experiences of people, as a way of making sense of myself and the world. However, I always held this secret conviction that my father was right and that I was stupid and over emotional.

The learning I take from this is to see certain truths as subjective in relation to the reality and perspective of the person perceiving. My father and I lived within “divergent realities” (Koerner, Rankin et al., 2004) by which I mean that we had individual and different world views. The concept of individual realities- my own and that of other women in similar positions - is key to how I have approached this project.

My Own Family

The second most important influence is that of my interest in stepfamilies which arose from raising my children for most of their childhood in a stepfamily situation; an experience which opened a pathway towards the experiences of other mothers in comparable situations. Briefly, my first marriage broke down after eight years of continual difficulty. I spent two years as a single parent and then began to live with my current partner who has a son of his own. My children lived with me and my new partner. Their father remained in touch, but arrangements were very much on his terms. I found the stepfamily situation surprisingly upsetting and confusing, as did all the other members of the family. I had no guidelines on what to expect in the situation and was mothering in unknown territory as is often the case for stepfamily members (Papernow, 1993).

Looking back I can see that I had unrealistic expectations of my new partner. I had been attracted to him on two counts, as a woman who wanted a companion and a partner and as a mother, looking for someone to be a good father for my children,

someone who I imagined would be better than their own father and who also would not make the mistakes my own father had. As a woman I was fulfilled in this relationship, as a mother I was deeply disappointed that my partner did not seem to love, or even at times like my children. I compared his behaviour towards them with his son and felt that he indulged him and criticised mine.

Mothering my children in this situation was very painful. I was full of self-doubt and aware of my inadequacies. I had always found it hard to stand up for myself and felt that I easily gave in to men (a legacy from my relationship with my father). I thought that I needed to stand up for my children with my partner and was not managing this which made me feel weak and helpless. I was overwhelmed by different pulls, my need for a relationship and my instincts towards my children, how I felt I should be as a mother and how I had failed to be that. I felt split down the middle, with allegiance to my children and concern for their welfare on one side and the demands of my new relationship on the other.

For many years my children were upset about not living with their father and rejecting and hostile towards my new partner so I would say that our separation and subsequent divorce was also seriously problematic for them. This was direct information from them in that they told me this, argued with me and criticised my new relationship and expressed the thought that if it wasn't for him I would be living with their father. Their wish for me and their father to get back together exacerbated my guilt at having not managed to sustain that relationship. I was less clear about how my stepson felt but when he was living with us he spent a large amount of his time with his friend in another family; behaviour that researchers suggest is due to difficulties in relationships with adults (Cartwright, October 2005, p13). In this case was likely to have been difficulties with my son who shared a room with him.

My partner and I argued with each other about how each of us was behaving with the others' children. It seems that neither of us knew how to stepparent, what to expect in that situation and how to manage our relationship with each other and with our children. The question for me was who came first and I found it hard that my stepson came first with my partner. For a long time I was unable to like him as if he

was an alien intruder competing with me for my partner's attention and upsetting my children. These were feelings I tried to counteract, but time and again situations would arise when I would feel as if he wanted my place and me out of the way; at those times I resented him. These were difficult feelings in that they made me feel that I was bad; a bad person, a bad mother and a bad stepmother. I wanted to hide my feelings as I was ashamed and sometimes I acted on them and then was mortified and attempted to repair my hurtful actions. It was a confusing experience where I no longer knew how to mother my children, how to be a good stepmother, how to care for myself and what was reasonable to demand from my partner.

My most useful support during that period was individual psychotherapy with a Gestalt therapist. My work with her helped me to understand some of the more difficult feelings that had beset me and I was able to think about how best to manage what was taking place in my family. There was an organisation in London the National Stepfamily Association and I worked with them for several years on their telephone helpline for people in stepfamilies. The people who contacted the helpline seemed to feel similarly confused by their situations; they were grateful for guidance and hungry for information.

People from stepfamilies who contacted the helpline and who turned up at my psychotherapy practice clearly wanted support for what was happening in their families. However this was not an issue that was raised in my psychotherapy training, nor was I aware of training in this area for therapists like myself who worked with individuals and couples, other than with the National Stepfamily Association who offered a weekend course. It became something of a cause for me to promote to therapists the importance of knowing about stepfamily issues and to develop psychotherapy based resources for people who had grown up or lived in stepfamily situations. Therefore I started presenting workshops on this area at professional conferences and as part of my therapy practice.

Consistently I have found that people in any family position - biological or step - find stepfamily situations difficult. I hear this in the stories people bring to therapy, people's accounts in day to day life, what other therapists have to tell, researchers

and writers in the field (De'Ath and Slater, 1992; Papernow, 1993; Gorell Barnes, 1998; Cartwright, October 2005).

Earlier Work

My previous research project¹ (Salisbury 2004) aimed to identify the quality of feelings that arose between biological and non-biologically related stepfamily members (Salisbury, 2004). For this I interviewed people who were both parents and stepparents. I found that parents felt differently towards their own children than they did towards their stepchildren. Parents identified with their children, saw in them a reflection of themselves and that they were something to do with them. They also had a physical sense of connection and were tactile with their children. Parents and children felt loyal to each other and had stronger bonds than new people coming into the family which meant that they created an exclusive group. In contrast, relationships between stepparents and stepchildren often felt more distant and critical of each other. Stepparents felt that they had less of a right and ability to influence their stepchildren's behaviour than the child's parents. It often took considerable time for acceptance and an affectionate bond to grow between them; sometimes this didn't happen. These differences were difficult for stepfamily couples to manage between them. My personal experience resonated with these findings.

From this earlier project I took the hypothesis that relationships between biological parents and children have special qualities and are key within stepfamilies. The suggestion that there *is* a specialness in how people feel towards their own children as compared with their stepchildren fit with my *experience* as a mother in a stepfamily. I wondered whether this was true for other mothers in similar situations and how this might contribute to an understanding of stepfamily dynamics.

About Stepfamilies

Stepfamilies are formed by the separation of biological parents and they are born out of the loss of that relationship when one or both of them enter into a new relationship, (Robinson and Smith, 1993). These families in Britain and America are

¹ Practice Evaluation Project

the fastest growing family form and are increasing across Europe (Stewart, 2007; Mignot, 2008; Smith, 2008). The UK census of 2001 showed that ‘10% of families with dependent children in the UK were stepfamilies with over 80 % of stepfamilies consisting of a natural mother and a stepfather’ (2007). In 2004 a report from the Economic and Social Research Council (ESRC) noted that ‘while the nuclear family of two parents and their offspring remains the statistical norm, other family arrangements are becoming more common’ (Ferri, 2004, p21). The most rapidly growing family type was the stepfamily with most stepfamily households consisting of a stepfather, mother and her children (Ferri, 2004). That is, families where mothers are the resident parent.

Although the definition of a stepfamily seems straightforward, stepfamilies encompass many variations of structure (Stewart, 2007). It cannot be assumed that a stepfamily looks like a nuclear family except that one of the adults is a stepparent. For example, adults might be married or cohabiting, one or both adults might have children, children may live full or part-time within a household, both parents may have new partners or one parent might remain single. Additionally a mother or father might be involved in a series of relationships, each one forming a stepfamily situation and may have children with several different partners. The potential for complexity is huge and there is great diversity both within the families and how they are formed (Stewart, 2007). The term ‘stepfamily’ could be seen as misleading and some families may be more accurately described as ‘alternative family structures’.

Because of the numerous variations of structure found in stepfamilies, there are many different definitions and typologies of stepfamilies, some of which are discussed in the following chapter.

Throughout this writing I use a broad definition of stepfamily which includes multi-household (Stewart, 2007) situations and include non-resident parents and children who live part-time with a parent. This is in order to be inclusive of all people key to the stepfamily, whether or not they are resident or in a new relationship with the potential of moving beyond the idea of family as being based on a conventional

nuclear household (Bell, 2001). These terms and others used throughout this document are included in the glossary on page vii.

Literature and Research on Stepfamilies

All stepfamilies start with a triad of biological mother, father and child. Research shows that these relationships frequently deteriorate when parents separate (Hetherington, 2003; Cartwright, October 2005). Non-academic writing on stepfamilies offer experience close vignettes of stepfamily lives as illustrations to the points they are making (Smith, 1994; Wilson, 1996; Salisbury and Walters, 1997; Hayman, 1999; McEvedy, 2005). These writings often aim to provide useful information to people in stepfamily situations. Research on stepfamily situations has tended to focus mostly on issues between stepparents and children rather than on the impact of stepfamily situations on biological parents; i.e. parent child relationships in stepfamily situations (Ganong & Coleman 1994, cited in Cartwright, October 2005). Thus research on the actual experiences of parents in stepfamilies *as people in their own rights* is under represented.

While within the literature on stepfamilies there does seem to be an assumption that biological relationships are different and special in some way, this is frequently attributed to members having a shared history and culture and a previously established relationship (Smith, 1994; Hayman, 1999; McEvedy, 2005). The possible impact of the actual biology is rarely referred to. It is recognised that stepparenting is a difficult role and that stepparents are stigmatised (McEvedy, 2005; Coleman, Troilo et al., 2008). This is often explained as being the effect of myths and fairy tales such as Snow White, or Cinderella which frequently include a stereotypical ‘wicked stepmother’. However as these stories appear world-wide, the question arises where these stories arise from².

² Bettelheim (1976) suggests that wicked stepmothers in fairy tales are representative of a child’s fantasy in dealing with changes in their mother’s mood. ‘the typical splitting of the mother into a good (usually dead) mother and an evil stepmother is not only a means of preserving an internal all-good mother when the real mother is not all-good, but it also permits anger at this bad “step-mother” without endangering the goodwill of the true mother. (Bettelheim, 1991, p69)

A lack of qualitative research on biological relationships was identified in 2000 by Coleman Ganong et al. (2000) who encouraged research ‘that examines the experiences, perceptions and reflections of stepfamily members’ (Coleman, Ganong et al., 2000, p1301). Existing research was seen to be based more on statistics than on personal experiences (Robertson, 2008; Smith, 2008). Thus studies tend to describe the complexities of stepfamily life, while the voices of the family members themselves, other than the author’s are frequently missing.

Cartwright suggests that the scarcity of research on biological relationships in stepfamilies is possibly due to these relationships being taken for granted as established and resilient in comparison with relationships between stepparents and stepchildren which are known to have difficulties (Cartwright, 2008, p208). Since Coleman et al.’s report, she and her colleague in New Zealand (Cartwright and Seymour, 2002; Cartwright, 2005; Cartwright, 2008) have conducted research into the relationships between biological parents and children in a series of studies which involved interviews with therapists, older children and parents (Cartwright and Seymour, 2002; Cartwright, 2008; Cartwright, October 2005).

In a recent study of stepfamilies in the UK (UK New Stepfamilies Study, see Robertson, 2008; Smith, 2008) mothers were identified as pivotal to stepfamily dynamics, taking on many extra tasks in the early days of stepfamily life and as frequently ‘the cause of the stepfamily, to the extent that they have entered into a relationship with a new partner’ and that ‘their role is key to the dynamics and success of the stepfamily’ (Smith, 2008, p171). She echoes others in noting that researchers tend to focus on step-relationships and states that resident mothers and their role in the functioning and well-being of the stepfamily have been ignored (p170). Mothering in stepfamilies therefore is an under-researched yet crucial aspect of stepfamily life (Cartwright and Seymour, 2002; Hetherington, 2003; Stewart, 2007; Smith, 2008). Coleman, Ganong et al. comment that ‘mother-child relationships have received little attention from researchers’ (2000, p1297).

There continues to be relatively little research specifically on mothers in stepfamily situations and what there is tends to focus on the mother-child relationship. An

exception to this can be found with Koerner et al. who validate mothers' separate experiences through the concept of 'divergent realities' (Koerner, Rankin et al., 2004). They describe a mother who re-partners as 'a romantic adult who is gaining a partner but who also must maintain harmony in her existing family system' (Koerner, Rankin et al., 2004, p27).

Overall there has been less interest from researchers on biological relationships within stepfamily situations than there has been on step-relationships (Coleman, Ganong et al., 2000; Stewart, 2007). Mothers in stepfamily situations are also unrepresented, yet they hold an important position in their families. This project therefore offers a unique insight into the experiences of mothers in stepfamily situations.

Evolutionary Theory

The observation that there appear to be differences in how people behave towards their stepchildren compared with their own children has been the subject of a Darwinian perspective on stepfamilies proposed by Daly and Wilson (1998; Mignot, 2008). (Anonymous) Basing their theory on worldwide statistics regarding abuse towards children and taking examples from animal behaviour, Daly and Wilson postulate that the love and loyalty that parents feel for their own children is connected with the evolutionary drive to further their own genes. Thus biological parents have a genetic investment in their own children that stepparents do not. Daly and Wilson give examples from various species of animals who favour their own offspring and reject others (Daly and Wilson, 1998). Evolutionary theory therefore addresses aspects of human behaviour that are akin to many animals and suggests that primitive motivations also underlie human being's more sophisticated behaviours. Daly and Wilson's argument makes sense of strong feelings that many parents and stepparents express in regards to their family situations. Their opinions are controversial within the field as they are seen to be fatalistic and negative, and to reinforce an already existing stigma towards stepparent relationships.

One of the arguments against Daly and Wilson's view is that such theories have the potential for being misused. Historically an evolutionary argument has been used to

assert the inherent inferiority of certain races, and to justify genocide such as that of World War Two (Coleman, Troilo et al., 2008). The bases for Daly and Wilson's arguments are also questioned. For example it is noted that not all animals behave in the same way towards their offspring and that stepfamily myths are most frequently about stepmothers, whereas many stepparents are stepfathers. The suggestion is that negative stories about stepparents create a stigma (Mason, 2000). Feminist critique views our tendencies to see ourselves in our own children as a socially constructed perception (Lawler, 2000). Daly and Wilson in riposte say that those who argue against them are wrong in assuming that "interpersonal attachments are arbitrary social constructions" and that this also has been the basis for inhumane policies regarding child-care (Daly and Wilson, 1998, p65).

Despite these important criticisms an evolutionary perspective offers a valuable contribution to comprehending the nature of powerful feelings that arise within people living stepfamily situations. On a personal level it makes sense of the feelings I had in my own family.

Aims and Objectives of this project

I have found that psychotherapy trainings do not include stepfamily issues in their curriculum, and that therapists are often unaware of the relevance of stepfamily issues to themselves and their clients. There has not for several years been an organisation in this country dedicated to stepfamilies and focusing on a psychotherapeutic approach.

Many therapists like myself work with individuals and couples and are not equipped to work with whole families. However the individuals we meet are connected to their families; either the one they grew up in, or the one they are in now. As individuals stepfamily members inhabit a particular role within their family. They are a mother, a father, a stepchild, a stepmother, or perhaps a combination of these i.e. both mother and stepmother. Therefore mothers – who are the focus of this project - are individuals who contribute to the dynamics of the family as a whole.

While a focus on biological mothers provide an individual perspective on stepfamily situations it also sheds light on the whole family. An important perspective for a

therapist to be holding is that mothers in stepfamilies are dealing with different challenges than if they were within a nuclear family. The special complications that arise for mothers within stepfamilies are also relevant to therapists who work with whole families.

Arising from these contexts the overall aim of this project was to create sensitive and effective *individual* psychotherapy and counselling resources for people in stepfamily situations. The means of doing this was through focusing on the contribution that mothers make to those dynamics and through creating learning forums within which other psychotherapists might build their sensitivity to and understanding of stepfamilies and find effective ways to work with individuals from stepfamily situations in their practice.

Thus the objectives of this project are to:

- a) explore experiences of mothers in stepfamilies, how they make sense of their stepfamily lives and what this can show about stepfamily dynamics.
- b) to work with others in generating knowledge about stepfamily issues.

The activities of the project - outlined in Chapter 4 - follow two distinct but connected areas. In order to fulfil the first objective of gaining understanding about mothers in stepfamily situations, I conducted a phenomenological, narrative inquiry on the experiences of a small group of mothers. I placed the narrative of my own stepfamily experience alongside the narratives of ten other mothers, obtained through phenomenological interviews and explored the transcripts of these in several stages. All the women whom I interviewed have older children that they brought up from an early age in a stepfamily situation.

The second objective has been addressed through the founding of StepIn ASAP Advancing Stepfamily Awareness through Psychotherapy. This is an organisation which involves other therapists (both those working with individuals and families) in building knowledge on stepfamilies, offering a variety of educational and informational forums for psychotherapists and lay people on stepfamilies. Additionally I have continued to run short workshops at conferences.

Personal Development

It has been difficult to write this project up; I remember with some embarrassment telling my supervisor that I thought I would have no trouble with it. At times I have zipped along at speed, only to receive the feedback that my writing is too descriptive, other times I have slowed down to a snail's pace attempting to put together ideas that have arisen from reading and the work.

Arguing with myself was never a good way to proceed. I continually found myself with two paradigms set against each other and which recreated my adolescent struggle with my father. These were the individualistic, imaginative aspects of psychotherapy against the objective logical character of science. I was unable to adhere fully to either of these as I came to see that I was attempting to live up to different sets of beliefs and identities each of which are an aspect of me. I had to find a way through these blocks in order to proceed. In the course of exploring these difficulties I came to recognise my identity of woman and mother as being strongly influential on my methodology and methods (Belenky, Clinchy et al., 1997). I missed this earlier as I had automatically assumed that my ways of gaining knowledge were 'wrong' as described at the beginning of this introduction. Therefore the process of understanding has taken me back to a place of knowing and accepting myself more.

Within this Document

Chapter 2 – Literature Review

The review is divided into three sections. It starts with considering how stepfamilies have been defined and how this is a reflection of attitudes towards them. The second section is a review of current research on stepfamilies, particularly that which focuses on mothers. In the final section I present the debate around evolutionary psychology which states clearly that there are reasons for significant differences between biological and non-biological relationships. Evolutionary ideas are controversial in the field, but I have found them providing a meaningful context for what many people find when living in stepfamilies.

Chapter 3 – Methods and Methodology

This chapter is divided into two sections. The first section is a discussion and description of the feminine, Gestalt influenced mixed methodology that was used for this project. I give a brief description of separate and connected knowing as described in ‘Women’s Ways of Knowing’ (Belenky, Clinchy et al., 1986). This is followed by a description of Gestalt as my therapeutic home and the transferring of psychotherapy skills to my interviewing technique. I describe briefly the main methodologies I have drawn from – Narrative Research, Autoethnography, Grounded Theory and Cooperative Inquiry. Finally I present Paul Barber’s six stages of heuristic research alongside journal entries. This shows the learning process that has taken place alongside of the rest of this project.

Chapter 4 – Project Activities and Practices

In this chapter I describe in detail the methods and procedures that were set out in my learning agreement. This is followed by a description of participants and the different stages of the interview process. i.e. self-interview, pre-interview and main interview. I describe the process of transcription and different stages of exploring the data i.e. by creating monologues, identifying themes, mapping the structure and looking for an essential essence in each interview.

The final section of this chapter is on ethical considerations and the issues that arose during the course of this project. This includes a comparison of ethical issues that

arise in both psychotherapy and qualitative research. Specific issues I comment on are that of an ethical attitude as a researcher and psychotherapist, anonymity, consent among family members and ownership of the words, connected with the question of who benefits from this project.

Chapter 5 - Findings

This chapter is divided into two parts, in order to present the research findings in two forms. The first section of this chapter is the accounts of two mothers presented in first person monologues. I created these monologues through reorganising the transcribed interviews to create temporally consecutive and tellable stories. The narratives are not dramatic, general or scientific, but illustrative, evocative and subjective.

The second section of this chapter presents segments from my own interview interwoven with those of others and organised into themes. The themes are chosen to show how mothers talked about the different relationships in their families. They cover the structures of participant's stepfamilies, how they perceived themselves as mothers and stepmothers, their relationship with key other family members and issues that arose within their families. The method of presentation has been inspired by Cartwright's exploratory investigation of stepfamily living (Cartwright, 2008).

Chapter 6 – Products and Developments

Having presented the research findings which are the outcomes of one branch of this project, this chapter describes the *products* of which there are several and which constitute the other branch. Most of these comprise the development of, or direct provision of, therapeutic support for stepfamily members who approach individual and couples' therapists. The means of doing this has been to involve other psychotherapists in exploring stepfamily situations. Other products that came out of this project are 'tools' that arose in the course of this inquiry and which can be usefully applied to actual practice.

An important product is the organisation StepIn ASAP Advancing Stepfamily Awareness through Psychotherapy (from here on StepIn ASAP). StepIn ASAP is a

developing organisation, unique in the field, that seeks to address a perceived gap in psychotherapy education, as well as providing resources to stepfamily members.

I have also continued to present workshops at conferences and within psychotherapy organisations, devising interventions and exercises that illustrate stepfamily dynamics experientially. Details of these are included in Appendix IV on page 453. Some of this work now comes under the auspices of StepIn ASAP.

A large section is devoted to using the stepfamily as a metaphor for therapy group dynamics. A group I run on this basis is described. A further section takes further the suggested correlation between stepfamily and therapy group dynamics, particularly relating to sub-grouping and the incorporation of new members.

Another ‘product’ is the Biogram. This is a means of illustrating stepfamilies which emphasises biological relationships as opposed to emphasising partnerships and marriage, as previous forms of representation have done. I have used Biograms for research and as an illustrative tool that aids exploration in psychotherapy. Biograms are introduced in Chapter 4 and described more fully in Chapter 6. Appendix I introduces the participants and includes Biograms of all their families (p 233).

Finally I have been working on is a book that provides narratives of people in stepfamily situations, with exercises and questions that explore the content and issues that the stories highlight. It is based on versions of the stories obtained from my research and could be used as a self-help course on stepfamilies.

Chapter 7 – Remaining Issues and Conclusion

This final chapter brings together the various elements of this project and includes considerations not previously discussed. It starts with a discussion of the themes presented in the previous chapter. I follow this with a discussion of how and why I have moved from the original design for this project as set out in my Learning Agreement. The context, limitations and biases of this project are discussed. This includes a detailed consideration of the participants sample and consideration of the impact of my being known as a psychotherapist on the interview content.

A section on verification follows, with extracts of ongoing ‘conversations’ with two participants. Issues of how to validate a project such as this follow, with suggestions for criteria relating to this project.

There are areas for further research that have been identified through this project. This includes a detailed qualitative study of the experiences of other stepfamily roles and relationships. The conclusion is that I *have* succeeded through my work to create a place for stepfamilies in the psychotherapy field and that interest and involvement is growing.

CHAPTER 2 – LITERATURE REVIEW

Publications on stepfamily situations can be roughly divided in three areas. These are: a) informational writings for the general public, some published by organisations such as Relate , Parentline Plus, the Stepfamily Association, and Stepfamilies Scotland, and others by independent writers. b) writings by clinicians and family therapists such as Gorell Barnes (1998) and Robinson and Smith (1993) and Patricia Papernow (1993) who provide theory that is likely to be of interest to therapists and others working in the field, and c) researchers in a variety of fields pertinent to this area: demography, communications, sociology, psychology.

In the following chapter I draw from writers in all these three areas to consider issues of defining stepfamilies, research on parents in stepfamily situations, issues for mothers in stepfamilies and the debate around a Darwinian model for stepfamily relationships. I conclude that this project addresses an area that has had relatively little attention from researchers.

Definitions and Characteristics of Stepfamilies

The word stepfamily covers a diverse range of structures. While it appears clearly defined, on examination definitions change according to context, who is defining, who it is being defined for, and what the definition is being made for. It is apparent that a word which encompasses so many variations can be used by professionals in the area, but that people may not define themselves in the same way. Definitions of stepfamilies vary according to their setting. For example some have been used by government statistical departments presenting family demography in their countries (see Stewart, 2007) and indicate family policies of those governments; others seek to be inclusive, and some have created typologies of stepfamilies. The language can be clumsy hence these frequently complex situations become difficult to talk about.

Stewart (2007) has recently published an audit of diverse stepfamily structures in the United States. Her focus is on non-traditional stepfamilies and routes to stepfamily life other than marriage and divorce (Stewart, 2007, xiii). Her focus has come about partly because in the US census stepfamilies are defined by marriage and households and not by cohabitation. This conservative stance means that there are likely to be many more stepfamily situations than the census has identified. Stewart estimates that in the year 2000 a quarter of stepfamily couples US would have been cohabiting and that this has probably increased since then (Stewart, 2007, p11). Stewart questions the use of the household as being a relative term of reference for stepfamilies and suggests that ‘stepfamily relationships need to be examined both within and *across* households (Stewart, 2007, p113, author's italics).

The census definition in the US differs from that in the UK which *does* include cohabitation in its definition of stepfamilies. The General Household Survey (2005) estimated that at the time of the last census in 2001, (the first to identify stepfamilies³) 38% of all stepfamilies were with cohabiting couples (online Government statistics - accessed 8th December 2008). Government bodies in the UK seem to have been quicker to acknowledge a variety of family forms as prevalent than those in the US – at least publicly. Limitations of government statistics stemming from narrow definitions hide the reality of the nature of stepfamily situations and create an illusion that stepfamilies are more uniform in structure than they actually are.

Definitions of stepfamilies in publications, research and government reports reflect changes in family structure and attitudes towards them. For example Longmans dictionary of twenty years ago does not contain the word ‘stepfamily’. In this definition the word has to be created from its component parts ‘step’ and ‘family’ as follows:

³ A stepfamily is one where there is a child (or children) who belongs to only one member of the married or cohabiting couple. By definition a stepfamily must contain at least one child but a stepfamily with dependent children may be defined as such by the presence of a non-dependent stepchild. (online Government statistics, accessed 8th December 2008)

- Step -** *comb form related by virtue of a remarriage and not by blood (stepparent)*
- Family**
- a) *A group of common ancestry or deriving from a common stock*
 - b) *A group of things related by common characteristics or properties*
 - c) *A group of people living under one roof; a group comprising one set of parents and their own or adopted children (Longman 1984)*

According to this definition a stepfamily is presented as a version of a nuclear family and definitions rest on steprelationships rather than on a household or family group. Marriage in this definition is the only route into gaining the status of ‘step’.

In contrast, the Oxford English Dictionary (online) has a more recent entry:

Stepfamily *A family with one or more stepchildren; a family in which at least one of the adult partners has children from a previous relationship or marriage (though not necessarily) living in the same household; (also) members of such a family (2008).*

This definition acknowledges the existence of stepfamilies as a distinct type of family and includes possible members outside household boundaries. However even this latter definition fails to acknowledge the complex arrangements that can fall under the banner of ‘stepfamily’.

Looking beyond dictionaries there exist a variety of definitions, some of which are long and detailed; it is clear that defining the stepfamily is not straightforward. Stewart (2007) suggests that this is in part due to their variety of form and that family change continues to evolve. In 1984 the UK National Stepfamily Association (NSA) defined stepfamilies as being ‘formed when one or both adults bring children from an old partnership into a new one’ (Batchelor, Dimmock et al., 1994). In the same year in their book on stepfamilies Batchelor et al. expanded this definition in an attempt to include the many varieties of structure that might come under the umbrella title of ‘stepfamily’ as follows:

A stepfamily is created when someone who is already a parent forms a relationship with a new partner who then becomes a stepparent to the children. In some stepfamilies both partners have children who then become stepbrothers and stepsisters. They may not all live in the same household, but some with their other birth parent, creating both a full-time and a part-time stepfamily household. All the children who have connections with a parent and stepparent belong to a stepfamily, and the structure may include two stepparents if both birth parents have formed new partnerships. A stepfamily also exists when the children are adults, even if they were adults when the stepfamily was created by a parent's new marriage or partnership (Batchelor, Dimmock et al., 1994, p10).

More recently, McEvedy (2005), writing for the general public on stepfamilies provides a definition that includes cohabitation, resident or non-resident, gay and/or lesbian couples. She offers a wide definition of a stepparent as someone who is in partnership with another person who has a child.

As the above descriptions suggest stepfamily structures are potentially very complicated. In this vein Robertson (2008) writes:

Trying to provide a simple definition of a stepfamily is difficult because of the great diversity and potential complexity of family relationships in stepfamilies. At the core is the idea that a couple has formed a relationship in which one or both of the partners have children from a previous relationship. However, such a relationship can exist in a number of variations, depending on such factors as the gender of the stepparent, who has children (his, hers, and theirs), the relationship history of either partner (e.g., previously married, never partnered, cohabiting or romantically attached but not living together), and where the children reside (e.g., full time, shared or visiting). (p127)

Gorell Barnes, Thompson et al. (1998), note that there are 'multitudinous paths' that lead to the creation of a stepfamily which then influence the form of the stepfamily, thereby leading to a variety of stepfamily forms. Most stepfamilies would consist of

a minimum of two 'different but overlapping family groups, one linked to the new stepparent and the other to the displaced but not replaced natural parent'(p2).

The concept of displacement suggests that the 'natural parent' *should* be in the place inhabited by the stepparent, that this is their natural place within the household. It does however introduce a concept of geography in that the displaced parent, if alive must be living elsewhere. It can be seen that stepfamily structures are often characterised by physically dispersed relationships. Bell takes this up in her observation that relationships with non-resident fathers often become enmeshed with electronic means of communication 'that make the human non-human-nonhuman-human hubridity of the telephone network part of the network that is the dispersed contemporary family (Bell, 2001, p8).

There is a tendency to define the stepfamily as a version of the nuclear family that contains non-biological members. However this doesn't reflect the reality of stepfamilies which have many possible arrangements with people living within and without the 'stepfamily household' (see Batchelor, Dimmock et al., 1994, p10) and changing memberships of households. Stepfamilies often look very different from nuclear families where biologically related parents and children live together under one roof.

Bell (2001) suggests that professionals hold family images based on nuclear families thereby causing them to perceive 'other arrangements' as 'reconstituted' or approximated in the 'single parent' or 'stepfamily'. She noted that these perceptions do not include new dispersed family forms. Among her descriptions of possible family situations are those who are 'just in relationships with adults who have dependent children and who do not have familial labels as such' (p3). Bell writes using the term 'stepfamily' rarely and she introduces social science terms such as 'fluid families' (Robinson and Nelson, 1997 in Bell 2001) and 'unclear families' (Simpson, 1998 in Bell, 2001). Such language which may be useful for academics is unlikely to be taken up by the general public to describe themselves. However Bell's point that stepfamily situations are new family forms in their own right is important;

it recognises a variety of situations encompassed under the term ‘family’ and moves away from more traditional concepts of what a family is.

It seems that the more complicated a stepfamily structure becomes the more difficult it becomes to talk about. We lack the language to describe variations of relationship of adults in parental positions. As shown above, attempts to define all options become lengthy and unwieldy reflecting the complexity of potential stepfamily situations and academic language is only relevant to other academics. Thus academics and professionals must become distanced in part by how they talk about stepfamilies and yet, given the rapidity of change and difficulties experienced by people in stepfamily situations, there is a need for language that can bridge these worlds.

McEvedy suggests a definition for a stepparent as follows:

Many stepparents are reluctant to own up to the label of stepfamily, believing they are not enough of a practical ‘mother’ or ‘father’ to their stepchildren. This however is missing the point. Your identity as a stepparent has nothing to do with how many meals you’ve cooked or how much kiddie football you’ve played. Your identity as a stepparent is defined by your union with the mother or father of your stepchildren. (McEvedy, 2005)

This is a very broad definition that aims to include people who might not otherwise recognise themselves as stepparents. However there is a question that consistently arises in this field about who is defining what. If a person does not recognise themselves as a stepparent, there is a question about whether it is valuable to label them as such. Possibly uncertainty in relationships towards children of people who are associated through a partnership evokes a need to impose a definition, beyond what is felt by that person or perhaps their partner. As if there is a need to place an adult in a parental position.

Coincidentally, as I was writing this section an example arrived through the following email message from a woman I will call Jenny, considering her own position:

Am I part of a stepfamily? - I hadn't really thought about it. My ex husband had various relationships after our separation but one he actually lived with didn't happen until both my daughters were grown up. I don't think they regarded either of his two second wives (the one after me died of cancer) as their stepmother and neither did I. I had a long term relationship but he never lived with us as he had his own family but sometimes - rarely - as a family we did something with him, a picnic perhaps, but I don't think my daughters regarded him as their stepfather and neither did I. But I suppose there were potential stepparents around! (Mytton, J, 2008)

Jenny's personal definitions includes whether or not a partner is cohabiting, the age of children when a partnership takes place, whether or not the children perceived a partner as a stepparent and the level of involvement of that person. It seems that for Jenny a partner would need to take on parental tasks in order to be seen as a stepparent. I however would consider her family as a form of stepfamily.

Jenny's situation provides an example of a type of family structure identified by Robinson and Smith (1993) where people tend not to recognise themselves as a stepfamily; these are a) when there is difficulty in the parents sustaining a relationship so that they have a succession of partners, b) if either parent remarries (or enters a relationship) when children are adults and c) when a stepparent (usually a father) joins the mother when her children are very young (Robinson and Smith, 1993, p18).

There are many issues in defining stepfamilies which depend on who is defining, for which reasons and the audience or forum within which the definition is being made. Stepfamilies themselves, as highlighted by Stewart's review of different stepfamily forms, including those that are not so easily recognised (Stewart, 2007) are incredibly diverse, and a stepfamily household – comparable to a nuclear family household – is but one possibility for a plethora of new family forms. Many of these are missed by limited rather than broad definitions of stepfamily; a term which

perhaps needs updating to reflect how families have changed and are continuing to change.

Research on Parenting in Stepfamily Situations

While much research on stepfamilies comes from the United States, in this country publications and research are also coming out of the fields of social science, psychology, and family therapy. Nine years ago, Coleman, Ganong, and Fine recommended ‘qualitative work that examines the experiences, perceptions and reflections of stepfamily members (Coleman, Ganong et al., 2000, in Cartwright 2005)’. Until recently stepfamily research has underrepresented parents in stepfamilies, and has been more concerned with stepparenting and parent child relationships.

Stewart (2007) has more recently surveyed research on stepfamilies in her overview of diverse stepfamily forms. She notes that most research has focused on parent/child relationships after divorce, rather than about stepfamilies per se and echoes Coleman et al. by concluding that more research on biological/parent child relationships in stepfamilies is needed (p61). A UK study of new stepfamilies ‘compared the parenting and functioning of mothers in stepfamilies with those in non-stepfamilies’ (Smith, 2008, p155) and involved interviews with 156 mothers in stepfamilies, and 21 mothers in two-parent families (Robertson, 2008; Smith, 2008).

A tendency has been found for parent/child relationships to deteriorate after divorce in stepfamily situations (Bray, 1988; Bray and Berger, 1993; Hetherington and Jodl, 1994, quoted in Cartwright and Seymour, 2002). This was explored further in studies on the relationships between parents and children (Cartwright and Seymour, 2002; Cartwright, 2008; Cartwright, October 2005).

Cartwright and Seymour (2002) in New Zealand conducted interviews with three groups, a) therapists working with stepfamilies, b) young adults who grew up in stepfamilies and their parents and c) children currently in stepfamilies. They identified problems such as children feeling that they lost time with their parents when there was a new partner, that parents and children had different perceptions of

a new partner and that children resented stepparents who took a disciplinary role with them. The outcome from this research was a set of recommendations for parents and stepparents aimed at maintaining the parent child relationship (p11) and at making family transitions easier for children. These include parents giving individual time and attention to their children, for parents to continue in their care-taking role in the stepfamily and for parents to be respectful of the other non-resident parent.

A new publication, the International Handbook of Stepfamilies (Pryor, 2008), compiles stepfamily research coming from a variety of fields worldwide. The content includes international demographics, dynamics within stepfamily households, influences and relationships beyond the household, clinical and legal issues. It brings together many of the most prominent figures in the field. This is the most comprehensive publication on stepfamilies to date in its internationality and scope. It is useful as a research tool for professionals and practitioners, and covers a variety of stepfamily concerns and issues. The handbook brings together the complexities of stepfamilies from different sections of the field so that the multi-dimensionality of stepfamily issues can be seen.

Throughout this publication there are shown to be potential difficulties in all stepfamily positions. For example Pryor describes stepparents as facing stigmatisation and as being caught by demands to be good parents while having limited authority. At the same time relationships between parents and children in stepfamilies are affected by bringing in a new adult to the family (Pryor, 2008, p576). Her conclusion however is optimistic:

In the very best scenarios children in stepfamilies have four parents⁴ who love and nurture them (p584).

As I have previously stated there is relatively little writing or research that speaks to the *experiences* of people in stepfamilies (Coleman, Ganong et al., 2000; Cartwright

⁴ Presumably she means two parents and two stepparents.

and Seymour, 2002). In her conclusion to the handbook, Pryor also expresses a need for this:

As well as the need for sophisticated statistical tools to match their [stepfamily's] complexity.....qualitative studies that are sensitive to the lived reality of stepfamily living are invaluable for informing both theory and larger survey studies (p584).

I now move to consider research into mothers in stepfamilies.

Mothers and Stepmothers

As described earlier, the creation of a stepfamily comes about following the separation of parents, either because they have ended their relationship or because one of them has died. Thus biology is foundational to every stepfamily with parent child relationships being an intrinsic aspect of their dynamic structure. In many cases mothers and fathers began parenting as partners (married or cohabiting) and therefore have relationships with their children that precede the stepfamily situation; however there are exceptions to this. One example is where a father and mother has separated before their child was born and the child raised from birth by another man⁵.

Mothers are defined by having given birth to a child and at least one is present in every stepfamily situation unless she (the mother) has died⁶. While mothers are clearly important stepfamily members, there has been relatively little research on mothers in stepfamilies compared to other aspects of stepfamily life (Stewart, 2007; Smith, 2008). Research that exists has tended to focus on the mother/child relationship in stepfamilies, rather than the experiences of mothers as women and the meaning of this within a stepfamily situation. This reflects something I have found

⁵ Mary, one of the research participants provided an example of this situation. See the account on page 157

⁶Where both partners have children a stepfamily situation may contain two or more mothers.

personally, which is that people seem to associate stepmothers with stepfamilies, but not mothers (see description on page 226). It is worth noting that mothers in stepfamily situations may also be stepmothers but are not necessarily so.

The UK General Household Survey shows that most stepfamilies in this country are stepfather families, i.e. that they consist of a household with a *mother* and a stepfather. Thus in 2005 84% of children in stepfamilies were found to live with their mother and stepfather. In comparison 10% of stepfamily couples live with children from the man's previous relationship i.e. the woman in the household is a stepmother. 6% of stepfamily households contain children from both partner's previous relationships i.e. adult partners are both parents and stepparents (Fido, Gibbins et al., 2006). The figures from the General Household Survey do not indicate the number of single mothers who have boyfriends or who have passed through several relationships; i.e. stepfamily situations whose members may not recognise themselves as such. The International Handbook of Stepfamilies includes a chapter on resident mothers, written by Marjorie Smith from the UK. She notes that in this country there are resident mothers in the majority of stepfamily households.

The reason for the predominance of mothers being the resident parent in stepfamily situations is that they are most likely to become the primary carer for their children after divorce or separation (Ferri, 2004; Smith, 2008). Because this is the usual situation it can be said that mothers are central to the majority of stepfamilies (Smith, 2008) "the glue that holds stepfamilies together" (Ganong and Coleman, 2004 quoted in; Smith, 2008). Mother-centred stepfamilies include a stepfather, or possibly a succession of stepfathers. The father (if he is alive) usually lives outside the household as a non-resident parent⁷. The level at which parenting is shared between mother and father in terms of time spent with their child (children), financial and practical support, varies from family to family (Cartwright, 2008; Pryor, 2008). .

⁷ If the non-resident parent - father or mother - has a new family of their own this creates a series of linked households which children may move between. Because of this, analysis by household is to some extent misleading, suggesting that stepfamilies are discreet households, as are nuclear families.

As well as external factors that support the tendency for mothers to be primary carers, there are internal and societal factors that contribute to this. For example Coleman, Troilo et al. suggest there is a myth of motherhood; characteristics that mothers are supposed to have by dint of their biological connection:

A good mother is characterized by her natural ability to nurture and her unique pleasure in sacrificing her well-being, if necessary, for the good of the child. It is the mother and only the mother who is suitable to care for her child. (Braverman, 1989 quoted in Coleman, Troilo et al., 2008, p374).

This myth which affects all women, whether or not they are mothers casts ‘good mothers’ as self-sacrificing, loving and patient and bad mothers as controlling, cold and rejecting (Hayes, 1996 quoted in; Coleman, Troilo et al., 2008 p374). A further issue for mothers is that they are also women in their own right outside of motherhood (Lawler, 2000). This aspect of their identity can conflict with the demands of motherhood (Winnicott, 1964; Lawler, 2000) and conjure up the spectre of the bad mother.

In their chapter on Stepmothers in the ‘International Handbook’, Coleman, Troilo et al. suggest that the myth of the good mother influences all stepmothers as it does all women (Hayes, 1996 quoted in; Coleman, Troilo et al., 2008 p374). Stepmothers are unable to attain the ‘goodness’ of the mythical mother, and find themselves having to deal with both the myth of motherhood and negative archetypes of stepmothers which are abundant in fairy tales⁸. Coleman et al. describe this as causing stepmothers to feel ‘like failures as women’ (Levin, 1997 quoted in Coleman, Troilo et al., 2008).

In Coleman et al’s view, feelings that differentiate a mother from a stepmother are perceived or constructed, based on expectations⁹. They state that stepmothers can

⁸ See Appendix V for fairy tales that involve mothers and stepmothers.

⁹ This view is contradicted by the Darwinian perspective described in the next section, which suggests that the fact that a stepmother is *not biologically related* to her children will mean that she feels less-loving towards them (Daly and Wilson, 1998).

become close to their stepchildren only if their relationship is *endorsed* by their stepchildren's biological mothers otherwise the stepmother has 'little or no chance of forging bonds with her stepchildren' (Coleman, Troilo et al., 2008, p375, author's italics). In this model, women are seen to identify with 'modes of motherhood' which support or undermine stepmothers' chances of developing close relationships with their stepchildren (Levin, 1997; Nielsen, 1999; quoted in Coleman, Troilo et al., 2008, p375)¹⁰. They describe both mothers and stepmothers as having to contend with powerful myths that influence how they feel about their role as child-carers. Coleman et al. are therefore recognising the importance of mothers and their centrality in the relationship dynamics of stepfamily situations.

Relationship patterns between mothers and stepmothers could be explained by biological considerations. This has been proposed by Daly and Wilson, whose Darwinian model of stepfamily relationships is discussed in the following section.

A Darwinian Perspective on Stepfamily Relationships

One premise that underlies this project is that the biological connections between parents and children are related to strong emotions and feelings that they often have towards each other. This can be seen within stepfamilies where differing biological relationships can bring about conflicting loyalties and such feelings such as competition, jealousy, possessiveness, and a sense of loss.

A strong argument for biology as being the primary dynamic behind the compelling feelings experienced by parents and stepparent has been put forward by evolutionary psychologists Daly and Wilson (1998). Taking worldwide statistics of childhood abuse they suggest that children are at higher risk of abuse from stepparents than

¹⁰ This suggestion does not seem to account for what a mother might feel: for example a mother might feel threatened by a stepmother who their children might love more than they do her; they may feel insecure about letting their children go, or jealous of their ex-partners new relationship. See Amanda's story on page 254 for an example of a difficult relationship between mother and stepmother.

from genetic parents. Supporting this with studies of animal behaviour, they suggest that these findings show parental love represents an *investment* in genetic posterity that is not present for stepparents, hence the greater risk.

The International Handbook of Stepfamilies (Pryor, 2008) presents conflicting stances from researchers in relation to this Darwinian view. Mignot (2008) a social scientist based in France, provides a comprehensive précis of the evolutionary perspective on stepfamilies, however it is dismissed by Coleman et al. in their chapter on Stepmothers (p373) and discouraged by Pryor in her conclusion who comments that this is a negative and pessimistic view (p557).

Mignot; quotes Cadolle (1998) who states that:

the majority of stepchildren admit that they prefer biological parents and the majority of stepparents say that they prefer biological children to stepchildren (Mignot, 2008, p72).

Mignot describes evolutionists such as Daly and Wilson as attempting to explain this phenomenon. He recognises that there is an antipathy towards evolutionary theory among sociologists, who fear biology being used as a justification for oppression of one race by another (p72). Examples of this antipathy arise in the very same volume.

Coleman, Troilio et al. (2008) cite Mason's argument that Darwinism and biology have been used over time to support the oppression of various racial and other groups of people, on the grounds that they are less evolved and biologically structured to be different. Mason suggests that Daly and Wilson are using the same argument to marginalise stepparents and strengthen stigma that already exist in relation to stepparenting (Mason, 2000; quoted in Coleman, Troilo et al., 2008, p373).

Coleman et al. continue their argument to note that while Daly and Wilson state that a child is more likely to be abused by a stepparent than a parent, mothers are the most common abusers of their children (Coleman, Troilo et al., 2008, p273).

However Mignot says:

Although it seems difficult to deny that adults have a much higher propensity to mistreat their stepchildren than their biological children, it is also undeniable that only a tiny fraction of stepparents mistreat their stepchildren (Mignot, 2008, p74).

Additionally Daly and Wilson have stated that while there is a higher rate of children being fatally abused by parents than by stepparents, the relevance to their argument is that the type of abuse is different:

Filicidal genetic parents of both sexes are often deeply depressed, are likely to kill the children while they sleep, and may even construe murder-suicide as a humane act of rescue from a cruel world, whereas homicidal stepparents are seldom suicidal and typically manifest their antipathy to their victims in the relative brutality of their lethal acts (Daly and Wilson, 1998, p34).

All the above researchers acknowledge that far more stepparents treat their stepchildren well than abuse them. This might seem to contradict Daly and Wilson's argument however they produce an evolutionary explanation for this; i.e. that stepparents who mistreat stepchildren are likely to jeopardise their relationship with their partner and therefore be less likely to be able to mate with them (Daly and Wilson, 1998; Mignot, 2008).

A different explanation for parental love towards their children comes from Lawler who, writing in her feminist analysis of motherhood quotes Schneider in stating that:

.....blood relationship are culturally defined as being an objective fact of nature, of fundamental significance and capable of having profound effects, and its nature cannot be terminated or changed (Schneider quoted in Lawler, 2000, my italics).

Lawler describes genes as being *conceptualised* to be a substance that is passed down through generations and from mothers and fathers to their children (Lawler, 2000, p59). Thus special feelings for children and blood kin are *socially constructed*.

The argument that biological or blood relationships are socially constructed to be different from step-relationships is taken up by Coleman et al. who describe mothers as *identifying strongly* with ‘possessive, exclusive modes of motherhood’ (Coleman, Ganong et al., 2000, p375). They thereby suggest that mothers *choose* to identify with different aspects of motherhood and that such feelings are ‘the belief of the mother’. This is opposed to the explanation that such feelings might be the *natural* response for a mother who has to share her children with another woman. These arguments explain feelings that people have towards those they are biologically related to as beliefs, definitions and social constructions, rather than as feelings intrinsically connected with biology.

The argument against evolution and biology, as presented by Coleman et al., Lawler and Pryor seem to deny that there might be innate tendencies in a human being that influence feelings towards and between biological parents and children; (and stepparents and stepchildren). Such arguments oppose Darwinists and geneticists and also seem at odds with thinkers about early relationships such as Winnicott and Stern, both of whom describe a mother as beginning the relationship with her baby while the baby is within her womb (Winnicott, 1960; Winnicott, 1986; Stern, 1998). Therefore biology *must* have a part to play in her feelings.

As shown above many researchers express discomfort at a Darwinian explanation, contending that is a dangerous. The essence of this evolutionary debate is whether the ways people feel towards their biological kin are part of our natural being and therefore unchangeable, or whether they are socially and culturally constructed and therefore more open to being influenced (Daly and Wilson, 1998; Baham, Weimer et al., 2008; Coleman, Troilo et al., 2008; Mignot, 2008). For example Mason (2000) says:

At the end of the day it is only guess-work. There is no genetic map that clearly charts this behavioural territory and recent history has taught us that extending evolutionary theory to contemporary human behaviour can be an exciting, but dangerous game (p262).

While Daly and Wilson comment as follows:

..... [there is a] false dichotomy of "social" versus "scientific" explanations. Subscribers to this dichotomy....think of biological influences as intrinsic and irremediable, to be contrasted with extrinsic and remediable social influences (Daly and Wilson, 1996).

Pryor asserts in her conclusion to the International Handbook that the evolutionary theory offered by Mignot is a grim prognosis for stepfamilies as it claims that 'stepparents of both sexes are biologically programmed to neglect, abuse and even kill their stepchildren' p576). On this matter Daly and Wilson write:

more realistic world views invite more humane attitudes and practices than fantastic ones, because they entail better models of human nature and hence greater sensitivity to human needs and desires (Daly and Wilson, 1998, p66)

and in their conclusion they state that;

The proposition that stepchildren are not loved like genetic children strikes many social scientists as distasteful....This dismissive stance tends to go hand in hand with an assumption that interpersonal attachments are arbitrary 'social constructions'. Is the Darwinian world-view uglier in its implications? We think not.

I find Daly and Wilson persuasive partly because what they have to say fits with my own feelings towards both my children and stepchildren. It would seem that primitive emotions and feelings connected with biology *must* be a part of what takes place within any family and be present for both parents and stepparents, simply because we are biological entities.

Daly and Wilson say of themselves that a Darwinian perspective is more *realist* than negative. I concur with this as to my mind they present an optimistic view that suggests building understanding of what is happening within stepfamilies on what

people are, rather than what people wish themselves to be¹¹. It therefore allows for the potential role of psychotherapy to support people in recognising their more difficult and primitive feelings and thereby having choice to behave differently, rather than be ruled by them unconsciously.

Conclusion

This chapter has been divided into three distinct sections, each drawing from research and writing on stepfamilies.

The first section looks at definition of stepfamilies and shows that they are defined differently according to when the definition was made, who is defining, and what the purposes of definitions are and shows that there is no shared agreement about what exactly a stepfamily is. Additionally many people may not identify themselves as being in a stepfamily situation, although professionals in the field would. People who are connected with stepfamilies but are not part of a stepfamily household are not usually included in stepfamily definitions; for example single mothers, or non-resident fathers. As these people are dealing with stepfamily issues they might be said to be part of a *stepfamily situation* and it is stepfamily situations that I have used for the arena of my investigation. The conclusion is that the term 'stepfamily' is not always useful as it fails to encompass diverse family forms that vary greatly from that of the traditional nuclear family.

The next section considers research that focuses on issues that arise for mothers in stepfamily situations. There are issues that arise specifically for mothers in stepfamilies and also for stepmothers which are connected with strong myths of womanhood, motherhood and stepmotherhood.

The final section reviews a Darwinian model of stepfamily relationships which provides a framework for understanding why people feel and act as they do within stepfamilies. This view is often rejected on grounds that it stigmatises stepparents and is perceived to be negative, however the Darwinian view makes sense of strong

¹¹ An attitude that is entirely commensurate with Gestalt's therapy's concern with the authentic person (Perls, 1973)

relational currents within stepfamily situation and has the potential to normalise some of the more difficult feelings and dynamics that arise within stepfamilies. The controversy surrounding this is part of a larger debate about the root of the 'nature/nurture debate', i.e. 'the relative contributions of experience (nurture, environment, learning and inheritance) or predisposition (nature, heredity, genetic predisposition) to the make-up of an organism, especially a human organism' (Reber, 1988). Researchers and writers seem to lean towards one set of explanations or another rather than to tease out the implications of both, and how they may be intertwined.

Overall there remains more to be understood about good functioning in stepfamilies, the experiences, feelings and motivations of stepfamily members as has been highlighted by several researchers. Despite being central to stepfamilies, mothers are underrepresented in literature and research. Furthermore, there are no studies that focus specifically on the *experiences* of mothers in stepfamilies; an area that this project has taken up. Several studies have commented on the need for more qualitative research on stepfamilies; this was identified in 2000 by Coleman et al. and continues to stand (Pryor 2008). Thus there is a place within the larger body of research for the contribution of an inquiry such as this one.

CHAPTER 3 – IDENTITY, KNOWLEDGE AND METHODOLOGY

This chapter introduces the methodologies and methods that were used in the research activities of this project.

I approached the project as a Gestalt practitioner and as a woman and mother. I found many qualitative methodologies that complement Gestalt therapy (Barber, 2002) and used several in a ‘bricolage’ (Denzin and Lincoln, 2003) or mixed methodology. I chose from these by following the path of my interest in a creative exploration. This mode of procedure was partly influenced by the ‘ways of knowing’ I have developed as a woman and mother (Belenky, Clinchy et al., 1986) as well as being an important aspect of Gestalt practice. (Zinker, 1978)

Thus in the course of this inquiry I have:

- * followed a heuristic process using phenomenological research methods (Moustakas, 1994; Barber, 2002),
- * used reflexivity to gain insight as a researcher (Etherington, 2004),
- * explored the narratives of participants through re-writing their texts, (Kohler Riessman, 1993; Etherington, 2000) and identified themes from these narratives with grounded theory (Glaser and Strauss, 1967)
- * included in the writing autoethnographic fragments of my own experience (Kohler Riessman, 1993; Etherington, 2000; Sparkes, 2002),
- * and created a cooperative enquiry group of psychotherapists to develop an organisation (Reason, 1988; Heron and Reason, 2001).

The whole is a feminine and Gestalt-inspired inquiry (Etherington, 2000; Barber, 2002). It’s methods have emphasised contact, experiential wisdom and the authority of lived experience (Barber, 2006, p18).

Layers of Identity

Gestalt; my Therapeutic and Theoretical Home

As a Gestalt practitioner Gestalt practice and philosophy was a strong influence in my research methodology.

Gestalt is the therapeutic orientation I have been working with since 1991. I have integrated other therapies into my practice but Gestalt remains my therapeutic home. Gestalt has a history of subversive anti-intellectualism and promotes learning by experience. It is an eclectic psychotherapy, that incorporates elements of psychology, phenomenology, existentialism, field theory and Zen Buddhism (among others) into its theory. It is essentially phenomenological in that its practitioners are concerned with the experience that underlies interpretation, i.e. what *actually* takes place, is *actually* seen, and felt in the body and emotions in relation to the external field or context (Perls, Hefferline et al., 1951). Gestalt practitioners draw from their arsenal of knowledge to create explorative experiments aimed to heighten awareness of these sensations.

Gestalt practice links with what Belenky et al. (1986) have called connected knowing in that gestalt therapists seek to meet the other partly through empathic responses. As a Gestalt therapist working with a client I practice a thoughtful awareness, considering what is influencing my responses. I ask myself and the person I am with questions aimed to bring to the surface underlying or hidden narratives. At the same time I remain aware of my own feelings and question how I am responding to or resonating with my client's experience (Perls, Hefferline et al., 1951; Yontef, 1988). This gives me clues to my clients' feelings and less obvious communications that are taking place between us.

The practice of Gestalt psychotherapy can be seen as a specific type of research in the enclosed environment of the rooms where it takes place. Paul Barber puts Gestalt alongside other qualitative methodologies (Barber, 2002). He states that 'Gestalt has influenced and been influenced by many qualitative approaches to

research' (p79) and has gone as far as to describe Gestalt as being a methodology in its own right.

A Personal Description of Self and Other

I can remember as a child wanting to be understood by my parents I thought 'if they know how *I* feel then they would understand'. This now transfers to the stance I hold as a therapist and researcher 'if I know how *they* feel then I will understand'. However neither is entirely true; I can never fully know another person. Since childhood I have been aware that I am alone in my inner world, that my experience is subjective; although as a child I would not have been able to describe this.

I recognise that I am entirely alone within myself and my experience cannot be seen by another and it is impossible to be directly observed by anyone other than me. However what I can know is how I respond to another person as my inner world is influenced by what is outside me.

I have clues towards recognising or understanding another person's experience through my own senses i.e. sight, hearing, touch, emotional feeling and reactions. I recognise what is 'out there' through what I directly experience 'in here' inside of my own skin. Thus while I cannot be inside another person there are times when my reactions in their presence give clues to what they are going through. For example I might feel sad and heaviness when I am with somebody who is grieving, or excited and enlivened as I hear someone talking with enthusiasm. Such responses bring about a powerful sense of connection; a moment when I and another person recognise each other as feeling experiencing beings. The moment which Martin Buber describes as a movement from an 'I – it' relating to an 'I-thou' meeting, where I – it represents separation and 'I-thou' represents connection (Buber, 1958).

Reflexivity

being aware of personal responses and (to be) able to make choices about how to use them.....also to be aware of the social and cultural contexts in which we live and work and to understand how these impact on the ways we interpret our world (Etherington, 2004, p19).

The phenomenological approaches to understanding other's experiences described by Etherington in the above quote, are embedded in Gestalt therapy and research practice (Perls, Hefferline et al., 1951; Zinker, 1978; Yontef, 1988). It is important for Gestalt practitioners to recognise that feelings which arise when in the presence of another person cannot automatically be assumed to connect with that person's experience. Therefore Gestaltists need to practice stepping back from immediate response; and create a space for self examination. In that space a step back, the practitioner asks him or her self 'What are my feelings telling me? How am I responding to this person in front of me? What is causing this response within me? Is it something about me? Or about them? What is the context? It is this reflective activity that Etherington (2004) has called reflexivity.

Primary Identity as a Woman and Mother

While initially it made sense to identify my research methodology with a Gestalt methodology, as I progressed with this project something that I could not put my finger on did not seem right. I became unsure about the rationale for what I was doing, whether Gestalt was still holding as a model and if not what was? At this point in relation to my project I felt confused, worried that I didn't know where I was going and terrified of not being able to bring everything together. At the same time I was continuing to do the work of writing and thinking, but felt in a fog.

The sense of not knowing who I was and of being lost at the same time as being driven along a path was unalleviated until I came across the book 'Women's Ways of Knowing' (Belenky, Clinchy et al., 1997). Within the pages of this book I found encouragement to recognise myself primarily as a woman in that I think as a woman, I have womanly experiences and my world – including my Gestalt - is constructed from a woman's perspective. I saw that being female, a woman and mother, is intrinsic to my way of being in the world and connects me in a *felt* and *known* sense with the other women who participated in this research. This might seem obvious as I was researching mothers in the first place, but the *meaning* of being a mother as a powerful quality belonging to these women was missing in my perception until this shift took place.

This insight clarified for me that the ‘fog’ I had been experiencing was due to missing an important aspect of who I am and that this blocked me from connecting with the research material subjectively. It became apparent that identifying myself as a Gestalt therapist separated me from (most) project participants, while understanding myself as a woman and mother connected me with all participants.

The recognition of my womanliness was a profound shift in understanding the motivations behind how I was approaching research. With this shift I recognised that I practice a feminine Gestalt, which leans towards connecting and to understanding the field through my own phenomenology; and that this corresponds with a way of knowing that Belenky et al. have named as ‘connected knowing’. Thus I know about others partly through what I know of myself; an approach that has been described as a feminine way of knowing (Belenky, Clinchy et al., 1986) and which, (as described in the next section) is also recognised within Gestalt practice as an aspect of field theory (Perls, Hefferline et al., 1951).

These identifications of myself, i.e. ‘Gestalt therapist’ and ‘woman’ can be described as contextual layers of who I am as a researcher. As I have become aware of these contexts what I have been able to see and bring forward from the data has shifted. Thus within the context of myself as a Gestalt therapist I have looked at other women from the perception of myself as a therapist. However when I recognised myself as a woman, I saw clearly that from another perspective I am the same as these women¹² and my insights were more connected (paradoxically more true to Gestalt).

Thinking as a Mother

An example of how I connected with the women in my studies is through considering what it meant for me to be a mother. In *Women’s Ways of Knowing*, the authors introduce the concept of ‘maternal thinking’ i.e. the type of thinking that develops through mothering and caring for children (p201); tasks which entail a

¹² I recognise I have an eclectic identity, of which these are but two. That different aspects of myself jostling for primacy at different times and that each of these connect me with qualities and identities in other people and a variety of approaches to the world.. The idea of a community of selves was introduced by Miller Mair in his Professional Seminar (see Appendix III p438).

characteristic type of learning. The authors observe that mothers acquire much of their mothering knowledge ‘on the job’ and develop ‘interdependence, intimacy, nurturance and contextual thought; values that Belenky et al. have described as being attributed to the feminine. (Bakan 1966; Chodorow 1978; Gilligan 1977, 1979, 1982; McMillan 1982; quoted in Belenky, Clinchy et al., 1997)’.

The concept of maternal thinking resonates with me. I and each of the women I interviewed had been through the powerful experience that only a woman can have; that of giving birth¹³. My own experience of giving birth changed my life dramatically, as from then on my sense of wellbeing was deeply connected with another’s existence. In order to survive it I had to let go of any semblance of care and throw myself into the moment not knowing whether I would live or die. Thus giving birth took me beyond fear. Now, if I am in the presence of another woman in labour (most recently my daughter) the memory is re-evoked so that I find myself unable to hold back from pushing when she pushes. Therefore I can see that the experience of giving birth remains with me, as a dormant physical memory.

A large part of my life has been involved with raising my children. This has required me to be concerned with their survival and wellbeing. Mothering my children has involved the use of non-intellectual modes of understanding such as empathy and imaginative projection in the service of another’s physical, psychological and emotional development. I have needed to put myself to one side in order to care for them and to find creative ways of ensuring that I also attend to my own needs. Through this I have become strong in subjective practices and less developed in objective thought and this is reflected in how I have approached this project and the methods I used.

¹³ While giving birth is an exclusive experience for women, the ways of learning I am expounding are not, they are available to men as well as women. Nor is their recognition exclusive to Belenky et al. who acknowledge inspiration from Peter Elbow (1973).

Connected Knowing and Gestalt Field Theory

The principle of knowing the other through one's own felt bodily sense links with Gestalt field theory and phenomenological research. Gestalt field theory implies that the 'felt sense' of the therapist provides information that is relevant to the entire situation, while phenomenological research seeks a 'felt sense' of phenomena in the person of the researcher (Barber, 2006).

Looking at this research inquiry from a Gestalt theoretical perspective, the contexts within which it has taken place are called the 'field'. In the Gestalt model any observed phenomenon is qualified by how it is being observed and by the person doing the observing (Perls, 1973). It is identified or becomes figural from an undifferentiated mass of data (the ground) through the needs, concerns and perceptions of the observer. Thus recognising myself as a woman has made figural a womanly and motherly dimension which I am now aware of within this project, the narratives of the women I interviewed and the wider world. Prior to that, this dimension of the field was present but out of awareness as part of the undifferentiated ground. Hence the 'fog' I described earlier.

Perls, Hefferline et al. (1951) apply field theory to every aspect of perception. They describe it as the relationship between organism (human being) and environment. They say that it makes no sense to consider an organism separately from the environment in which it exists (p228). For example a human being cannot exist without breathing and without food. Air and food is part of the context or environment that defines a human being; furthermore the human being interacts with this environment, taking in and putting back out into it in a constant exchange. Air is breathed in, oxygen taken from it within the body and returned to the environment as carbon dioxide; food is digested, sifted, some excreted as waste and some utilised for energy and to build the body. At the same time as this is taking place (along with other processes) the person is moving through time, changing constantly and often incrementally. This perspective is the vision of a continually moving, transforming and interdependent world of matter, with all that exists in a constant state of 'becoming'. Perls et al. argue that the same principle applies to psychological phenomena.

Summary of this Section

In this section I have described how both Gestalt as I practice it and mothering as I have learnt it, involve ways of thinking, learning and knowing through action rather than reading, through personal experience rather than second-hand accounts, and through empathy and resonance alongside of observation. Gestalt has provided the philosophical and methodological structure for this project - a theoretical frame that enables me to encompass processes of becoming self-aware and how this impacts the research data. An important aspect of becoming self-aware has meant recognising and valuing myself as a woman and this has led me to see that I have applied skills and understandings largely learnt through mothering to this project. Thus I have been creatively flexible and explorative in my data analysis, I have been intuitive in taking steps knowing what I feel and want to do first before understanding why, I have employed empathic processes as an interviewer, and have been interactive with participants throughout.

Mixture of Methodologies

In the previous section I presented core perspectives that influenced my research. I now turn to the mixture of methods and the methodologies that I drew from.

Using the Self in Research

It has been an important aspect of the research to include myself as fully as possible. Therefore in all the practices this project has involved, I have included my own material along with that of others and have striven to be visible. I was the project designer, a subject in the data, a witness to others stories and the primary research tool as crucible for processing information (Moustakas, 1981; Clinchy, 1996; Denzin and Lincoln, 2005).

Including myself in the research as I have done, acknowledges that I am not separate from what I am researching and that what I find is inevitably subjective in that it has been processed through me and my faculties. What I produce will always be a co-

creation of myself as researcher influenced by the data, with that data also being influenced by me as researcher. I have been transparent about this.

I now turn to the research questions and a brief description of the methodologies used.

Phenomenological Research Questions

The research questions which underpinned the enquiry linked my experience with that of other mothers as follows: ‘What can I learn from talking to mothers who raised their children in stepfamily situations?’ and ‘Have other mothers in stepfamily situations had similar experiences to my own?’ I was hoping through these questions to obtain personal accounts that provided information from beneath the surface of everyday life.

These research questions almost entirely comply with Moustakas’ description of human science research questions which he states should:

- 1 *seek to reveal more fully the essences and meanings of human experience;*
- 2 *seek to uncover the qualitative rather than the quantitative factors in behaviour and experience;*
- 3 *engage the total self of the research participant and sustain personal and passionate involvement;*
- 4 *not seek to predict or to determine causal relationships;*
- 5 *illuminate through careful, comprehensive descriptions, vivid and accurate renderings of the experience, rather than measurements, ratings, or scores (1994, p105).*

Thus the research aspect of this project was a phenomenological investigation into mothers’ experiences. While I was interested in the essence of what each participant was telling me I was also concerned not to lose their individual and separate stories. Therefore I did not follow Moustakas’ methods precisely as I did not want to create a composite description or a synthesis (1994 pp120-124).

Narrative Research

Having established through my research questions that I was interested in women's experiences, I looked for methods that created experience close data. This led me to employ a Gestalt inspired phenomenological form of interviewing (on page 67) which acknowledged the nature of the interview as an interactive meeting between two people and the resulting narrative as co-created. The interviews were recorded and transcribed (see page 65) and these processes provided the research data.

I defined narrative in two ways, as the words people use when talking about their experiences and the stories that they create when producing a tellable account of the past (see Kohler Riessman, 1993 for a summary of definitions of narrative). I recognised narrative not as the event itself, but as a subsequent processing of events; a means of making sense of events when time has passed; a present action that represents the past through the creation of stories that a person can tell others and themselves (Chase, 2005). Narrative can be delivered in lengthy paragraphs or be discovered within shorter phrases.

Working with narrative – people's accounts of themselves - is an aspect of psychotherapy work and therefore familiar to me. In my daily work I encounter narratives of personal experience 'and use them to change lives by retelling and constructing new and more fulfilling ones' (Schafer, 1992; White & Epston 1990, quoted in Kohler Riessman 1993). I worked with narratives because they are the means by which a person externalises their internal experience and accounts for them both to others and themselves. It is therefore a suitable vehicle for obtaining rich data that provides information on feelings, motivations and the stories of people's lives. Etherington describes narrative as representing experience, that is of events, feelings and relationships (Etherington, 2004 p2); as such it can be seen as the bridge from a person's inner world reaching out through the spoken word to other people.

The characteristics of narrative as being both method of inquiry and phenomenon (Etherington, 2000, p295) allow for a co-creation of meaning and an evocative reflection of the gritty visceral quality of experience (Etherington, 2004).

Narrative Analysis views life as constructed and experienced through the telling and re-telling of the story (Bruner 1987, 1990, 1991; MacIntyre 1981 in Etherington p213) and the analysis is the creation of coherent and resonant stories. The analysis does not seek to find similarities across stories, and is not interested in conceptual themes, but instead values the messiness, depth and texture of experienced life. (Etherington p81)

Describing ‘messiness, depth and texture’ through ‘story’ and the actual voices of participants I felt would do justice to the complications and contradictions of mothers’ experiences in stepfamily situations. (Examples of participant’s narratives are presented as First Person Monologues in Chapter 5 pages 95 - 125 and the remainder are also in Appendix I)

The narratives that have informed this project are ongoing. I have sought to maintain a relationship with participants throughout the course of working on this project so that narrative has continued to be co-created. I have sought comments from participants at every stage of the project (as described in Chapter 4), and their thoughts and those of other people I have encountered have been incorporated into the whole work.

Autoethnography

Autoethnography as I have used it is simply the narrative of my own self and an account of my self-exploration as opposed to the exploration of others’ experiences. The intention has been to illuminate my own and others’ experiences of mothering in a stepfamily situation.

As this project included an exploration of myself as a mother in a stepfamily situation alongside that of other women in similar circumstances I felt it imperative to show this in my writing by weaving my own story in with the narratives of other participants. In this way I have hoped that readers will emotionally connect with what participants and I have lived through (Sparkes, 2002, p73). The writing is aimed to inform through words and through what it evokes in the reader. Therefore if the reader feels an emotional resonance with this writing, I have succeeded in

putting them in touch with their own experience and evoking an internal understanding of what I want to communicate beyond the words on the page.

I have included pieces of my own narrative taken from my interview.

Grounded Theory

In the course of exploring the data, I reached a point where I felt taken over with thoughts and feelings connected to each participant as I became involved with their interview material. It was like meeting each of the women individually and becoming involved in deep communication with them one after the other.

Eventually I felt overwhelmed, steeped in stepfamily information but with no idea what to do with it. This was an unexpected difficulty, arising from how I constructed and perceived the project in the first place. I had hoped through my explorations that some focus would naturally evolve, but this didn't happen.

Grounded Theory became part of the mix of methodologies at this stage, as a means of stepping back from being involved with the data, comparing the narratives and searching for common themes. I sought to put the interviews alongside each other in order to extract themes (Glaser and Strauss, 1967; Strauss and Corbin, 1998).

However I did not turn this study into a full grounded theory procedure as the intention was for the project to remain primarily narrative and for participant's voices to be preserved without becoming subsumed within categories (Alvesson and Sköldbberg, 2000).

Strauss and Corbin's ideas appealed to me as they favour an interplay between qualitative and quantitative research (Strauss and Corbin, 1998, p31) which suited my intention to combine creativity and reflexivity with grounded practicality. I found that Grounded Theory was complementary to my Gestalt frame in that it seeks to find themes that arise from within the data as opposed to imposing a theory or themes onto the data.

In presenting the findings from this comparative work, I used the actual words of participants. I felt it important to show what had actually been said rather than my interpretations so that it could be seen how themes had arisen. Therefore the

findings were presented as a combination of narrative and themed analysis. These can be found in Chapter 5 as First Person Monologues (on page 95) and Themed Analysis (on page 129).

Cooperative Inquiry

Working with the data, using narrative, phenomenological methodologies and grounded theory created pages of writing, involved me in thought, developing themes and theory. There needed to be a means of taking the research away from the written page into practical work and to open out from mothers to the other relationships that were contained in stepfamily situations. I particularly wanted to develop useful forums for people in stepfamily situations and other professionals. For this I sought collaborators who would join me in the venture of using my research findings and applying them more widely. I did not seek to lead such a venture but to inspire others to join me in recognising the validity and importance of developing what I call ‘stepfamily awareness’. The vehicle for this was a new organisation, founded by myself in collaboration with two others, called ‘StepIn ASAP; Advancing Stepfamily Awareness through Psychotherapy’. My intention was to use methods inspired by cooperative inquiry (Reason, 1988; Heron and Reason, 2001) to generate ideas and action that would take this work forward.

Peter Reason and John Heron created Cooperative Inquiry as a means of working with others as equal participants in developing theory and action (Reason, 1988)¹⁴. It falls under the banner of Action Research; a family of methodologies which work towards practical outcomes (Reason and Bradbury, 2004). Co-operative Inquiry involves a group of people researching together and being involved as ‘co-subjects’ (Heron, 1988) and this is equal rather than led, decisions are made by the group, the knowledge of the group is pooled and the direction is decided by the group. It might be said that several heads are better than one and an egalitarian group that is jointly owned creates the potential of a ‘whole being greater than the

¹⁴ Cooperative Inquiry has the aim of ‘producing practical knowledge that is useful to people in the everyday conduct of their lives’ and ‘to contribute through this practical knowledge to the increased well-being – economic, political, physical, spiritual-of human persons and communities and to a more equitable and sustainable relationship with the wider ecology of the planet.’ (Reason 2001 p2)

sum of its parts' as the group develops a group culture, learns to think together, creates ways of exploration and so forth. Reason states 'you can't just *set up* a co-operative inquiry group, because co-operative processes have to be negotiated and re-learned by every new group in every new instance. You may be able to establish a group in the spirit of collaboration, with the intent to become a 'full-blown' co-operative inquiry group, but there is nothing mechanical or automatic about whether this intent can be realised' (Reason, 1988).

A full description of StepIn ASAP and activities arising from it can be found in Chapter 6 pp 172-182.

Heuristic Inquiry – The Research Journey

This section is intended to illuminate some of what the research has personally entailed; the heuristic process which framed the implementation of this project. I recorded this aspect of my work in a journal which was a mixture of free writing about how I was feeling, or ideas and themes, dreams that connected how I was experiencing myself within the research, snippets of overheard conversation and notes taken during seminars and meetings.

While I was guided in part by the design outlined in my learning agreement (Asherson Bartram, 2006) but creating a whole Gestalt was something that happened, rather than something I was able to plan. This heuristic process involved the whole of me, as a research method (Moustakas, 1981); a crucible within which the different elements of the project mingled and were reformed.

On the subject of heuristic inquiry Barber writes:

In heuristic inquiry, autobiographical and 'meditative' reflections come especially to the fore (Douglas and Moustakas, 1984) as the researcher questions 'What is my experience of this phenomenon?' and 'What is the essential experience of others who share a similar experience to my own?' Indeed the researcher's effort to travel ever deeper into his/her inner

experiencing of a specific theme surrenders him/her to an experiential journey sign-posted by six interrelating phases: (Barber, 2006, p78).

I see this personal undergoing, this ‘being a research tool’ as the key meaning making method of this project. If it were not described I might give the false impression that this document was born in perfect form with minimal fuss. On the contrary this writing is the result of a long period of living with the material; a pregnancy which has resulted in the rather messy, uncertain birth of this writing, during which time the life of the baby - this project- seemed to be in balance.

I have used Barber’s description of six stages of Heuristic Inquiry (Barber, 2006), alongside a description of research activities, edited journal entries and other writing, to show how I have experienced being the ‘research tool’.

Stage 1- Initial Engagement

Paul Barber:

The researcher immerses his/herself in a deep personal questioning of what precisely he/she wishes to research, in order to discover and awaken an intense interest, relationship and passion in the research subject (p78).

Activities:

- * setting up a pilot cooperative inquiry group on stepfamilies
- * writing the first draft of my learning agreement which is not accepted;
- * abandoning this first course of action
- * identifying the research question
- * re-writing my learning agreement which is accepted.

Journal Entries:

Why Stepfamilies? Why this Subject at this time? The quick answer is that my family is a stepfamily and that seems important to me. My husband encouraged me to do this so possibly I’m doing this work for all of us. Within

that I think there is something I want to resolve. But also my family is divided and my son won't speak to me. I want to understand that.

I gather together a group of therapists and lay people to explore stepfamilies. I run two groups. On reading my notes I notice that my anxieties seem to relate entirely to stepfamily issues. My concerns are about how people who were in the first group will get on with people who are in the second one. I have written: "I am no longer focused on stepfamilies, I am more concerned about the group and how the new people will fit in". Reading this now I recognise how this echoes the concerns a mother might feel, introducing new stepfamily members to her children.

On being given the feedback that a focus on Stepfamily Dynamics is too broad, I have decided to focus on part of the whole picture by interviewing mothers like myself. In some ways I am disappointed by this limitation and in other ways excited. I feel partly like an adolescent who doesn't want restriction and who bristles at advice. However I have bitten the bullet and will start by thinking about myself as a mother. By choosing this focus I have put myself right in the middle of this investigation. It thereby becomes a self-investigation that extends from me to the wider world. It will answer a core query of whether I am alone in finding mothering in a stepfamily situation painful – (although being alone I realise is an existential condition of life; it cannot be cured and will probably be illuminated by the research). I wonder what I can learn through the experiences of other mothers who raised their children in stepfamilies? My question seems broad and phenomenological. In this project I want to try and capture experiences on paper and support empathy among humanistic psychotherapists. (I write this in my journal while I am on holiday in Alabama; my thoughts feel a bit sticky like the Alabama heat).

I am aware of potential conflict between my husband and my kids. If they are not getting on that is painful to me and I want to protect them both. At such times I feel pulled in different directions with none of me left whole in the middle. I wonder whether I am lovable and ask myself 'Is what's causing the

problem my parenting? Or my paranoia? Or his (my husband's) personality? Or something I cannot see? My husband seems to have the same feelings about his son in relation to me.

I am now thinking constantly about my own experience. I am also having dreams that relate to my own stepfamily experience; the split up with my husband. At the same time I am continuing to live in my own stepfamily, with its connections, divisions and satisfactions.

Comment:

At this stage I am beginning to do explorative activities connected with my future project.

I seem to be questioning why I am researching stepfamilies, as well as why I have decided to do a doctorate at all? Both have strongly subjective motivations and inform how I will proceed. It seems to me that my personal motivation for doing this doctorate is in part a way to connect with and be part of my birth family as well as an attempt to heal my current family. It took me a while to decide on the focus of mothers – an area less all encompassing than 'stepfamily dynamics'. In so doing I have brought the entire project closer to issues that touch my heart.

Stage 2 – Immersion

Paul Barber:

The researcher begins to live, sleep, dream and merge with the research question to the extent that he/she becomes it, so as to appreciate its intimate effects from the inside (p78).

Activities:

- * I am interviewed by Debbie
- * I interview other women, listening intently to their stories and becoming more involved in thinking about what they are telling me.
- * I transcribe several interviews and then delegate this work to other transcribers

- * I listen to recordings of the interviews and correct the transcripts;
- * I edit the transcripts to make first person transcripts – very absorbing work.
- * I run a workshop for the British Gestalt Society

Journal Entries:

I am dreaming about my ex-husband.

My thoughts are frequently turning to stepfamilies, I am discussing different aspects of this with everyone. I am continuing to deal with my own family; my son, my daughter, my stepson. I am interviewing people. I am also anxious and questioning my ability to do the work.

I have made a reciprocal relationship with my friend and colleague Debbie. She will interview me and be a ‘friend’ throughout the doctorate and I will supervise her. I am aware of a dynamic between doing what I want to do in the research i.e. follow my creative instincts, and justifying this with academic rigour. (The phrase itself freezes me). I fear that I will lose my creativity if I have to do this. As I write this I think of different parts of me that have different requirements rather like the different types of relationship that co-exist within stepfamilies.

I set up my first interview meeting and have the following dream the night before.

I had to play the flute in an exam. I was trying to play Bach and I couldn't even get the first note G. Eventually it was decided I should improvise. I was scared – I couldn't do that well, I have a limited repertoire; it wouldn't be as wonderful as they wanted, not up to standard. The music wasn't right and my flute kept coming apart.

I drive out of London for the interview with Sally. I am welcomed and impressed with her generosity: she makes me lunch. I transcribe the interview

and notice that intonation doesn't come through on the transcript that this can only be heard, and when it is, the meaning of the words change. I realise that it is important to listen to each recording in order to catch this.

I wonder about my questions, am I leading, listening, interpreting? What have I missed. I note that putting this all together at a later date will be very daunting.

In running a workshop for British Gestalt Society, a powerful conversation arises about mothers. In the evening I discuss attachment theory with my husband and a friend. I say that my problem with attachment theory is that it makes stepfamilies look dysfunctional whereas what they are is different. I prefer to think of stepfamilies constructively as a challenge for people to reach beyond their destructive inclinations and find the better part of themselves. While my interviews are with mothers, my overall interest continues to be the entire stepfamily.

I meet Amanda who wants to be interviewed. She is hoping in so doing to find some resolution with her daughter.

Michael Rosen talks about stepfamilies on the radio.

Comment:

At this stage I am immersed in activities and thoughts around stepfamilies, mothering and associated topics. I have begun interviewing and transcribing, I am talking to people and the whole project has become interwoven with the rest of my life.

Stage 3 – Incubation

Paul Barber:

The researcher allows the inner workings of intuition to clarify and extend his/her understanding of the question, while awaiting the tacit knowing that percolates to consciousness from a deep well of subconscious inner experience (p78).

Activities:

- * I intend to write but am frequently distracted
- * I re-read the interviews
- * I run a couple of workshops for stepfamily members
- * I talk to people in my walking group about my project
- * I wonder about how I will be able to pull it all together

Journal Entries:

Last night I dreamt about context, how everything happens within a context and that the context shapes what is seen in ever widening circles.

I am daunted at the moment by the idea of the ‘product’ that is required for this. I have some thoughts that I am beginning to put into action. Will they be enough?

I have an interview with my Academic Advisor. I want to see her to talk about how I am seeing things. I want to hear what she has to say. Last week I felt inspired, this week less so and unsure. I have lots of data and no idea how it fits together.

I have started an organisation StepIn ASAP – Advancing Stepfamily Awareness through Psychotherapy. Will this be acceptable as a product? What will I need to produce? Is it acceptable to present a patchwork doctorate with a mixture of methodologies? It is fine with me, but can I justify this? I have some confusion and some clarity and good techniques here.

I have the following Dream:

I am with my flute teacher Sarah in a very crowded music room. The other rooms are empty. Sarah wants a little girl to hear her mothers’ voice. The mother won’t ring her so the little girl rings her mother up but there is only an answerphone at the other end. The little girl speaks on the phone for a long time.

I am sitting in the Perls¹⁵ room in Metanoia Institute, my confidence is low. I realise that I am feeling angry, sad and alone. A memory comes to me as an image. I am climbing a mountain with my father. The peak is still a way ahead, although we have already travelled some distance. What faces me now seems tricky. I feel as if I can't do it. A voice inside tells me that I can and I must. As I say this my sense of sadness deepens, it's behind my eyes, in my face, down my back, I feel young and stupid. It's hard to believe that I can ever achieve reaching the top of this mountain of a research project.

Comment:

I think that I am like the little girl in my dream waiting to hear what a universal mother has to tell me through the voices of the project participants. I am also remembering that my father has died. I want his approval and he isn't here to see me. I feel like a child afraid to proceed wholeheartedly without someone to tell me what to do. I clearly don't trust my 'inner processes' to be working in the service of the research, behind the scenes.

Stage 4 – Illumination

Paul Barber:

The researcher reviews all of the data acquired from his/her experience and that of co-researchers, in order to identify tacit hidden meanings and an integrating framework that might be further tested and refined until it forms a comprehensive fit with experience (p78).

Activities:

- * I make a wall chart of participants;
- * I send bits of written material to supervisors;
- * I imagine this project to be like bits and pieces of clumped material that are slowly congealing to become solid;

¹⁵ Perls is a key (some say *the* key) figure in Gestalt and Metanoia Institute has a room named after him.

- * I start an organisation to bring this work into the professional field;
- * I write, write, write.....

Journal Entries:

I am becoming increasingly aware of stepfamily situations in everyday life. I overhear this conversation between two women in the gym:

“what’s the wedding?”

“it’s my husband’s daughter. We’ve been together twelve years and she wouldn’t invite my children to the wedding”.

“They’re like stepsisters aren’t they?”

“yes, but it’s about numbers. Furthermore she said ‘I hope people don’t think Joan is my mother’”

“My father’s going to have his ninetieth birthday party. I can’t even tell my mother. They’ve been separated for forty years and won’t talk to each other. They live in the same small village and cross the road if they see each other. They were married for twenty eight years. They should never have had children. I can hear my mother now ‘he was never much of a father to you’. He should have stayed single really. They are the only separated couple I know who didn’t find other partners. They’re both too bitter”.

Stepfamily situations seem to be everywhere! Does this belong to immersion, or illumination, or are these stages all happening at the same time? I certainly feel on a rollercoaster. Nothing is clear.

I am writing, but feel as if I’m writing for a panel of severe academics, who will call me to account for every word, thought and nuance. I am so bothered by the idea of this impending judgement, that each word feels squeezed out of me. I spend hours putting down a word, crossing it out and restarting, then getting distracted by an email. I am suffering from the writers curse, and what

is actually coming out seems rather dead. In desperation I start to read more. I come across Women's Ways of Knowing. Illumination strikes me. I am so relieved. Of course, I am thinking like a woman; I have been desperately trying not to be myself, to impress an imaginary someone who appears to be a rather strict version of my father. I've also been trying to fit everything into a Gestalt framework and it hasn't been working; it's too complicated.

Everything is falling into place.

But even with this realisation, I still have to write and bring things together. I go over the data again and again, reading, writing, analysing. I continue to be bombarded with thoughts and ideas about mothers and stepfamily situations. I feel inadequate; I should find a focus, but do I have a focus? What was my original question?

Now I start to put the material together in different ways. I have made a big chart of all the participants and put it up on my wall. I return to the interviews and once again work on trying to feel the essence of each woman I have interviewed and writing it up. I stop waiting for some magical focus to emerge, and decide to put down themes that make sense to me. I feel that I know something about each of these women well. I also have an increased sense of myself as mother. I am beginning to be aware of mothers and mothering in my therapy work.

Comment:

Illumination seems to be arriving in bits. Snippets of revelation come to me. The work is now beginning to coalesce, although it is still hampered by my fear of inadequacy. I see through my writing that the experience of mothering is becoming a stronger focus than that of stepfamilies.

Stage 5 – Explication

Paul Barber:

The researcher attempts to examine fully what has awakened in consciousness, in an attempt to familiarise him/herself with the layers of meaning that

surround the phenomenon being studied, inclusive of its universal qualities and deeper meanings so as to create an appreciation of its phenomenological whole (p78).

Activities:

- * I review the interviews with interpretations; give these to colleagues to read and ask for comments
- * I discuss mothers and stepfamilies with colleagues, my husband, anybody who is interested;
- * I get feedback on what I have written
- * I set a deadline for completing a second draft

Journal Entries:

My journal entries have changed. I am no longer writing in them about process but have lots of lists. I send what I have written to my Academic Advisor and External Consultant and when I get the feedback feel devastated, and it takes time to get back to serious writing. I have started reading more – against all advice – but then I wasn't reading before. Now I pick up books on narrative research, on mothering, on stepfamilies. I start to think more seriously about the structure of my writing. I decide that I will write up my findings over the summer. I devise a structure for this, but as I write it expands; this in itself would be a book. When I send it off for comments I receive back how confusing this is. Once again I am in despair; can I do this? Will I be able to do this? Do I want to do this? Do I feel as if I have any choice? I feel very upset each time I think about this. I am afraid of failure.

Comment:

This seems to be more confusion than illumination. While the heuristic process sounds useful, at this point it seems that I have become stuck and the map no longer seems to hold. There is an element that has floored me all the way, which is that while part of me wants to do this work, another part feels that I can't and is frightened of being humiliated by failure. This is much more of an emotional process than I ever envisaged, and hard work.

Stage 6 – Creative Synthesis

Paul Barber:

The researcher forms a creative synthesis of the research theme with a view to appreciating the real significance of what people actually experience (p78).

Activities:

- * I write every morning, every spare minute and over Christmas taking time off work to write;
- * I take on a structure that works;
- * I see my findings reflected in others' writing;
- * I find an image that encapsulates what I feel is the essence of what it means to be a mother.

Comment:

Now my journal has entirely changed. It contains pictures, snippets of conversation, provisional structures and book titles. I have stopped writing about process altogether it has instead become the process. Well not entirely: one page reads 'I want clarity that what I've done is OK'. I feel swamped. What is good about what I've done? I want a way forward, I feel lost. Can you help me work this out?' I remember feeling angry and that I hadn't had enough contact with my supervisor contact.

I have been seeing a therapist throughout this project. He is starting to tell me of his own stepfamily stories. I feel touched and wonder if he will help me out. I now return to meetings I had with my external consultant at an earlier stage, and accept his suggested structure. It makes sense; I feel safe within it and feel it is something I can do. One of my journal pages is a mind map of a chapter on mothering.

I now realise that all the writing and thinking that I have done, discarded and started again can indeed be pulled together. Something I didn't envisage is that

the outcome continues to be an amalgam of different themes which suggest possible further explorations. I realise that the nature of how I have approached this project would never have given a focus of the type I thought I should have when I started, because I wasn't trying to focus in such a way, I was trying to capture experience.

One day, while at supervision talking about something entirely else, an image comes to me which seems to illustrate exactly what I have been trying to get at. It is of a woman, she is being pulled in two different directions. She is split in half exactly down the middle: her heart is broken in two. But through the split there is light and space shining through. This is how I see the mother in a stepfamily. This was inspired by a quote from Leonard Cohen's song 'Anthem':

*Ring the bells that still can ring
Forget your perfect offering
There's a crack in everything
That's how the light gets in.
(1992)*

Comment:

At this stage, the confusion, the various thoughts, bits of writing and transcript, come together in the writing. I have more of an understanding of what the task involves. I increasingly see that this is my project, that my job is to describe it and to recognise my process, to think about what I have done and ultimately to comment on it critically – as I do in the final chapter.

The above writing has been edited for readability, but is deliberately experience close. Most of it is based on what is in my journal. It shows that a heuristic approach could be seen as a model for the process of learning and illumination, more than a method. Or that the method is indeed the person of the researcher.

Summary

In this chapter I have described how my work as a Gestalt practitioner influenced

how I conducted the entire project, however a more fundamental influence has been my identity as a woman and mother. I have referred to the ideas in ‘Women’s Ways of Knowing’ (Belenky, Clinchy et al., 1986) which were crucial in recognising the ways that I know what I know as a ‘connected knower’. The concept of connected knowing has equivalence within Gestalt field theory. In a similar way, all the methodologies that I have drawn from complement Gestalt and could be seen as an extension of a Gestalt model.

For this investigation I used a fluid organic process and mixed methodology. It is predominantly phenomenological, in that it seeks to explore human experience, both my own and that of other mothers. While I have listed methodologies sequentially, the process of carrying out this project involved several activities taking place over a period of time.

The data has been explored in a number of ways and I have been the primary tool of the research. Bringing together the many threads of the data and other activities into an integrated project has taken place through a heuristic process of immersion, incubation and illumination – not experienced in any particular order. This is illustrated in the last section through extracts from my journal, juxtaposed with Paul Barber’s list of heuristic stages.

The next chapter details how I conducted the project, and includes a final section on ethical considerations.

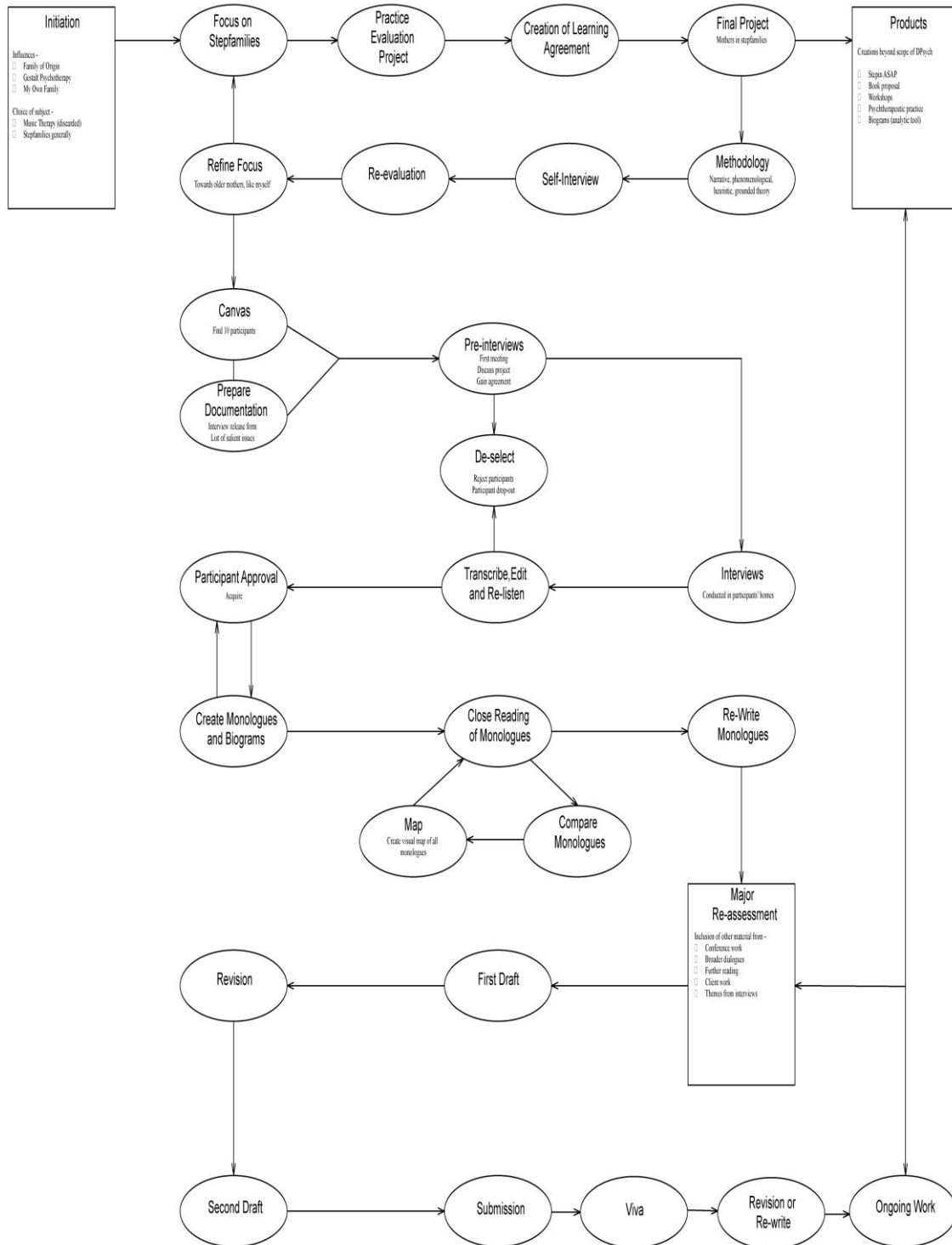

Figure 1- Flow Chart of Entire Project

CHAPTER 4 – PROJECT ACTIVITIES AND PRACTICES

The activities that constituted this project which have involved me as researcher, writer, participant and actor in the wider world, are presented in this chapter. As Behar says I have been intertwined with the process in a deeply problematic way (Behar, 1996; quoted in Etherington, 2004, p55), or put simply I have found it both absorbing, and challenging.

The entire activities of this project are presented in the flow chart on page 63. This maps the progress of this project, starting on the top line with prior related activities and influences leading up to the Learning Agreement and its implementation in an evolving design.

Activities took place in three main areas:

- a) An exploration of the narratives of eleven mothers who raised their children in stepfamily situations.
- b) The development of psychotherapy work with people in stepfamily situations.
- c) The founding of the organisation StepIn ASAP – Advancing Stepfamily Awareness through Psychotherapy (see ‘Products’ on Flow chart page 63).

Additionally this project involved a journey of self-discovery and recognition which took place alongside research and practical exploration and which is described further in the final chapter.

The whole project stretches back into the past as it is a continuation of my earlier work and interest in stepfamily situations and into the future as the exploration, building of knowledge and development of work with people in Stepfamily situations continues.

Criteria for Participation

As shown in the second line of the flow chart on page 63 I canvassed for participants following my own interview. As described in the next section, during the course of being interviewed myself I realised that the passing of time has meant that situations which had felt unyielding at the time had since moved on. Life is more stable now than it was when my children were living at home. It seemed that a retrospective reflection was useful in making sense of those experiences as I now able to look at them with some distance and with the advantage of being older and more mature. Because of these factors I decided to look for participants who were like me in these respects. In other words I looked for women who were mothers, who had raised their children in a stepfamily situation, who were aged forty years upwards and whose children had left home or were in their late adolescence.

I thought that such women would be able to reflect on events as I had done. They were unlikely to be immersed as intensely in their family situations as they might have been when their children were young, and the passing of time would mean their situations had changed. Additionally I thought that they were likely to give fuller accounts of past events than of those that were still taking place and therefore unresolved.

To find participants I contacted everybody that I thought might be able to help from my mailing list, work colleagues, conference delegates, staff at Parentline Plus and people who had taken part in earlier exploratory groups. From this I found eleven women, some of whom I knew. Three were friends of a friend, one was the friend of a woman I walk with in the morning and she put me in touch with the partner of her ex-husband; one was referred from Parentline Plus, another by my supervisor, one was a work colleague, one the sister of a friend and one a woman I met at a conference. Another woman who later dropped out had been involved in an earlier inquiry group connected with my Practice Evaluation Project.

The following list describes this group.

- * All the participants were over 40 years old, white and heterosexual,
- * Professions of participants included, counsellor/advocate, probation officer, mental health worker, artist, potter, academic and psychotherapists (one of them me). They could all be labelled as middle class – or living what used to be called an “alternative life style”.
- * Four had followed a similar course to me in their lives; they had been ‘hippies’ interested in an alternative society. These four lived in the same rural area of England and had been or still were involved with a meditation teacher that I spent many years being involved with.
- * Two were nationals of other countries, three were children of immigrant parents, one came from Wales, another from Ireland, two were Jewish and the other three English.
- * All the women but one had separated from the father of their children. One lived with her partner who had children from his previous relationship with one child between them.
- * Nine lived in stepfather households, or had done so for a significant period of their children’s lives.
- * One did not consider herself to be in a stepfamily until I approached her. She had been joined by her partner when she was pregnant with another partner’s child and he became a ‘psychological father’ (Robinson and Smith, 1993, p18).
- * One was a single mother whose ex-husband had remarried.

I had different levels of familiarity with the participants. One I work with and know well; another is the sister of a friend, another is an acquaintance whom I had met briefly, one other had been a previous work colleague and another had been a member of the pilot inquiry group that took place before I decided to focus on

mothers (see transcript on page 407). The others were people that I had not met before.

A chart of participants can be found on page 133.

Interviews

The transcripts of interviews provided the primary data of this investigation. Starting with being interviewed myself I used information from that experience to re-evaluate and refine the focus of the project and then canvassed for participants as described above. I conducted eleven interviews and met with each participant twice, the first meeting was a 'pre-interview' meeting that laid the ground for the interview meeting and the participant's overall involvement in the project. The following sections describe this in procedural order, starting with my overall approach to interviewing as represented on the second and third lines of the flow chart on page 63.

Approach and Design

Approaching the interviews with traditions rooted in Gestalt therapy, phenomenology and narrative I incorporated principles of authenticity, co-creation and non-directionality. I viewed the interviews as dialogue; an exploration of the participant's experience and the field that they were part of, facilitated, rather than led, by me. I wanted the women I interviewed to be free to talk about what was important for them and for me to be free as interviewer to follow my interest as they talked. It seemed to me that were I to set many – or any - questions this would guide participants strongly towards what I wanted to find out and marginalise what was important for them and I recognised that I had the potential to influence data by overly leading the interviews. Instead I wanted the area of conversation to be a co-creation.

The design was a form of phenomenological interviewing (Moustakas, 1994, p114) in which I followed the injunction to be creative, and to adapt myself to the situations I faced (Fontana and Frey, 2000; quoted in Etherington, 2004, p77). I started each

interview by asking who was in the participants' family. I hoped that the process of describing this would naturally lead into stories of mothering with direction and focus arising in the conversation between us. I intended to transfer techniques and skills from psychotherapy to develop an atmosphere within which participants would offer deep, honest and revealing narratives. I ended each interview by asking how the participant how she had found it to be interviewed.

I realised that despite the minimal structure of the interviews it was inevitable that I would unwittingly influence their content to some extent through my body language or in other ways. For example my eyes might brighten if a thread excited me, if my interest increased I might lean forward or I would question one aspect of what a participant said and not another. However were I to hide my responses then I would stifle my contribution to the interview process and betray my intention to be transparently present. It therefore seemed more important to be authentic in the interviews, occasionally sharing experiences and asking questions when I was genuinely curious and wanted to know more.

Self Interview

My first step was to test this form of interviewing and contribute my own material to the data through being interviewed myself. I asked a colleague and friend – Debbie Friedman - to interview me with the instruction that she do so without a prepared list of questions and to follow her curiosity as it arose in connection with what I had to say. I chose Debbie to do this because I trusted her to treat what I had to say with respect, to ask useful questions and not to avoid difficult areas. I had confidence that she would listen well and be able to follow my narrative as I intended to do with others. The interview with Debbie lasted one and a half hours before the dialogue came to a natural end.

I found being interviewed a powerful experience in which I put my story together in a new way and covered lifelong themes that up till then I had not identified. The most striking personal discovery through this interview was realising that I had a strong drive to fulfil myself as an individual which conflicted with the demands of

motherhood. This led me to hypothesise that other mothers were likely to be managing a similar dynamic; a theme that I would be aware of when analysing data.

Although an aim of this interview was to test out the efficacy of my intended interview method, there were factors that made this interview different from the others I intended to carry out. As a participant being interviewed by Debbie, I was on familiar ground, working with someone I trusted, who has known me for many years and has witnessed those events in my life that were the subject of the interview. In contrast most of the people I intended to interview would not have known me beforehand. For these participants I would have to develop a relationship and build trust at the interview. Additionally both Debbie and I are psychotherapists. The nature of our work has involved us in self-exploration, talking in depth and facing difficult events and feelings of our own in our own therapy and training groups. Even though we both work in this field it is still not easy or comfortable to talk about events that evoke such feelings. I surmised that with other participants it would possibly be the first time they had taken part in the type of conversation I hoped to carry out. They might therefore find it more challenging than I had.

Overall being interviewed myself served several purposes. It gave me firsthand experience of being an interviewee; it enabled me to assess whether my proposed techniques would produce the fluid narrative that I anticipated, which it seemed that they would; I obtained my first narrative and was rewarded with insight into my own mothering experience. Furthermore I refined my criteria for participation, which I describe in the following section.

Pre-Interviews

I had several documents and points to discuss with participants in relation to the project (see Appendix II pages 421 - 424). Therefore I followed the protocol suggested by Moustakas (1994, p177) and arranged pre-interview meetings with all participants. These meetings served several purposes: they were a first meeting between us and the beginning of establishing a rapport; they enabled me to discuss the project with people before they committed themselves to participating; I was able to introduce the project, how I was approaching it, the area of interest, highlight

potential difficulties and discuss ethical issues; I was able to offer support and obtain consent. The pre-interviews also provided an opportunity for participants to withdraw, or for me to decide not to work with them.

These meetings took place one or two weeks prior to the main interview whenever possible, however there were several that were only a day or two apart. In each case the participant chose where they took place. The purpose of this was for it to be somewhere convenient for them and on their territory. I entered their world rather than asking them to enter mine. One took place in the British Library, one in a pub, two in a coffee bar over lunch and the rest took place in people's homes. For two of these meetings I travelled out of London.

The pre-interviews were not recorded as at this stage the participant did not have a contract with each other and I felt that being recorded could be inhibiting. Recording was not relevant for these meetings as their primary purpose was for me to brief participants on the interviews and issues that might arise; the secondary purpose was for us to begin to know each other and to establish a relationship.

All the pre-interview meetings had the same format. There was a formal aspect which was the same for each participant and an informal aspect that differed with each person.

The formal aspect included:

- * My appreciation for their offer of participation
- * Discussion about to the potential for an interview to be distressing
- * A description of the focus of the interview and how it would be conducted
- * A discussion on issues of confidentiality, anonymity and potential implications for participants
- * Consideration of the implications for other family members
- * The offer of a confidential meeting to discuss the experience of being interviewed and ensuring that participants had adequate support structures

- * Giving of documents – consent forms, letter outlining project aims and issues covered in the meeting.

The less formal aspects included conversations about the research project, our families, stepfamilies and subjects of mutual interest. This was a space for the participant and I to find out a bit more about each other before the interview itself; where I could establish my intention to be open about my own experiences as a mother in a stepfamily.

In this first face to face contact as researcher and potential co-researcher we were able to perform a preliminary assessment of each other. This is an activity which Phillipson describes as taking place, often beneath the surface of interactions when people meet who have not known each other beforehand (2001, pp55-62)¹⁶. These pre-interview meetings enabled this to happen prior to the main interview and for the participant and myself to develop rapport and ease with each other, to some extent.

I felt it was equally important for me to meet people that I already knew in this way as it was for those I didn't know. In these cases the pre-interview meetings allowed them to meet me in the role of researcher and for me to experience relating from a facet of myself that I had not previously shared with them.

A further reason for meeting before the interview was to ensure that the potential participant fitted the criteria for the study and that we both felt we could work together on this. Because of the dialogic character of the research I was carrying out, it would have been difficult and perhaps impossible to carry out a useful interview, if on meeting, a potential participant took a strong dislike to me or vice versa, or we found ourselves disagreeing about the parameters of our work together.

Main Interviews

It was important that as far as possible participants felt comfortable, not intimidated by me and their surroundings. I felt this was more likely if they were interviewed in

¹⁶ Phillipson describes these tasks in regards to a first meeting with a psychotherapy client. These include initial meeting, dealing with expectations, negotiating the parameters of the relationship.

a place where they felt familiar and in control; in their own domain. Therefore I asked to interview each participant in their home, which meant travelling some distance for several of them. By letting me into their homes, participants let me in to their territory and thereby were showing me an aspect of themselves. I saw this as a step towards allowing me to enter further into their world, their family's history, and their connected emotions and thoughts.

Being in participant's homes contributed to my sense of that person; for a short while I was part of their life. In every instance we engaged in informal conversations before and after the interviews. I was offered cups of tea, met members of some participants' families, sat round a table talking with them and their friends and in two instances was given lunch.

Each interview was recorded for later transcription. I proceeded by setting up the recorder and then asking 'tell me about your experience as a mother in a stepfamily' and 'who is in your family?' Other than that the interviews were without questions until the end, when I asked how they had found the experience of being interviewed. Thus I worked with a focus rather than a set agenda. The requirement for me as interviewer was to hold back, keep the focus on the participant with the aim of listening carefully and intently. Questions in the main prompted the participant to clarify or explain something more fully so that there was space to allow what was important for her to come forward. The idea was that a focus would emerge both in the interviews and later in the course of data analysis. I talked about myself occasionally but held in mind that the interview was not intended to be an opportunity for me to tell the participant about myself or to have a friendly chat.

The interviews were not therapy sessions and they were not conducted as such, however I transferred methods and skills from my work as a psychotherapist to my interview technique. These methods help me elicit deep personal narratives from clients and I felt that they would equally support the development of depth in these interviews. I now summarise important aspects of how I conducted myself as interviewer:

- * Showing a clear and intense interest in the participant through looking at them, asking questions for clarification
- * Feeding back what was said – sometimes in my own words
- * Thinking about the essence of what I was hearing and inquiring about that
- * Allowing silence to take place between us when conversation had stopped. (I found this often preceded new material).
- * Using my intuition and feelings to guide my curiosity. For example, if I felt tearful when someone was talking I'd enquire about their tearfulness.
- * Sharing personal information if I felt it contributed to what was being talked about, taking care to keep the focus on the participant.
- * Asking questions out of curiosity
- * Throughout, checking myself, what I was feeling, where I thought the participant was going, where the focus was.

I found that knowing the people I interviewed did not ensure that the interview would be easy. With Amanda who is a work colleague, our conversation I felt at comfortable and our conversation became fluid and deep with thought provoking content; however with Mary who is the sister of a friend, I felt stilted as an interviewer and shy. The contrast between these two might be explained by the forums we know each other in. Amanda and I work together as psychotherapists and the interview with her felt like an extension of how we are used to relating together. However my contact with Mary the sister of a friend has been mainly social; at parties or meals. Interviewing her involved showing an aspect of myself that that she had not previously seen and learning new things from her that she had not previously told me. I felt embarrassed to be seen as thinking, serious or enquiring; it showed me that in some settings I underplay this facet of myself. We were not accustomed to being open with each other in this way. Thus knowing participants in another setting

had the potential to be an advantage or a disadvantage depending on the nature of our relationship.

Differently from how I conduct myself when working as a therapist I frequently shared my own experiences at times, ‘chatted’ and discussed issues. My willingness to talk about myself at certain times occasionally brought about situations where the roles between me and my co-researcher reversed and either I was talking and she was questioning me, or we were sparking thoughts off each other, so that one followed the other. At such times the interviews became a more equal dialogue, conventional roles disappeared and there was a dialogic flow that led both of us into deeper conversation.

Exploring the Data

Through the above methods I obtained twelve recorded interviews (including my own) ranging from forty minutes to three hours. My primary data consisted of the transcripts of these interviews (see Appendix VI) .

The processes of working with this data immersed me in the participant’s stories of mothering in a stepfamily and sensitised me to my sense of myself as a mother, and my awareness of mothering and stepfamily issues in others. The work progressed in stages which I allowed to evolve fluidly and which involved and re-involved me in the data. These stages are listed on the flow chart (on page 63) as Transcribe, Edit and Re-listen, Participant Approval, Create Monologues and Biograms, Close Reading of Monologues and Re-Write Monologues. I now describe each of these in turn.

Stage 1 – Transcription

The first step was to transcribe the interviews. Etherington strongly encourages that the researcher carry out their own transcription (Etherington, 2000, p293). She notes that despite this being difficult and time consuming, it enables the researcher to become closely engaged with the material; to catch nuances, hesitations and to hear what might have been missed. For these reasons my original intention was to do my

own transcriptions and I did this for my own, Clody's and Maria's. However transcribing took a lot of time that I felt would be better served in other ways. I therefore decided to pay someone to do the remainder of this work and for me to engage with the transcripts by listening carefully to the recordings. Other than the three I transcribed, Madeline the daughter of a friend transcribed four and the rest were transcribed by a professional service. I was able to ask Madeline for feedback about the interview content and its impact on her. This also served as a de-briefing.

Stage 2 – Re-listening and Editing

As I had not transcribed most of the interviews I missed engaging with their content in the deep manner that transcription allows. I was in a sense disconnected and needing to find a way in. The practical demands of the situation provided the solution to this, as it was clear that the transcripts were textually faulty and I had to listen to each one in order to correct them along with the transcript. This activity became the first step in re-engaging with the interview content, noting turn of phrase, hesitations and so forth. I found through doing this that I remembered again the people I had worked with. Hearing the inflections in their voices added a dimension to the written words.

After re-listening I corrected each transcript and sent them to the participant for approval of their accuracy and agreement that I might continue working with them. The accompanying letter is included on page 424.

At this stage one participant did not return her transcript. I phoned her to find out what was happening and she seemed short on the phone, saying that she would contact me later. I did not hear back from her and therefore did not include her interview in the data. This I found quite disturbing as I was left guessing as to whether she was irritated with me or whether there was a personal reason for her to deselect herself. I had hoped if there was any discomfort around the research process that participants would discuss that with me. This therefore feels unfinished in the overall project.

Stage 3 – Creating Monologues

The third stage of working with the data was a procedure that I arrived at accidentally after transcribing the first interview, which was Clody's.

I saw that Clody's narrative was out of order as regards time, but that the different sections if moved around contained her story from when she was a child to the time of interview. I therefore experimented with putting her words together in a sequential order to create a first person narrative uninterrupted by my questions. Thus I took out my questions and interventions and moved her text around putting similar themes together and editing it for fluid reading, occasionally I added words but this was rarely necessary. The practical outcome was a narrative; the story of Clody's life as a mother who both grew up in and later raised her children in a stepfamily situation.

The process of editing was engrossing. I found that I became enveloped in thoughts and feelings about Clody. I had a sense of the events and issues that influenced her, her style of mothering, her issues with stepfamilies and the things that were important to her. Thus through this process I felt that I had become personally involved with Clody's story and had connected with and immersed myself in the interview material. Because this seemed to be a useful way of engaging with the data, I followed the process for each interview, including my own. Eventually I had eleven narrative stories. In creating each of these stories I became enveloped in the material as I had done with Clody's. These are included as narrative monologues in Appendix I page 256.

In the same way as I had done with the transcripts, I sent these narratives back to the participants for comment. I heard back from all participants except for Maria and Barbara. I decided at this stage to continue with all participants' material, as agreement to accuracy had already been reached through approval of the transcripts.

Stage 4 - Creating Genograms and Biograms

Genograms are a system developed in the 1970s by Dr. Murray Bowen, a significant figure in the family systems model. They are a variation on the family tree and are 'widely used by family therapists to clarify patterns of events and relationships

within and across generations' (Friedman and Karakauer, 1992). By presenting families in a visual form Genograms can illuminate relational dynamics. I created Genograms of each participant's families. This enabled me to have a visual representation of each family's structure and how the participant placed themselves within it.

An example of a simple genogram is given in Figure 2 - Elaine's family Genogram. It shows Elaine's family (surrounded by dotted lines) as a cluster within a larger family. Elaine, who was the participant, is identified by a double boundary. This Genogram shows Elaine, her partner and her son as a unit and John connected to another woman – his ex-wife with whom he has two sons.

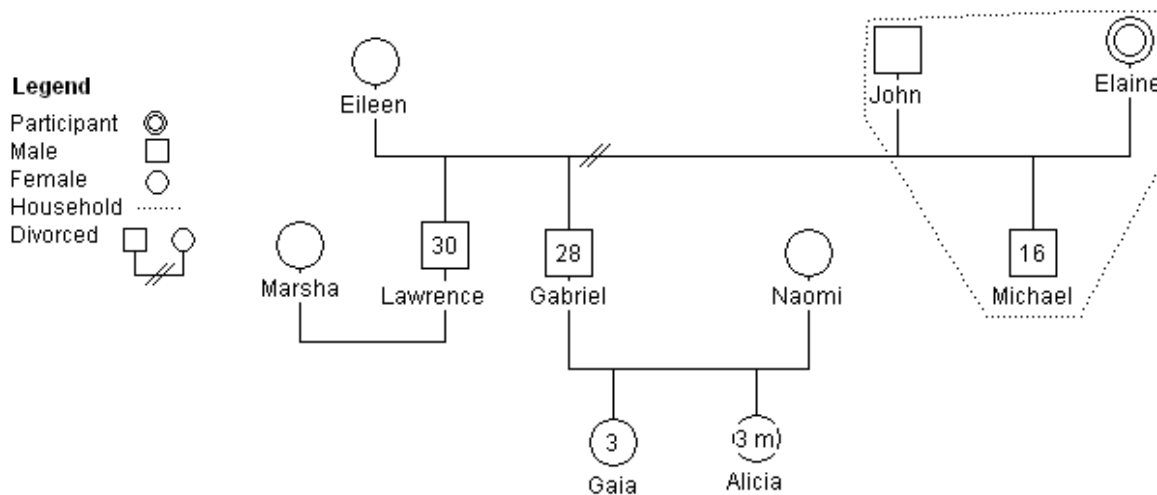

Figure 2 - Elaine's family Genogram

In my earlier research on couples in stepfamilies (Salisbury, 2004) I found that there was a difference between how people felt towards their biological children and their stepchildren. Therefore I experimented with mapping family relationships with an emphasis on blood lines rather than marriage/partnership lines. I called these drawings Biograms. The Biogram in Figure 3 shows Elaine's family connected by bloodlines. Her current relationship is indicated by a dotted line. Biograms are

presented fully in Chapter 6. Genograms and Biograms of all participants are included in Appendix I on page 248.

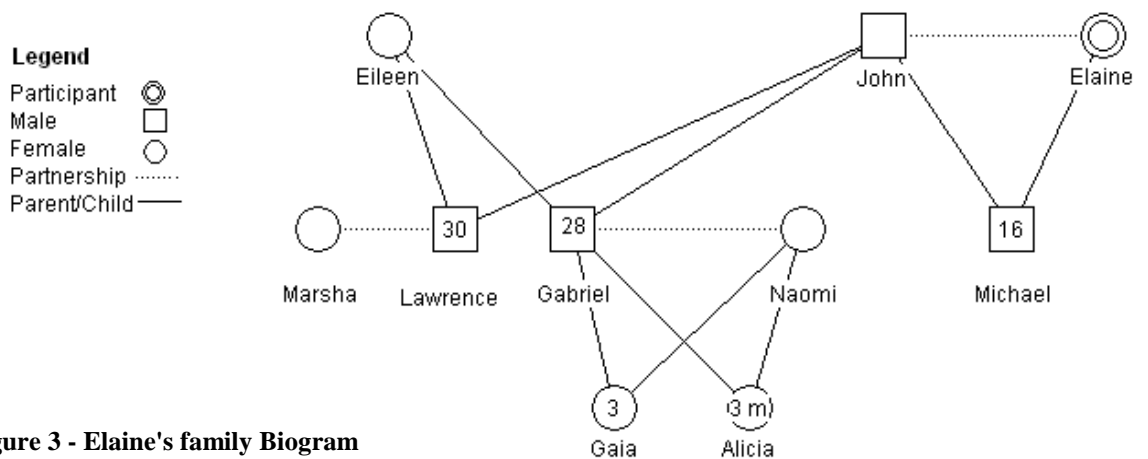

Figure 3 - Elaine's family Biogram

Stage 5 – Comparing Monologues and Developing Themes

Making first person narrative stories and working with Genograms and Biograms had the effect of involving me in a meditation on each participant. However because I was becoming focused on the individuals separately I found that I had very little a sense of them as a group and felt that I did not have a focus. The question I asked myself at this stage was ‘what does this project need from me?’ and the answer seemed to be that I must step back and look more objectively.

Influenced by grounded theory I sought to make comparisons between the participants. I stuck together several sheets of paper to make a huge sheet that filled my dining table. Going through each interview in turn, I made a row for each participant and columns with themes. The outcome was a patchwork chart filled in with excerpts from the interviews or my thoughts in tiny writing (see photograph on page 80). I put this above my desk where I was able to refer to it when I wished and it became something that I lived with.

As I put the chart together I found myself imagining conversations between the participants. I identified with some participants more than others. I also imagined relationships between them; for example I felt that Elaine would have disapproved of

Amanda for not putting her children first, however I also felt that I understood the influences that were motivating Amanda. I was able to see the women as types of mother who had differing styles of family. It was from this process that I developed the thematic findings in Chapter 5.

Stage 6 – Analysis and Interpretation

The final stage of working with the individual narratives was to return to the interviews and read closely what was being said in order to get a sense of the subtext. For this stage I worked to get behind the words and brought my mind to bear on each woman as I might a psychotherapy client, making connections through identification, empathy and psychotherapeutic theory. Thus I used both my own experience and information that I had gleaned from different psychotherapeutic writings. In doing so I attempted to get the sense of a core theme or issue for each participant. In Barber's list of heuristic processes, this might be described as *illumination* 'where the data is reviewed in order to identify tacit hidden meanings and an integrating framework' (Barber, 2006, p78). Again this was a fairly lengthy process the outcome of which was a further rewriting of the interviews with sections of transcript interspersed with my own commentary. Examples of these are given in Appendix I pages 392 - 404.

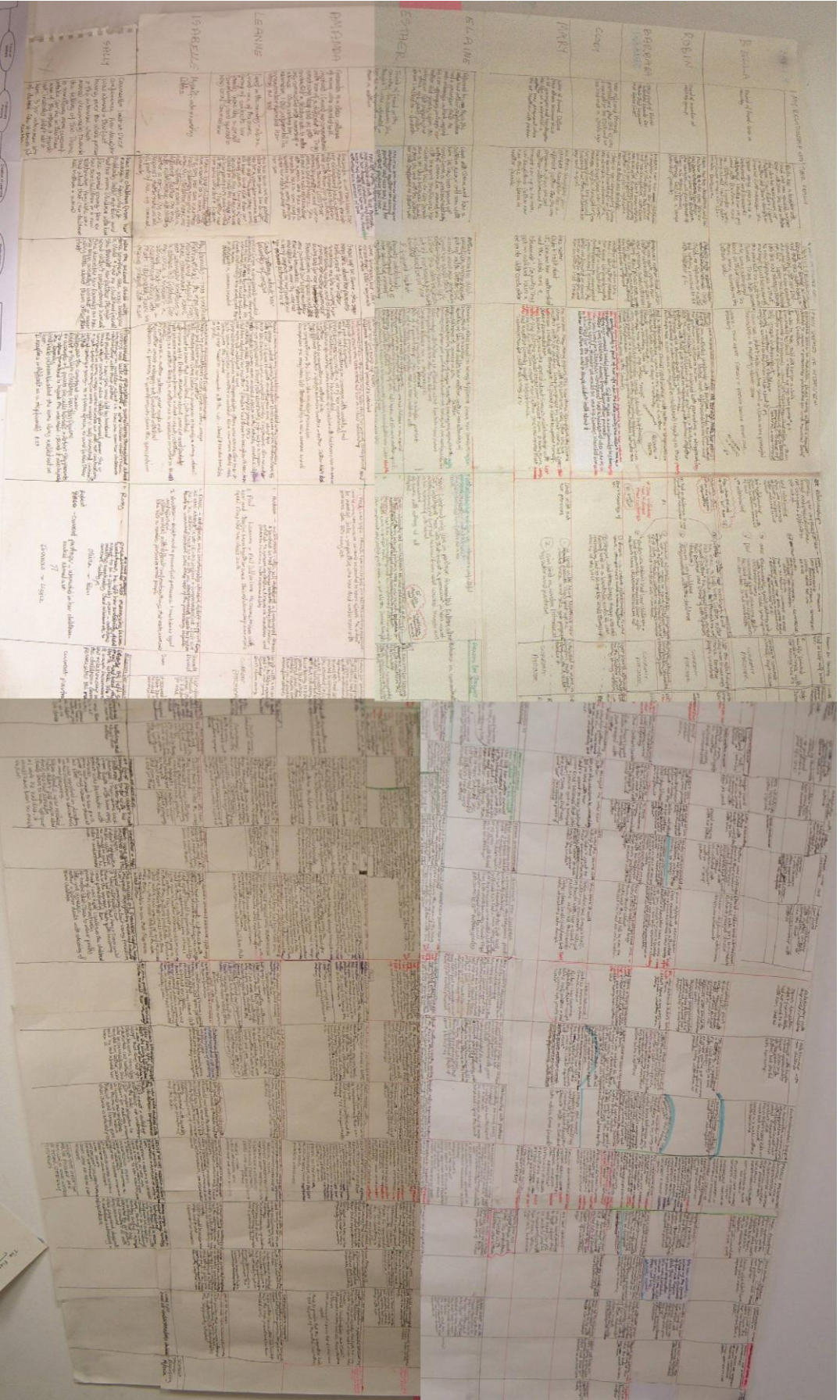

Figure 4 - Photo of chart over my desk

External Influences

While I was engaged in the heuristic research process and working on the data, I found that in the course of my everyday life I was noticing stepfamily situations, discussing stepfamily issues with strangers and friends. I found myself often involved in informal conversations about stepfamilies which occurred serendipitously in the course of my everyday life. Here are two examples of this:

Incident a)

In a hospital while waiting for my daughter's baby to be born I struck up a conversation with the elder of two young girls one about eight years old and the other six.

Me: Are you waiting for your mother?

Girl No she's my stepmother.

Me: Oh that's interesting, look at what I'm reading.

I Show her my book 'Growing Up in Stepfamilies' (Gorell Barnes, Thompson et al., 1998)]

Girl My mother had a boyfriend with four boys.

Me: What was that like?

Girl I didn't like it much. The oldest one liked football (grimace) and the middle ones were strange. The youngest was quite cute.

The youngest girl nods and smiles as she speaks.

Girl My mother finished with him though. She thought the boys were too much and he was always phoning their mother and making arrangements and all that.

Incident b)

At our local quiz night the woman sitting next to me on hearing about my research tells me the following story:

"I had a stepmother who was an archetypal bad stepmother. My mother died when I was eight and she was taken away in an ambulance by a nurse. Nobody talked to me about this. The next

thing I knew she was being introduced to me as my father's future wife".

She then introduces me to another woman who says

*"the things I could tell you about stepfamilies!"
although she doesn't furnish any further details.*

Thus while I have been working on this project, thoughts about stepfamilies and situations concerning them have been arising in every area of my life; my home, my work and my social life.

Summary

In this section I have described the research activities of this project; the interviewing of twelve women and exploring the transcripts with a variety of qualitative methods. I now turn to ethical issues that arose during the course of the project.

Ethical Considerations

.....An ethical attitude grows from within, in relationship to one another, just as a mother begins to relate to her infant as she feels the first fluttering and stirrings of new life growing within her, and this sense of relatedness continues to grow in pregnancy. From birth there is the beginning of the actual relationship between mother and baby, a reverie and closeness that is unique and special. No amount of reading the rules of parenthood can prepare a mother for the unique inner relationship that she and the baby will experience with each other, and in the same way no amount of reading and learning the rules of analysis can prepare the analyst for the unique relationship they will experience with a patient. (Richardson, 2003)¹⁷

¹⁷ Given as part of a discussion document by Tim Bond, at his specialist seminar titled 'Prioritising People or Knowledge? Tensions between Research and Professional Ethics'. See Appendix III p434' See Appendix III p437'

The above extract which compares a relationship between analyst and patient to that of mother and child contains the point that I would like to carry over into this section on ethics. That is of an ethical attitude being an aspect of relating; a way of being and feeling within a relationship irrespective of guidelines.

I, as do many others, strive to be an ethical human being, to be responsible within all my relationships, to both look after my own needs and recognise and respect others. This is not always as straightforward as I would wish. Conflicting perspectives, wants and needs, misunderstandings, angry and hurt feelings can be challenging to this attitude. Nevertheless maintaining an ethical attitude and a felt sense of ethical propriety is intrinsic to my work as a therapist and embedded in my private life.

As a psychotherapist, in addition to maintaining an ethical attitude, I have needed to be aware of and adhere to the ethical principles provided by my registering organisation UKCP (United Kingdom Council of Psychotherapy). These offer a framework for therapists' relationships with clients. However ethical practice in my view needs also to be intrinsic to the person of the psychotherapist, to be felt and understood in relation to their client. In the same way a researcher needs to both follow guidelines and hold an overall ethical stance in relation to her participants.

Being an ethical researcher involved following guidelines and also more importantly recognising that some ethical dilemmas could not be neatly resolved. These were such things as questions about authorship, ownership and dual relationships, the inclusion in narratives of people who had not consented to be in this study e.g. ex-partners and children, the dynamic between trusting participants' autonomy and informed consent, and my fear that they might not have recognised the potential implications of their involvement.

Ethical issues in Role of Researcher and Psychotherapist

The way that I managed my relationship with participants in this project had some similarities to my relationship with clients in psychotherapy but there were some important differences. The most apparent is the framing of the relationship; I did not have an ongoing weekly meeting with participants. Neither were the participants people who had approached me to support them in finding a way through difficulties,

or in their self-development. However I understood that I had a responsibility to be aware of issues that might affect them in our work together. As Etherington says:

....as researchers we need to take responsibility for the skills and knowledge we hold as therapists: if we stumble carelessly into intimate personal research relationships we take the risk of leaving participants worse off by our encounters with them' (Etherington, 2000, p227).

Writing about ethics in a counselling situation, Tim Bond¹⁸ notes that guidelines have been set to prevent the exploitation of clients and to preserve their safety 'in moments of vulnerability'. He argues that 'if professional ethics becomes too exclusively preoccupied with the boundaries between good and bad practice, there is a risk that ethics become irrelevant once a therapist is securely above that line' (Bond, 2005). Transferring the context from therapy to qualitative research he is presenting a case for ethics that transcend guidelines to the person of the researcher who is safely within the bounds of good practice. How might ethics remain relevant beyond the point when guidelines have been followed?

Issues of confidentiality that are given great attention in psychotherapy have a changed emphasis in research. McNeill suggests that the researchers ask themselves the following questions:

Are there problems of secrecy, or anonymity? Is there any question of the subjects of the research suffering any hurt or disadvantage as a result of the research being published?' (McNeill, 1990, p136) .

McNeil's focus on anonymity highlights a key difference between psychotherapy and research. Research is generally published. Privacy of participants is usually preserved by hiding their identity; however participants are aware that their data is likely to be presented in a public forum. In psychotherapy however, clients (the equivalent of participants) expect their interaction with the therapist to remain

¹⁸ Tim Bond presented one of the professional seminars I attended.

privately between them. As Casement writes: “It is generally accepted that patients in analysis and therapy have an absolute right to expect total confidentiality” (Casement, 1985, p224). This ‘given’ of the psychotherapy forum means that there are implications for the therapeutic relationship if clinical material is to be published. The point is that while issues of confidentiality and anonymity look similar between psychotherapy and research, there is a difference.

Overall, I held an ethical attitude that was embedded in my conduct as a researcher and my relationship with participants. This meant as far as was able I worked on the basis of not harming participants, alerting them to possible difficulties that might arise. I collaborated with participants in thinking through ethical dilemmas that were pertinent to their taking part in the project. At the pre-interview meeting I raised ethical issues verbally, provided written handouts highlighting key issues and how the project would proceed. Furthermore throughout the course of the project I was available for participants to raise difficulties and concerns with me. I sought their ongoing consent for how I was using their material throughout the project and was respectful of their involvement. In these matters I took guidance from narrative and phenomenological researchers (Moustakas, 1994; Etherington, 2004). I now turn to key ethical issues concerning this project.

Use of Relationship

The development of trust is key to psychotherapy and counselling. I would add that it is also key to gaining data from other people as a researcher of human experience. In both therapy and research I use my relational responses with client or participant to this end. For example my responses as a therapist towards a client might include warmth, affection, passion, honesty or anger; whatever they are, during the time I am with my client I carefully examine them. At the end of the hour I withdraw. Thus the feelings I have when I am with my client are tools of how I work. I am not my clients’ friend in that they have very little to do with my life beyond our meetings, and the occasional phone call, email or letter. These relationships are my work; they are how I earn money.

Similarly as a researcher in this project, my involvement with participants was limited; most were people that I do not know in other circumstances and our actual face to face meeting was held within boundaries at the pre-interview meeting, and during the interview itself. Following that, most contact was by email, post and occasionally telephone. However during those interviews, as in therapy I used my relational self as a tool for developing trust, to encourage honesty and deep opening up from the participants. This was the primary method that I transferred from psychotherapy. The feelings I had towards participants were real and also contained within the boundary of our work together. Concerning this issue Etherington provides the following pertinent quote:

Being in reflexive relationships with our participants creates a level of intimacy that might invite them to reveal previously unarticulated, deeply personal stories. Storytelling in research can lead to new understandings, insights and revelations in ways that can parallel the therapeutic encounter. However these new insights may be entirely unexpected by the participants, who may have had an altogether different expectation of a relationship between researchers and themselves (Birch and Miller, 2000; quoted in Etherington, 2004).

These concerns led me to think about the impact on participants of talking through possibly painful situations. I offered support in the form of time separate from the arch to talk things through with me and to debrief. In the event no one took this up. Possibly this meant that the research was not in fact disturbing or that participants had other ways of dealing with residual reactions to the interviews.

Anonymity

In any published first hand material there is a question about whether or not to allow a person to be identifiable in the writing. In other words the implications of preserving anonymity and the extent to which this is possible or not.

Ethical protocol suggests that it is undesirable for research participants to be identifiable. One important reason for this is that there are implications not just for the participant but any other person that they may have talked about such as other family members. Such people would not have been party to the agreement between the researcher and the participant. Their histories would be visible. I needed to be aware that participants might tell me things they have told no one else, and their revelations would possibly hurt, upset or surprise others. Therefore this was an important consideration for this project where I was asking about participants' families. This section explores considerations regarding anonymity in more detail.

People who Know each Other

In the course of the research there were several situations where people knew each other, or could possibly be identified through their story. One of the purposes of holding pre-interview meetings was to discuss these issues and potential difficulties that might arise because of this. I found that this seemed to be an area that concerned me more than participants who did not seem to be very worried. I felt however that there were potential unforeseeable consequences for participants if they were recognisable in the text and therefore wanted to bring this to their awareness and as far as possible to follow the protocol of preserving anonymity.

Nevertheless it was impossible to ensure full anonymity for participants as some willingly and knowingly were sharing their information with each other. This was especially the case for Robin and Barbara who are both part of the same extended stepfamily group and are both mothers and stepmother of each other's children (see Biogram on page 250). The situation came about because Robin suggested that Barbara might be interested in being interviewed by me and was therefore party to her involvement in the project.

During the course of her interview Robin expressed an interest in Barbara's perspective on their family. This was the opposite of being unidentifiable as she wanted to know and be known about by Barbara.

What would Barbara's take be on it? Because people do see things from different perspectives, and I just think it's fascinating

how the same set of circumstances or experiences, or similarity in experiences are experienced and distilled differently by individual people (Robin).

It seemed that for Robin, the fact that another member of her family would be involved and would talk about how she saw their family was of interest to her; she wanted to know. As she said “an offshoot (of your project) is that the two of us are linked”. Barbara did not express the same interest but accepted that what she had to say would be recognisable by Robin. Clearly to consider preserving anonymity between these two in my writing was not only impossible but also unnecessary and unwanted.

Four other people who participated in this project were based in the same part of the country and connected through their social circle. They were part of a group of women who had known each other from when their children were young. It was probable that I was told things by these four participants that were unknown to others in their social group. It was also likely that they would be able to recognise each other through illustrations of their family structures, or accounts of their life stories. In discussion with them I understood that each accepted the possibility that what they had told me would be read by the others. With these, as with all participants I obtained consent to publish material and sent material back to them throughout the project.

McNeill, commenting on working with small communities states:

those who know the community concerned, and certainly all those who live in it will not have much difficulty in identifying who is who' (1990, p92).

His assumption is that the researcher will be told things that people may have kept secret from others and this is something the researcher needs to consider. He poses the question of where the researcher's responsibility lies; to the people who have participated in the research, to the people who will read the book, or to a particular code of ethics? (McNeill, 1990, p92) .

The possibility of disguising the identity of a participant was more difficult with a work colleague whom I interviewed. The fact that she is a colleague means that she is already associated with me and that those who know me or our work together might easily identify her and the slightest detail given will make that more likely. She is unlikely to be recognised by someone who does not know me. She has discussed this fully with me and she felt that her contribution was important enough for her to take this risk. I have not identified her beyond the fact that she is one of the participants.

My own family and ex-husband

There is an issue relating to my own family in that when writing about myself I involve my husband, children and stepson. I talked to my husband, daughter and stepson about this so that they were aware that I would write about myself and will probably refer to them. They have agreed to this, and are willing. My son is also aware of what I am doing, is less comfortable with it but also accepting.

My situation however is more complicated regarding my ex-husband i.e. my children's father. I did not want to approach him and did not consider doing so until late on in the writing. When I thought about it I was afraid that were I to ask him he may not accede and that a difficult aspect of our relationship would be rekindled. Based on past experience I would not trust him to support this work. If he were to not agree to this it would leave me in the position of limiting what I have to say about my own life, or of defying him. My ethical sensibilities are in this instance challenged by the feelings I have towards him.

The dilemma in this case is one that arises when a researcher writes about themselves and unavoidably involves other people who might be identifiable through their association with the researcher. In the circumstances where the nature of the researcher's relationship with that person means that they are unlikely to consent, then such writing is only possible without their agreement or knowledge.

On this issue Janice Morse writes:

With due respect to autoethnography, I usually discourage students from writing about their own experience. There are many reasons for this. First, the narrative is rarely their own. It includes information about others who are, by association, recognisable, even if their names have been changed. As such, writing about others violates anonymity. If these 'others' do not know about the article, it still violates their rights, for they have not given their permission and they do not have the right of withdrawal or refusal the informed consent provides (Morse, 2000, quoted in Etherington, 2004).

Sparkes writes in relation to auto-ethnography

besides the dangers of revealing intimate secrets about oneself there are also the ethical dilemmas of writing about intimate others (Sparkes, 2002, p103).

Taking on board the above considerations the question I find myself with is not whether I can proceed without my ex-husband's agreement but *how* I can proceed and *to what extent* I can write about him and reveal aspects of my life that involve him. As I have designed this project around my own experiences anyone mentioned by me might be identified. However the likelihood of this being read by someone who knows both myself and my ex-partner outside of those who already know us and our history is very slight, although even the possibility that exists might be said by some to be too much.

I suggest that what is important is the content and extent of the information I give. I have therefore decided in this situation to proceed without telling my ex-husband but also by saying very little about him and our life together. In this way, in the unlikely event that he was to be identified by a reader, nothing further would be known about him. I have scoured the text and for details of our life together and edited out all reference other than that he was the father of my children and our relationship ended.

This is not a solution that satisfies my sense of rightness in every respect but seems the best I can do in the circumstances.

Connected with this is that during the course of working on this project I changed my surname from his, to my maiden name and that of my current husband. I did this in order to acknowledge where I am in my life now. This means that I no longer identify myself with him by name and is therefore an additional protection of his identity (although our children share his name).

Choosing Names

In my previous research project (Practice Evaluation Project) I allocated names to people in order to disguise their identity. Doing this felt uncomfortable as I felt that the names I gave perhaps revealed something of hidden feelings I might hold about a person and that they might not like the name I had chosen for them. It felt like an imposition, something given by me, or put by me onto them. Because of these issues I invited people to choose names for themselves and their families. Most did this. As a result several family members have the same name. This has not been an issue in the writing up as I have made it clear whose interview I am referring to, and therefore who the different characters are involved with.

Ownership

Issues of ownership of material were relevant to two aspects of the project. Firstly, that personal information was given over to me to work with, and secondly the question of who received credit for the material when it was published. I discuss each of these in turn.

Personal Material

Once an interview took place I had in my possession a recording and transcription of a participant's tale. The participants had given me material to work with but did that mean that when I took the words away in my recorder they became something that belonged to me? Certainly I used them, played with them, thought about them and involved myself with them. I entertained the thought that these words were aspects of the person separated from that person. I felt that something of the person was in

what I took and I was not entirely clear that this was recognised by the people I had taken it from. The situation brought to my mind apocryphal stories of tribal people who didn't like being photographed, because they felt that something of them or their soul was being taken.

This sense that I had taken something from the participants meant that although I was careful to talk my project through with participants before being interviewed; they had agreed that I could use their material and signed a consent form, these activities seemed to be safeguards that were only valuable up to a point. I had covered myself and was unlikely to be sued should something go wrong, but for the participants what it meant to be part of this project, to have their words separated from them, thought about, analysed and exposed to a wider anonymous audience was unknown until it had happened. This meant that responsibility and trust was being placed in me as a result of asking people to participate and to consent. I recognised that their consent was a gift and felt that their words were precious.

In this I felt concurrent with Ruthellen Josselson (1966)

*To be uncomfortable with this work, I think, protects us from going too far. It is with our anxiety, dread, guilt and shame that we honour our participants. To do this work we must contain these feelings rather than deny, suppress or rationalise them. We must at least try to be as aware as possible of what we are doing'.
(Josselson, 1996; quoted in Etherington, 2004, p226)*

As a result of this I felt it of absolute importance that I had ongoing permission from participants to work with their material, that they agreed to the accuracy of what I was working with and were able to make amendments or comments if they wished. Thus I sent back to them the interview transcripts and the narratives that I had made from the interviews, wanting to ensure that I was representing them accurately.

When I sent the first person narratives back to participants, only three came back to me. I thought that possibly they felt that having been interviewed and given initial consent that they were no longer interested in being involved. Other possibilities are that they had no further comments, they had time restrictions or they were away at

the time. They might have moved home, but I would imagine if the material wasn't delivered that it would have been returned to me. One potential participant did not send back her transcript, although I had included a stamped addressed envelope. When, after a few months I phoned up to ask her about this she said that she did not have time and would get back to me later. I did not hear from her and did not work with her material further.

Benefits

Another explanation for why I have not heard back from people is the possibility that they feel this is my project not theirs. Having given their material over to me they may not want further involvement because that would be seen as being for my benefit. There would be no benefit for them in terms of recognition since concerns around anonymity would make it impossible to openly acknowledge people as participants. Thus any further involvement would be a generous gift from people for which they would get very little in return. Although participants are thanked in the prologue their names are still disguised. This is an ongoing issue as were I to publish a book as is my intention, it will either contain other people's material and words, or be inspired by them. If this happens there will hopefully be some financial benefit and I will be acknowledged as the primary author. Others will not receive this acknowledgement.

These considerations were missed by me at the start of the project and therefore were not part of the agenda at pre-interview meetings, nor were they raised by participants. In retrospect I should have discussed them at that point. It is possible that not doing so has inhibited the level of participants' involvement. Increased ownership of the project might increase willingness to work for it.

Similar issues arise with members of StepIn ASAP as this is a cooperative venture with six others. It is the main product of this project: I founded it and my research has influenced others. However it is not mine alone and as it progresses my role will become less prominent. I will be the only member to gain academic recognition for this organisation. At the same time the organisation provides ongoing opportunities

for its members to develop their work, so there is clearly benefit for them in being involved beyond this project. Additionally, members of StepIn ASAP are visible in this work. They are not anonymous, they are named as collaborators and supporters, and their contribution has been essential for project development.

Conclusion

This project has presented several ethical challenges which have not been entirely possible to solve. The most problematic of these are the dual relationships that I hold with some participants and questions of anonymity between people who know each other in other settings. I missed recognising that I was asking people to work for my benefit which may have caused them to be less involved than I would have wished.

It has been commensurate on me as researcher to hold an ethical attitude, to be aware of dilemmas as they arise and be willing to respond to them as necessary. In some ways these challenges might be seen to recreate situations that regularly occur in stepfamilies.

CHAPTER 5 – FINDINGS

The findings are presented in two sections. The first section consists of two first person monologues. These are the outcome of editing and re-ordering interview transcripts to create coherent ongoing texts.

The second section which starts on page 125, presents themes that arose within the research data based on extracts from the interviews. These themes arose spontaneously from the interview process (see description of interview process) and were found through comparing the transcripts with each other.

Section I – First Person Monologues

As described earlier, I organised interview material into monologues which present the stories of participants' stepfamilies in their own voices. I have included two of these monologues following this introduction. An introduction to all the women I interviewed and the remainder of their monologues are included Appendix I. on page 256.

The monologues consist of stories which may have been told before, but never in this form and never in these exact circumstances. As editor I have had some part in their creation, but my touch has been light in order to preserve the integrity of the narrative. Therefore the narratives re-present the actual words of participants, in a new order. They are not typical stories, as I found that there was no typical story among participants. Instead each mother presented a unique situation, and theme and their stories differ greatly in focus and tone.

As with fictional representation these stories stand by themselves without further interpretation. At the same time there are multiple interpretations and themes that may be taken from them and these inform thematic findings in the next section.

The two monologues I have chosen to present here are the stories of Clody and Bella as both contain detail of family life and stepfamily history provide insight into different aspects of mothering in stepfamily situations. Clody and Bella are very different characters, however they have in common that both attempted to have traditional, nuclear type stepfamilies with their second partners and in different ways failed to do so.

I introduce each of these narratives with a description of the setting where the interview took place and my thoughts and impressions of the participant. The intention is to give some physical context and an indication of how I have interacted with her. This is followed by a Genogram and Biogram mapping the participant's family structure, which provides an image of the shape of her family and a guide to the relationships contained in her story.

Clody's Monologue

Introduction

Clody was the first person I interviewed. We had known each other several years previously although not closely, however I could not remember her face until we met again. Our pre-interview meeting was at the British Library. We sat together, drank coffee and talked. I was nervous; this was my first meeting with someone who might participate in the final study. Our conversation and the areas that I wanted to discuss seemed pertinent and as we spoke my nervousness dissipated. In the course of her conversation she agreed to participate and we arranged to meet at her home in two weeks time.

I found Clody's house in an estate on the edge of a town, surrounded by fields. I rang the doorbell and there was no answer. I was worried that I had the wrong number, at the same time feeling awkward about possibly drawing attention to Clody. However Clody arrived very shortly after and welcomed me in. Her house felt comfortable with photographs and colourful artworks on the walls. It was a sunny day and she suggested that the interview take place on her garden patio. Consequently the recording has birdsong behind it. After the interview she invited me to eat with her.

Clody has been married twice. She is the mother of two boys Andy and Luke from her first marriage. She is also mother to Julia, daughter from her second marriage to Steven. Steven has three children Clody's stepchildren. She separated from her second husband five years ago.

Themes in Clody's story include her feelings as a child in a stepfamily when her mother had died: this was a time (late 1950's) when it was commonly felt that death was a subject not to be spoken of, and from which children needed to be protected. (Gorell Barnes, Thompson et al., 1998); her expectations of herself in relation to her stepmother, her attempt as a mother and stepmother to build a *nuclear* stepfamily (Church, 1999; quoted in Coleman, Troilo et al., 2008) that excluded input from her own and her stepchildren's non-resident biological parents, issues of equality of

relationship within her stepfamily. A final theme within Clody's narrative is how she is now working to repair the past.

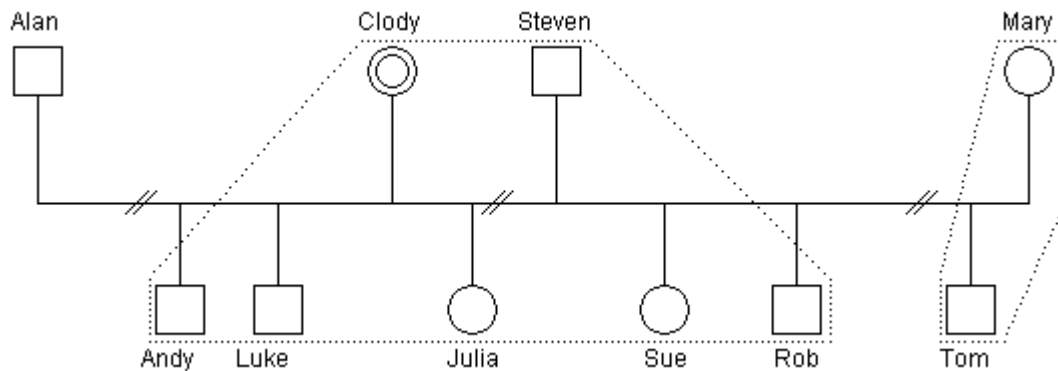

Figure 5 - Clody's Stepfamily Genogram

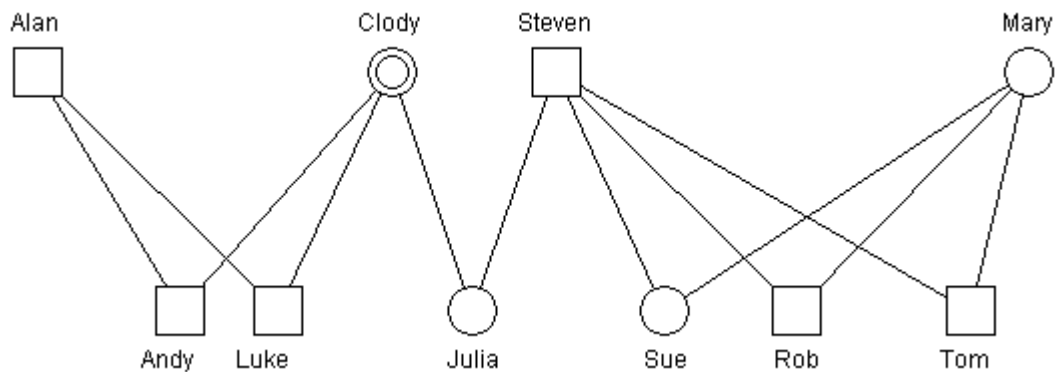

Figure 6 - Clody's stepfamily Biogram

Family of Origin

I am not only a mother and stepmother I am also a stepdaughter. My mother died in 1959 when I was eleven and my brother Joe was eight. I remember having a lovely time with her, she was so lovely and beautiful and cared so much about us. It was a happy, happy childhood until then. At the time nobody spoke about things like that, so that when my mother died people didn't ever mention her. I had really big issues about this. Why didn't they tell us she was dying? Dad apparently knew and the doctor knew but they didn't tell a single other person. I felt cheated that nobody discussed my mother and have tried to find out more since. A couple of years ago I

went to a few people that knew her then but they couldn't tell me anything about her. There's a woman who I've known since I was little, and she mentioned my mum. When I see her again I'm going to ask her about things. But this is forty five years ago, how much will she remember?

I remember that I said to Joe, 'I can't believe that she died and didn't leave us a message'. That's the most upsetting thing. The way I feel about my children must have been the way she felt about us. She didn't even know she was going to die and if she had known she would have left us a note or something. I want to leave a video or something for my kids, although they already know a lot about me because we talk.

It was very hard having someone come in her place, even though she was our favourite Aunt. She had been a bridesmaid at Mum's wedding, and was a single forty year old woman. Her mum and dad had died when she was very young, so she'd been brought up by my grandmothers' sister. My parents didn't have many friends and didn't socialise a lot so when people came to stay it was good fun. Auntie Joan would come in her little green Morris Minor and she was always laughing. Of course at that time she was free as a bird because she didn't have a husband and she didn't have any children, so she would just come and whiz around and visit people, and go on glamorous holidays. She went to Italy and to France and that was lovely for her.

All that stopped when she came and looked after us. It must have been so hard. She lived with us for six months to see how it would pan out and then she and Dad got married just up the road from where we lived. It's not that she changed, but her life changed because she'd got three bereft people to look after. It was confusing who she was because she stopped being that fun person who came and stayed with us. How awful! My Grandma and my Aunt on my father's side weren't nice to her and I didn't know what to do about that.

I've been really wicked in my life because I couldn't love Auntie Joan the same way as I loved my mum and I went through stages of not loving her at all. I always called her Auntie Joan except when I was referring to her with others when I called to her

as my mother and introduced her as my mother. It could have been much better but also it could have been so much worse. I mean she could have been anybody, it could have been someone ghastly that we didn't even know. At least we knew her, she knew the family and was part of the family.

I didn't love her like my Mum, I loved her for being Auntie Ann and she was a lovely grandma to the kids. She was such a brick and when I think of it she was run ragged by us. My brother was a heroin addict for several years, Dad absolutely fell to pieces, and I ended up in a mental hospital for several months because I was so depressed I just took a load of paracetamol and didn't even understand why. She was the one that was completely calm about it all.

Joe was much closer to Auntie Joan than me. I think that may be because he was younger, still little at eight. Maybe he needed that mothering figure. I was close to my Dad. I can see that things repeated themselves in some way with my own stepchildren. Sue my stepdaughter was sort of like my rival. It isn't difficult with her now, but I've never broached the subject with her to say how I feel, and I still feel very guilty about it.

Work History from Family of Origin to Present Day

My grandparents came over from Central Europe so my parents were first generation here. My mother didn't work after she had us, she devoted her life to us and my grandmothers didn't work at all, they made home and cooked. I didn't have a full time job till the year 2000. I'm very grateful that I didn't have to work so I could just be a mother.

Loads of my family were in the pub trade; I can't think of any of them that actually went out to work or did anything formal. All my family were hard workers, grafters and they worked long hours. I was the first one in my family to do a university degree. When I was pregnant I'd had an admin job in the place where I am working now. One of the girls said 'I've got all my Open University (OU) stuff through today and it's so exciting'. I must have registered this because I was sitting at home one day with a women's magazine and my baby, watching daytime telly and I

thought ‘there must be a bit more to life than this’ so I sent off for the OU application and I did it. I loved it, it was so exciting to be studying.

First Marriage

My first marriage to Brian was a violent relationship. I was naïve; I thought ‘we’ll build a nice home together and it will all be OK’. Things weren’t bad all the time but they were quite unnerving and there was alcohol involved and low self-esteem. I was twenty seven when I got married and became pregnant with Andy immediately. He was a wedding night baby.

I’d never held a baby till I held Andy, literally; I didn’t know what to do, I was overwhelmed by this whole mothering thing. I was so lucky I thought ‘he’s so lovely’ and he was such a great baby, he didn’t ever cry. He cried once and I took him to the doctor who told me that he’s got a tummy ache, ‘that’s all’. He was so gorgeous that I instantly thought ‘I’ll have another one like that’ and I did. I had Luke half way through my first year of Open University and I remember rushing out in my exam to breast feed him. He was a really naughty crying baby who drove me to distraction and is a completely different character from Andy. Luke was born just wild, crying and running, very cross, always fighting. He had a girlfriend when he was three. I found him in this girl’s house along the road, kissing her. It’s funny now, they’re in their late twenties and thirties they’ve changed. Andy’s the belligerent one and Luke’s a steady old boy.

After about two or three years in my marriage I thought ‘I can’t do this any more I’m getting a bit scared’ and although Brian was never violent to the children or around them I felt nerve wracked all the time so I ran away to my mother’s¹⁹. I had to return to my home but I’d made up my mind, to leave; so we lived in the same house for a while and eventually I left.

¹⁹ These are Clody’s words. As Clody described earlier, she called her stepmother ‘mother’ and introduced her to anyone outside the family as mother.

Life on my Own

I had a lovely time when I was on my own with the boys, absolutely lovely. I ended up living in a housing association brand new house in the most wonderful part of town. The boys were three and five years old and they seemed very happy. We had lots of friends and I loved it; it was my favourite.

We had quite an unstructured life although the boys did have a regular bedtime at 6.00 every night; we seemed to have lots of fun. I was working as a life model before Luke was at school and then I was studying doing my Open University. I also helped out at school teaching a bit at Sunday school. I was a bit of a lost soul really because I'd dropped out of school and had loads of jobs but never thought what I wanted to do, so I didn't have a career and my life was those little boys.

Relationship with Steven

When I met Steven and his children I thought that they were very sad and obviously they were because they weren't with their Mum. In contrast to me, Steven had a very structured life with his children who all went to bed in stages. That is how he is and I'm a bit like 'lets just see what happens'. I fell in love with Steven and I was blinded by this love so much that I didn't see all the stuff that was going on with his children. I thought that it would be easy for us to live together. I had two wonderful children and had met a man who was nothing like my ex-husband and I thought 'it's wonderful and the extra three children will be a doddle because I'll just make more potatoes'. I really remember thinking 'I'll just cook more' and that's fine".

Steven was a man who told lies and lived in a bit of a fantasy world. I didn't really notice at the time because I was part of that. At the beginning of the relationship he was living about twenty miles away with his children and he led me to believe that his ex-wife didn't want them which turned out to be a complete lie as he wouldn't let her have them. We had problems with his eldest Tom who didn't want to have anything to do with me or my children; he wouldn't speak to his father and was literally catatonic. He went back to live with his mother I can't remember whether it was before or after our wedding.

I met Steven in August and by Christmas he had found work abroad so he proposed to me and I accepted because I couldn't have gone with him as anything but his wife. We got married in June that year and went to live overseas for 3 years.

Steven and Clody's Relationship with the Children and Each Other

Steven and I went abroad on a Tuesday and by the Thursday I could see that it was falling to pieces. I really didn't understand why it wasn't working in our little bubble. It was as if Steven changed as soon as we got to the house. It was a lovely house with four bedrooms. However he had arranged it before we got there so that we were in one room, his children Sue and Rob had a room each and Andy and Luke were sharing. There was no negotiation. Actually the children sorted themselves out and used to swap their rooms on a monthly basis. At one point there would be four of them in one room together having fun and then they'd all change round. When Julia came along a year and a bit later we put her in a room of her own just because she might have been disruptive because she was a baby.

My boys didn't have much contact with their own father but that was probably my fault. I didn't tell him we were going overseas, because in my fantasy I felt I didn't need either him or Steven's ex in our lives. I wanted them both to move away and not get in contact again. I even thought we should change our names so we all had the same name. Luke remembered that (I don't know how because he was three) and how upset Brian was. We didn't do it, it would have been too complicated.

Things just went from bad to worse, Steven couldn't seem to be nice to both my boys at the same time; if he was being nice to one of them he was being horrible to the other or else he was being horrible to both of them. It got to the point where I never ever went out on my own because I didn't want to leave him with them, I thought he would be cruel.

My son Luke wet the bed till he was ten and Steven didn't change the bed. Luke was sick one night and Steven was cross about it. It upset me, poor little thing! He did not want my boys in photos with him and his children and he would introduce us saying 'this is my daughter Sue and my son Rob and these are Luke and Andy' I remember going to the school playground once with Steven and I heard Luke say to

a kid 'there's my Dad'. I told Steven that, saying 'its so lovely' and Steven said 'I don't believe you' but I was there, I saw it and heard it. The other thing that happened that was really upsetting was that at bedtime I'd read a story to all the kids and then Steven would read a separate story to his children so mine would miss out. It turned me against his children. I couldn't include his kids if he couldn't include mine and it went on really until they left.

Sue his daughter, the youngest of his three was his favourite and carried on being the favourite even when we had Julia who is the youngest of them all and also a girl. I felt awful and am sure that the children felt awful – or maybe they didn't, maybe they didn't care so much. I can't bear to ask them really, I don't want to rake it all up. You know they've all got their strong points, why does he have to focus on her all the time.

I found Steve and Sue's closeness hard, she would sit on his lap and I would come in from doing the washing up and feel really excluded because I thought 'if you've got one on your lap you should have all four'. I wouldn't hang Sue's clothes next to his on the line I just couldn't bear them to be close on the washing line. At the time though I was worse than Steven because I was covert about it, so I wasn't overly nasty like he was but I would do things. When I say I wasn't very nice to Steven's children, it was mainly Sue. I was very jealous of her, *incredibly* jealous. Because I thought 'why can't it all be equal and all the kids get the same or equivalent?'

When I got my Open University degree Steven was a year behind me and he got his thing saying that he'd passed that year, and said 'would you mind telling people that I actually got my degree. He couldn't bear it, he always had to be top dog. So Sue fulfilled that for him as she was so driven and succeeded in what she did. She was brilliant at school and brilliant at her exams, brilliant at her sporting stuff and she did well at uni. She is now a lawyer and I feel 'good for her' but you know there was a bit of me that *wanted her to fail* at some of that along the way, because my boys dropped out, they dropped out of everything, they dropped out of life; but they're back in it again now.

As the boys' mother I was acutely aware of what was happening to them when we were all living together and now I feel mean that I didn't do anything about it. I talked about it to Steven but we just had row after row and he would have none of it. These rows were often late at night, way into the early hours, they'd end up with us having sex and nothing would be different in the morning.

I am unclear now whether what was keeping us together was the family rather than our relationship, because if you ask me how I feel, I hate not having a partner, I hate being on my own. So it may have been important for me to be with him in ways that I didn't recognise. Also Steven wasn't supportive as a husband, but financially it was great which meant that I didn't have to work.

The thing is, if I were to finish the relationship where was I going to go? I had no career, no money and at this point I was overseas? I'd be splitting up this family that I'd really wanted to be together and that was the most important thing for me. I was going to make a go of it because this was the commitment I had made; even though it was a bit odd and excluded the other parents. I thought that I could not make another change in these children's lives because they'd been torn apart once.

Things changed between me and Rob half way through our time overseas. He said he wanted to go back and live with his mum and Tom was already there. Steven and I were horrified and we got the army equivalent of social services involved. Now Rob says that he doesn't know why he wanted to go. Maybe it was because he didn't want to share. I remember that I was heavily pregnant with Julia at the time. Eventually he changed his mind and it all started to alter after that. We have always been very very close and he's always been close to Sue.

A child of our own will fix it all

I thought 'when we get Julia its all going to be alright' she would be a new little person who would be the glue to hold us all together because she was part of us. Because we were like two separate units with Steve and me having fantastic sex all the time right to the end. I thought having Julia would mend it all and I still thought 'I should really end this' but I couldn't.

I was delighted when Julia was born that she was a girl. I didn't know what to do with a girl because I'd only changed boys' nappies. The kids just doted on her. I'd had a miscarriage before Julia so that was a bit upsetting but I got pregnant immediately afterwards and when we brought her home they all queued up and sat on the settee and had to hold her. I can barely remember her being a baby because I'd got a house full.

I had to share every aspect of Julia really; I mean she had to share me with all those other people, even though I was at home with her and they were all at school. Rob said he used to creep in from school and hear me singing to Julia. He'd creep upstairs and make me jump. I really enjoyed having her and she and I were inseparable until she was about fourteen. I used to take her out of school and whiz her off to London to exhibitions. That was in the days when you could do that and the schools didn't mind too much. She used to come with me everywhere. Then I think she thought 'this isn't really very cool so I'm not going to stick around any more with my mother'. She was just like a little friend, and now she is twenty two we're really close, but I'm not closer to her than the others.

Unequal treatment

When Sue finished her A levels Steven took her round the world on a trip. Just her, not me, not Rob, not Tom and not Julia; so me, Julia, Andy and Luke went to Australia for two months in the summer. We stayed with my family. My sister in law was in hospital some of the time so I worked in my brother's shop. Luke was being really difficult and we had a big falling out. Steven and Sue joined us there for a couple of weeks on their way round the world.

Rob was already at university and living away from home. I said to him when we all eventually got back 'I've just had such a horrible summer' and he said 'I had a horrible summer too'. I had such a horrible time wondering why Steven would take just one child away for the trip of a lifetime. It's just so unfair.

At one point Luke said to me 'I just feel horrible, I haven't got a male role model in my life'. He wasn't in touch with his father and he didn't want to be like Steven. I said 'use my brother Joe and my dad' which was fine and when Luke was getting off

drugs he went and lived with my family for the Summer. He rang me and said ‘I can’t be in this aftercare place any longer, I can’t be here please let me go to Joes’, we bought the ticket on my credit card and sent him off the next day. He lived with my Dad who didn’t know that he was doing rehab, but Joe obviously did and helped him. My parents looked after him and he looked after them; it was lovely.

Reflections and outcomes

Nothing makes me more angry than inequality, and justice and equality have been a huge thing throughout my life. I now work to make sure that people get equal treatment in the community and that each person is celebrated for what they are. I’ve got one brother and we were always treated completely fairly. My family with Steven was rife with inequality and I regret that I was a perpetrator of that.

I now see that I was in a fantasy world and had this husband who was in a complete fantasy world. Its all these fantasies within fantasies. What I wanted was to have this little cohesive family, a new family with no distractions and me making lentil pie for everyone. (Of course nobody would have eaten it if I’d made lentil pie). I wanted somebody to be a dad for the boys and what happened was that when Steven didn’t do that the stepchildren lost out on having me as a mum because I wouldn’t give enough of myself. I felt at the time that my motherliness was rationed and I thought ‘I’m not going to do it because I’ve got to give double to my boys because they haven’t got a Dad, so there’s nothing left over for the others’ and actually that’s not true because it’s an ever flowing river.

I have a fantastic relationship with my stepchildren now; not the eldest one Tom because I rarely see him, But he’s estranged from my kids as well as his siblings though I do occasionally see his wife. We don’t tend to discuss Steven. It’s as if he doesn’t exist.

Now I’ve got all these wonderful children who I’m very close to and I feel regret because there was time wasted; all the time wasted rowing and worrying and being sad and being angry. What a pity, all that energy could have gone into good stuff. It’s such a waste.

Bella 's Monologue

Introduction

I thought of Bella as a gipsy mother because of the fluidity of her physical circumstances. She has travelled frequently during her life, no longer lives in the country she grew up in and has moved home many times in this country including a period where she lived in a caravan. She has also moved through three different relationships before the one she is in now.

Bella's house was full of her pots, her partner's ironmongery and his collection of eclectic objects. Her kitchen was full of people. I was offered a cup of tea and quickly found myself involved in comfortable conversation round the table. I got the impression that hers is a busy and sociable household. She and her partner are clearly creative and enthusiastic with it. I felt quickly at ease. After tea we moved into her living room – I sat on a sofa that wanted to swallow me. All around were shelves with bits of driftwood, pots that she has made, bits of ironmongery made by her partner.

Bella's story illustrates a stepfamily where the mother provides stability and continuity while her relationships and living environment change. As the main carer for her children she became increasingly independent as she moved through a series of relationships with men who were unable to fully take on the tasks involved in being a father or stepfather. Her story includes the difficulty of leaving a violent relationship, developmental issues in the father contributing to family breakdown in her second relationship, the drive for children to connect with their biological parents and the power of those relationships.

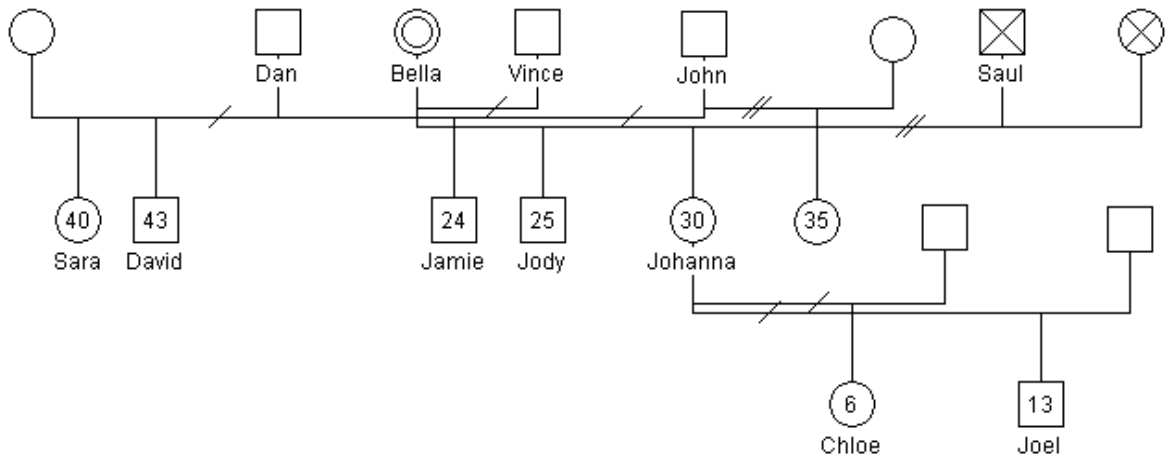

Figure 7 - Bella's family Genogram

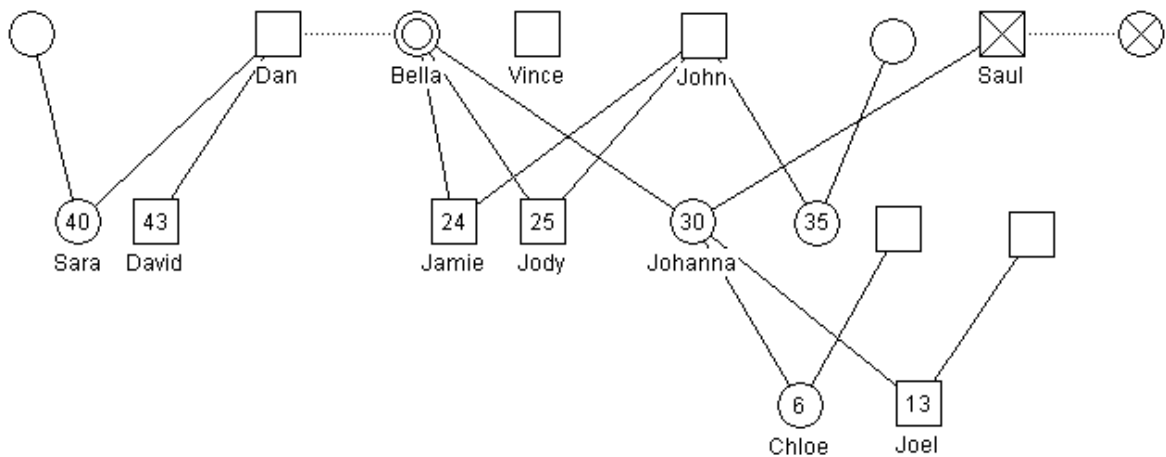

Figure 8 - Bella's family Biogram

Meeting Saul – first partner

I left home after leaving school at fifteen and was living in a very bohemian kind of setting in a place that was renowned for alternative living. I was drawn to that kind of life. I used to hang out with musicians and had a job on weekends working in what's now called a disco; it was a dance hall with records and juke box. The rest of the week I was free to do whatever.

I was nineteen when I met Saul whom I initially didn't like all. I thought he was a big ego maniac but he was a poet, so I was impressed. He was a bit of a naughty boy, he went off to prison twice for petty theft in the first couple of years that I knew him. My friend and myself started writing to him and we got closer and closer through writing, so that when he came out of prison, I met up with him and we were together from that moment on.

First pregnancy

At that point, which seems like another lifetime now, we both got into heavy drugs. We were for a while completely without care of our lives or anything else. Then Saul started having real trouble with his heart and the doctor told him that if he didn't stop using he wouldn't have more than six months to live, so we stopped. We had got married by this point.

So Saul and I left and went to the country to get out of the scene. We found jobs fruit picking in the open air and got healthy. Then I found out I was pregnant, so we came back to town and he got a straight job and I went to work until I was starting to show and couldn't keep it hidden any longer. After that I just stayed home and had Johanna a few months later.

Life with Saul and moving to England

Saul was very difficult; domineering, aggressive and hard in his attitude towards people. He had a superior attitude and I used to loathe his temper. He was a big bloke and he used to throw me around the place although he never actually punched me. That started causing splits in my feelings towards him and we separated at one point.

One night, he went out and came back the next morning saying he'd been busted on a big dope deal. I asked "how come the police didn't come back here?" and he said he'd talked them out of it by telling them that his wife and child were at home and they didn't know anything about it. I assumed that was true. The next day he had to appear in court and he was allowed out on remand but was going to get a custodial sentence because he had previous convictions; so his mum paid our affairs off back home and we did a runner to England.

Saul had never drunk at all when we were in ***** but when he came over here he started drinking and getting more and more out of control. We got involved in following a spiritual teacher and he packed in the drinking for a while and became very spiritual but that didn't last and he started drinking more and more heavily. He was hanging around with a mob of people in the town who called themselves the wrecking crew and they used to get as out of it as they could and deal in front of the police, thinking that they were cool. He was also having an affair with a girl that lived around the corner. I ended up having a scene with a young man from our circle of friends who was like a breath of fresh air in that he was simple and gentle and completely opposite to Saul.

Leaving Saul

I left Saul and went to live in a squat which was a big thing happening up here at the time. It was difficult to leave him; I left three times and went back. It was an impossible situation. It was like I'd given up my own power and I was just doing whatever happened to be happening at that time without real thought. I was just dealing with things, not really thinking and trying to keep Johanna's life as normal as possible.

We had some friends who lived a couple of doors away and had kids her age and they used to walk to school together. Saul was out and about a lot but I didn't feel as if I was on my own. He was around enough to feel as if he was there, but he was a nightmare. I didn't really know what was going on with his life because he lived it outside I just used to let him get on with it. He was the sort of person that if you tried to have a go at him about something, he would come down on you like a ton of bricks. You couldn't do it.

The third time I left Saul wouldn't let me take Johanna. He was violent, completely out of his head on I don't know what and threatened all sorts of things; he was really scary, so I had to run away from him. We went through Christmas together and on Christmas day there'd been people around but the next day it was just crazy. We sat there in the sitting room and it was so obvious our relationship was over; there was no going back, so I got up and left. I couldn't take Johanna with me at that point

because he wouldn't let me and I felt I had to get out for my own identity; to keep myself intact.

Up till then my motherhood had been dominated by Saul and the ridiculous relationship I was in with him which was the most powerful thing that was going on. Saul was difficult and domineering. He used to try and tell me how to think; he would impress a certain attitude on me and then get really uptight if I didn't actually think that way. It was hard for him that I was different and had my own thoughts. He was probably attracted to my independence but he didn't want me to be independent from him. Johanna had to take second place. I treated her like a separate issue and did what I could to make her life as normal as possible. We'd go to school and school plays, have her friends to play with her. I haven't even now thought on a deep psychological level about what was happening. It was just what happened.

I couldn't really approach Saul but I went back because he had Johanna. He was looking after Johanna but very badly. There'd been a couple of stories; including one that Johanna had been locked in the house and just left her there and she'd been calling out of the window. Eventually I thought "I don't give a stuff what he does, I'm going to go down there and demand that I see her" and I marched in saying "I'm not having this kind of thing". I ended up playing into his hands which was good because he'd decided he didn't want to be a single parent, he wanted to go out partying. So he arranged that I'd come see Johanna every weekend. I'd come pick her up with John who was the young man I'd had an affair with and was now my partner and sometimes she'd be there, sometimes she wouldn't be. Sometimes she'd still have the same clothes on that I'd dropped her off in the week before that kind of thing; she was quite – neglected.

Saul went to prison and got nine months. I think he did six months of it. and when he came out, he decided that he was going to leave and that he wasn't gonna have any contact with Johanna as he didn't want to be a part time father, it was all or nothing. So he left and I didn't see him again after that. Then I was with John and he was Johanna's stepfather.

Saul and Johanna

Although Saul had neglected her at times, I think they had a good relationship. There was never any violence between him and her. He wasn't a nurturing, caring kind of person, making sure he took her to the swings, but they still loved each other. He wasn't prepared to be the father that was not in the family so he went to live in another town. I think he contacted us once, one Christmas soon after he left to see what Johanna wanted for a present. He was supposed to meet me and we were gonna go and buy a present but he just didn't turn up. And that was the last contact we had at all.

Johanna went to find Saul again when she was about eighteen and there were still people around who thought he was a great guy. He came up and they all went out for a meal but he was just pissed and then just started getting abusive, slagging everybody down and acting like a complete ass. He went back to ***** and I don't think they saw each other again until she managed to track him down when she was twenty one – after she'd left home. (She left home when she was nineteen). I don't know if he'd decided he wanted a relationship with her by this time but they started talking to each other on the phone. He'd sorted his life out to a certain extent because he was the assistant manager of a cleaning firm that did Rover cars down in *****, but he was still drinking and smoking dope heavily. He'd go to work and handle that and then he'd go home and get pissed as he could. He was stoned all the time because he was one of those people that are unbearable if they don't have a smoke; he was raw and everything would make him angry like a big bull.

Johanna was having trouble getting work up here and was getting fed up with the locality so she decided to go down to *****; he got her a job and she started living there. He was married, but his wife had cancer and Johanna ended up nursing her until she died.

Meanwhile, Saul was still drinking heavily and he'd messed himself up physically. He'd had a by-pass operations and was getting quite disabled through his over-indulgent life. He'd had various accidents on bikes from falling off of them when he

was drunk and had broken bits and all sorts of stuff. He didn't care whether he was gonna die or not.

Johanna started finding that very difficult. By this time Johanna had both her children and felt she couldn't run around after him; she found it really difficult. He was still a very heavy character. He was demanding of her attention. When he was in hospital, he'd ring her up and say, can you do this, and this, and this. He would offer everything, give her money for doing stuff then, when she didn't turn up when she was supposed to, he'd say that she only came to see him for the money. They'd fall out and then not fall out. When she got in contact with him he would overdo it and would be on the phone to her a couple of times a day and he'd be pissed. She couldn't handle it so she tried to keep her distance.

Eventually two years ago, he fell off his bike again and perforated his bowel. At that point they were still estranged and she didn't know about it until the hospital rang and said that he was on life support and that if she wanted to see him, she had a couple of days before they were gonna cut off the machines. She went to see him and by that time he was all pinched up with tubes everywhere and she couldn't communicate with him. She stayed with him on the day that he died but had to go and pick up her daughter from the school. I think she left at 2:30 and at 4 o'clock they rang her to say that they were turning off the life support gradually; so that was the end of him.

Johanna's feelings about her father and stepfather

I spoke to Johanna inspired by you coming. I thought "hang on, what did she think?" and wondered whether or not she felt this absence of a father. I think she did, but I don't think she was lonely or broken hearted about it; she didn't seem to be. The fact that her dad wouldn't contact us was quite bad for her and she had to accept that. I suppose she'd seen certain things happening but he was out of our lives and he wasn't about to get in contact, so there was nothing I could do about it anyway. If he wanted to see her he could have got in contact but he never did.

In regard to her stepfather John she said that she felt a distance from him until she got into her teens and then she started to get closer to him and could relate to him

more and probably he could relate to her more. From my perspective he was fine with her and she was apparently fine with him. He wasn't her father but he did treat her like she was his own.

Two boys

Since I'd had Johanna, I'd hardly used any contraception but I'd never fallen pregnant, I had gone to a fertility clinic and they gave me the fertility pill; I still didn't fall pregnant. So instead of pursuing that I decided that I wasn't gonna have any more children so instead, we'd save up, go to ***** (the country where I grew up) and start to travel. Johanna was older by then and was dying to go over there even though she was young when we first left, she'd always wanted to go.

So John and I saved up for a year. I was working in an office and he was doing taxi driving. We got over there and after only a month when Johanna was thirteen I'd fallen pregnant. We settled down in ***** and then I had this fluffy little boy Jody. A year later, I fell pregnant again and had a second little boy; Jamie. Johanna really enjoyed having the boys around and used to take them out for walks; but she was also a teenager and had a big circle of friends that she'd met at school. So she was out and about a lot doing her teenage thing.

All Bella's time taken up with babies; John's personality change

John and my relationship changed when I had the boys. Johanna and I had come along as a unit and she hadn't been a baby when John and I were first together. When I had Jody and then Jamie so close together, all of my time seemed to be taken up with babies and John wasn't able to make the adjustment to me not being there for him. He was nine years younger than me and he now seemed immature. I don't think he was mature enough to handle that even though he'd seemed a very mature man when he was younger. It was strange. He just didn't have what it took to be able to take on the role of a father who has to stand back from the wife for a while because there's two kids all of a sudden and they're taking up all of her time.

It was weird because he'd done a personality change. He used to be really laid back and if anybody needed any help he'd turn out any time of the day or the night but he became the opposite. He was grasping, not helping and wanting things for himself in

a very awkward way. For example when I had Jamie and Jody was nineteen months old John was working on the buses in *****. He was on shifts and after you've been there for a while you can start choosing the shifts you want. He chose shifts that meant he didn't have to get out of bed in the morning and it meant that he'd have lunch before he went and then work until 8 or 9 o'clock; sometimes 10 o'clock at night. So he was gone in the times when I would normally be able to spend time with him, and the time that he was there I was rushing around with two babies that needed a lot of attention.

John wanted time when I didn't have time and wouldn't give any when I did. He would insist that he had a big meal before he went to work because he wouldn't come home in his evening time even though he only worked about ten minutes drive away, and got a good break in the evening of over an hour and a half. If he'd done that he could have come home and had the meal when I had time to prepare it and the babies would have already been in bed. He wouldn't do that, so I'd be rushing around in the morning getting food together with the two babies and if I didn't make him sandwiches or something to take for the evening meal he wouldn't have anything and then he'd complain about his stomach. It was like he was gonna grasp this bit of attention and time even though it was obviously a very difficult time for me.

It was an incredible responsibility to be a mother and I needed him to be in the supportive role but he became like another responsibility. I think he was jealous of the time that I had to spend with the babies and I expected him to be mature enough to recognise the situation and to take a step back as far as our relationship went; but he couldn't. Maybe he felt that his role was going out and making some money and suddenly I didn't need him. I felt with all my children that it was an incredible responsibility to be a parent - or to be a mother and looking after him wasn't my main purpose.

John started off happy being a three person unit and when Jody was born Johanna was off doing her own thing a lot so it was easy for him not to feel excluded because I still had time for him. But by the time I had Jamie and because of the hours he was

working, I didn't have the time any more. We'd talked about the possibility of having the kids minded and me working and that but we decided not to do that. But the difficulty wasn't just about that; John had always been a very soft man who was quite comfortable in women's company and didn't go off and do man things with blokes but when he went to work for the buses he got friends who were all kind of bloky blokes and he started going off with them just at the point when I felt I needed him around. When I had Jody he was going on weekends to the rifle range shooting and when I said something to him about it, he said something like, "well there's more to life than just babies and families" and I thought "now he tells me". So he distanced himself.

Moving back to England to be with like minded people

Though ***** was home in inverted commas I couldn't really feel like it was. I had a lot of friends over here with kids. I did have friends from when I had lived there before but our lives had gone in different directions. I was in my thirties when I had the two boys and most of their kids were already half grown up. The way of life was very different from life here, nobody would stay around and look after their kids; it was like, pregnancy, six weeks leave and back to work. I didn't want to do that, I was looking after my kids. A lot of my friends back in England were not actually earth mothers, but were putting being at home with the kids before careers and stuff. So we decided to come back.

By the time I had Jamie I wasn't working. John was working and keeping a family of five and though there was more money there than he would have earned here we couldn't save up enough for all of us to come back together. He decided it would be a good idea if I came back with the boys and go and stay with a really good friend while he and Johanna (who had left school by this time) would stay behind, save up for three months and then follow us. So I did that.

In ***** John and I were still really close and talked over everything. Not deep psychological stuff, but all the details of how we were going to do things. Then it seemed like he matured or grew up and not into his better qualities. I don't know how to explain it really. I'm still in contact with him and I know the lady that he's

with; he's now very stubborn and will cut off his own nose to spite his face and would rather do that than make things easy. I still wonder what happened to him and imagine that the whole thing was too much for him, he was taken out of his comfort zone; he was taken away from everything he knows here and he couldn't handle it. I don't know though. He says that he still longs to be in ***** and yet I don't think he really found his niche over there.

Relationship with John deteriorates

When I came back here I went to stay with my good friend who had two younger children still at home and two late teens who were on the verge of leaving. We were all in the same house and it was obvious that it was just too much, so after I'd been there for a while I went to the council and they gave me a house as temporary accommodation. I moved into the house, and it was a nice little terraced house. Some friends helped me do it up.

By the time John got back I'd been here three months and the time apart didn't help matters. It was like he didn't want to be in the house and was very awkward about things. I couldn't work out what his attitude was about. In hindsight it was like he didn't want anything to do with the house. Anything that needed to be done there he seemed not to be interested in. For instance the kitchen was completely un-modernised; it didn't have cupboards, or any stuff like that so I needed a work top to be put in alongside where the cooker was. He did it but he dug his heels in and did it with really bad grace. I should have gone out and learned how to do it myself!

We'd just had all this cheap carpet put down throughout and one night we were sitting and he was drinking a glass of wine and he spilt it all over the floor. We just sat there and I was waiting for him to get up and get the mop and I said, "aren't you going to clear that up?", and he said

"no"

"Well why?",

"I just can't give a stuff"

It turned out that he hated this place and had never wanted to live in it. The whole street had very bad memories for him because when he was walked to school by his mum they walked up this road everyday to school and he'd always hated it and he'd hated school. So presumably that's what it was about; he didn't want to be there.

He bought a truck and decided to live on the road, so he did it up into a live-in van. What happened was that when I left to go to ***** I'd left my council house in the keeping of some friends who were paying the rent in my name. They had a great big row with the council and refused to pay any more rent and when I got back I had a bill. They didn't want to have anything more to do with us and we were stuck with the debt. John stuck his heels in and wouldn't pay it off. When we went back to get some of our things we found that the council had put a repossession order on the house, so we found an open window got all our stuff out and left the house.

We lived in the van on a bit of land round here; but our relationship was very, very, very wobbly. Jody was three and a half. And Jamie was two and a half and it was awful. I didn't want to go and live in this van but it was summer and we were outside. We weren't getting on at all. (It sounds so bad, my life, when I talk about it).

Meeting Vince and leaving John

I met this other bloke Vince who lived on the same bit of land and he started hanging around. He was based about three quarters of a mile down the track from where John and I were. He was a very charismatic character who had horses and a gypsy wagon. We were eyeing each other up and we both fancied each other.

Up until this point I had determined to stick with John. The fact that I'd brought up Johanna without her father had gone deep, and I did not want to bring up the boys in the same way. It'd got to the point where we'd talked about staying together for the children, cause we still got along as friends, but our sex life had finished. Things came to a head, and I decided that I was going to leave John and that was because I couldn't cope with having sex with him anymore. I was completely closing down to him and I just felt like I wanted to be left alone.

I left John sitting in his truck in the middle of a field, and went to stay in the other caravan with Vince and the boys. It was ridiculous.

Vince, John and the boys.

At the time I thought I couldn't move in with Vince because he'd lived a very quiet and solitary life on his own with his couple of caravans, his gypsy wagon, horses and dogs. He did live a quiet life but he was also quite attractive and had relationships with lots of the women around. Of course I didn't know anything about his history at the time. Vince was very good with animals and kids but not so good with adult relationships. So we'd been together for only about six weeks and he decided he didn't want to be in this relationship with me. I brought my own caravan and I put it on another piece of the same bit of land. So there was Vince, John and me with the boys in the middle in another caravan, and we all lived there.

After I'd split up with Vince I moved to another place and then to an old garden. We had the big wind when I was down there. It was a great life but tough. I used to have to go down the track about quarter of a mile, over a fence, to the horses' trough, fill up with water carriers, take them back to the gate and shove them over. I had a big caravan and a little caravan that I used for the boys' bedroom. We had the run of this garden, and we had the loo sitting out under an apple tree. It was a really good life.

Aftermath of separation

John was still seeing the boys though he didn't see any reason why he should make arrangements in advance, or square it with me in regard to when he was going to see them. He would just turn up and they were expected to go with him. We were at loggerheads by then so I wasn't making things easy. I didn't want him turning up and taking them whenever he felt like it so that I and the boys didn't know where we were, I thought he should arrange it with me first and I didn't want to be flexible about it. His attitude was "why should he, they were his kids, he should be able to come and take them any time he wanted".

I went to a solicitor and got him to write him a letter to say that I wanted John to make arrangements in advance. Meanwhile he'd got together with the woman that

he's still with now. She came over and suggested that we have a break from each other for a certain amount of time so that I could get settled in and used to not being with John and vice versa. I think we agreed on two months. During that time I got the contact sorted out through a solicitor. Then I moved out of the caravan into a temporary winter let. That was the year when there was the big snow in 1987 I think it was. There were blizzards up here.

About Vince

The situation with Vince was that sometimes he'd turn up and we'd be together and then he'd decide he didn't want to be in a relationship and he'd go away again.

When the second winter approached I got a winter let and then a lovely flat just down the road, into the rectory there. Vince moved there as well but into a separate flat not with me, so he was there for the boys and then not.

Vince had been brought up in children's homes, he'd been taken away from his parents at the age of eighteen months the first time. I think by four he was taken away permanently, so he'd got a very hard shell and people weren't gonna get in too close. He'd get scared if things were going well, and he'd get scared if things weren't going well. Sometimes he'd leave if we had a row and sometimes he'd leave when things were really good. He'd just leave and then come back.

He was like a bit of a stepfather, but he wasn't really in that the boys never would have thought of him as their dad. The boys couldn't rely on him always being there so I never allowed him to take on really the role of stepfather because I knew he was just going to split any minute. When he was there he would just do everything with them but he didn't want to commit himself. Even so he did have quite a lot to do with their upbringing though he wasn't really in the role of stepfather, because he wasn't there permanently, and wasn't prepared to take them on as his own kids.

I'd spoken to John and said that if he wanted to we could have shared custody so that we could both have them half the week. If he'd done that he would have been housed by the council into a place big enough to have them. But for some reason or other he didn't want to do it. He moved in with Rosie his girlfriend. She's manic

depressive, and found it difficult having the boys there every weekend so they worked it out to have the boys every second weekend. So that was what happened.

I was on my own but with a boyfriend that used to turn up and leave, turn up and then leave I tried to encompass that with all my understanding. Then it just got ridiculous with Vince. I thought, “what am I doing? How long am I going to put up with this” so I went back over to *****.

John’s relationship with his sons

John wouldn’t do the kind of things you would normally do for your kids, whether you’re with them permanently or not. He wouldn’t give them money because he wasn’t going to buy their loyalty and he wouldn’t buy them presents because he thought they’d expect things from him. I think that was more to do with me than them in that if I wanted to leave and not be with him, then I would have to provide; he wasn’t going to. So I was the main figure in the kids’ life.

John’s stuck to the same attitude even up till now; he’s still withholding. There were a couple of times when Jody’s been in dire straits in ***** because he’s been out there for four years. He’d be in situations where he needed money and John just wouldn’t even put a tenner in to see him through the two weeks until he got paid. He’d say “Oh I don’t feel inclined to do that”. Jamie, the younger one sees him quite often. They go out for bike rides together.

Life now

I have had a difficult relationship with Johanna; I have more of a volatile relationship to her than I do with the boys. She was very demanding and wanted to rule the roost even as a kid, so there was always a bit of a thing because I wasn’t going to let her do it. But we’ve got a good relationship in that we can talk about anything. She’s just about to move opposite here now. She’s got two lovely kids and she’s a really fine person but she’s got difficult sides to her still.

I’ve always had a good relationship with the boys I think I did it alright with them. John says things to me like “you’ve done such a good job with the kids”. I suppose

being a mother is doing a job, but the boys are people in their own right and they were good kids.

I can see in my life that I didn't really take control. I controlled things within the situations I was in in as much as I left when I needed to, but Saul, was this incredibly powerful character who I was just swept along with and Vince was also a powerful character. I never got much emotional support from a man. John was supportive to start with definitely but he changed. It's a mystery to me, what happened to John.

I think I've been quite clear about where I've been with them and the life that I've led. It was a bit crazy you know; I had a bit of a crazy life.

About Dan

I knew Dan many years ago, and we lost contact when I went to live in ***** before I had the boys. At the time he was married, and I was with John. There was nothing going on between us but I remembered him very well and with great affection. I put an ad in the lonely hearts in the paper and he answered it. It was amazing because he'd always thought doing such a thing was naff and so did I. Now I was on my own and he was on his own. We went out one day and that was it; we've been together ever since. It's been good.

The boys and Johanna all think Dan is great. There was never any question of Dan being a father figure because the boys were both grown-up and, I'd been on my own for ten years with them. It was probably a relief for them when I got together with somebody. I remember Jody saying that if I'd still been on my own maybe he wouldn't have buggered off to *****.

Just about the same time as Jody went to *****, Jamie left as well because he got a job with shift work, and he couldn't get to his work from here because he didn't have transport; so they both left home at the same time. Jamie now lives near here with friends in a shared house, and Jody's in ***** living a life of riley up in the tropics, and having a great time.

Jamie also seems happy. He hasn't got a girlfriend but seems to have a good life. He thinks Dan is absolutely great.

Johanna has two children. She fell pregnant, got married and had Joel. That relationship didn't work out so they got divorced. Then she got together with somebody else and had her second kid; a little girl. She split up with her daughters' father a couple of years ago. She's always been interested in blacksmithing and Dan's been teaching her. He said to her "look I'm not going to be doing it much longer. If you're serious you better get yourself up here" She started coming up every month and working for a couple of days learning blacksmithing.

Meanwhile she put her name down on the exchanges list and she's just got a place virtually across the road, so she'll be able to go off with Dan a couple of days a week and I'll be here with my grandchildren nearby which is really nice. Dan gets on really well with all of them. He has some concern for Johanna which comes out in telling her what to do, but she's very tolerant of him, and knows that he's got her best interest at heart so she lets him rattle on. She said once she's up here and is in her own domain she'll give him what for if he needs it. But they're fine; they can be completely honest with each other.

Conclusion

The two monologues that have been presented here are of very different women. However in common they both attempted to build traditional, nuclear style families with their second partners. Each in their different ways failed to do so. The next section contrasts with these individual tales as it consists of general themes that have arisen through putting together all the interview material.

Section II – Themes

Introduction

The themes that follow have been organised to show what participants had to say about themselves as mothers, how they related to the different members of their stepfamilies and issues that arose within their families. The overall focus is on stepfamily structures and the mothers' contribution to their stepfamily dynamics.

I first briefly present two earlier models for organising the themes. These were i) Domains of Influence and ii) The search for the good father. They provide some insight into the journey I have taken in presenting my findings, however I discarded them as I found that I did not have enough corroboration within my data to present them fully.

i) *Domains of Influence*

The first framework that I worked with arose through thinking about mothers from a Gestalt perspective, as being field events. In this I considered how the participants were constantly changing beings who were the outcome of many influences. These influences could be clumped together into larger groups or domains; for example history, social sphere, psychology, culture and so forth. The groups of factors or domains combined differently in each case to constitute the woman before me, her story and the shape and style of her family. While realising this is not an exhaustive list, I identified the following domains:

* *Historical Domain – family of origin and current family*

This is the domain of childhood relationships with the key people in a woman's family of origin. This influences her relationships with men and includes the expectations of herself as a mother, of fathers and of her family. There is also a historical dimension to a woman's *current family* - her stepfamily. This includes how the stepfamily came about, whether the division of a parental relationship came through death, divorce or separation and the history of individual members within the stepfamily.

* ***Biological Domain – primitive feelings, intuition, genetic preference***

This domain is about those feelings that people have towards those with whom they are biologically related. These feelings arise around biological relationships, whether or not biology is the cause of them. This includes different sets of feelings a mother has towards her own children and her stepchildren, the potential rivalry between current and ex-partners and the attachment between parents and children. It seems that differences in feelings towards biological members of the family as contrasted with non-biological are often the basis for stepfamily difficulties.

* ***Societal Domain - Roles and expectations & cultural/peer group***

This domain includes a woman's expectations of herself and self-image in the role of woman and mother, her expectations of a man and father and of herself and/or her partner in the position of stepparent. These may be derived from past experiences in her family of origin, or may be socially constructed.

* ***Cultural/Peer Group***

The cultural domain is the social setting that a woman belongs to and which influence her attitude towards parenting. For example as a mother in a stepfamily she might be part of a group where stepfamilies are fairly common, or she may belong to a group where this is often not the case and where separation is disapproved of. This might particularly be the case for certain more orthodox religious groups. This domain involves many aspects of a woman's attitude to life and her personal philosophy.

* ***Psychological Domain – emotional vulnerabilities and strengths; patterns of attachment***

This domain is the psychological makeup of the mother; her inner world and emotions. It includes such areas as her level of self-esteem, her emotional vulnerability and sensitivity, her maturity – whether or not she has completed early developmental tasks, her needs in relationship, her ability to think of others as separate from herself and her style of relating – whether she seeks closeness or distance, dependence or independence with others. All of this is

influential on her choice of relationships, her ability to sustain relationships, how she relates to her children and partner/s and whether or not she is able to fulfil her own – and others – expectations of herself as a mother.

* ***Circumstantial Domain***

This is about the external circumstances that may be entirely beyond a woman's control. It includes practical level of resources, money, housing, support from others etc. whether or not she is in a relationship, the character of the other parent and partners (fathers and stepfathers) etc.

This way of thinking about mothers relates to Stern's description of mothers. He describes them as becoming *psychically* organised into a constellation of 'spheres' (Stern, 1998). According to him mother is also involved in a network of 'schemas of being with another' which include her infant, her husband and her own mother and father.

The 'domains of influence' model identifies major influences on how stepfamily mothers construct their world. Therefore a therapist might explore each area with an individual, in order to resolve conflicts and paradoxes between the domains and thereby work towards integration.

I spent some time trying to develop this model but began to feel that I was trying to make the data fit the model rather than find out what was within the data.

Furthermore I found that as I started to bring out these themes from the interviews in writing the first one I tackled – the Historical Domain – expanded until it seemed to encompass all the others. The problem was that the domains were so interconnected that it was practically impossible to distinguish domains through extracts from the interviews.

Writing about the domains was my first attempt at putting the interviews together in a thematic form. Eventually I put this idea to one side, although I found it a useful way of thinking about mothers in stepfamilies it seemed too complicated to use as a framework for presentation.

ii) *The Search for a Good Father*

Another earlier hypothesis arose from the data and was not sufficiently backed by material to be presented in full. This was around the relationship women had with their own fathers and their stepfamily story. I considered that this first relationship with a man was key in how they understood and related to men in their lives. It was an influence in how they chose partners, what they expected of their partners as fathers and many other aspects of their relationship with men.

The theory that their fathers have an influence on women's future relationships with men goes back to Freud's Oedipal Complex (Freud, 1911) and has been developed by many other psychological thinkers since then (Reber, 1988; Gomez, 1997). It arose in this case because several participants reported having had difficult relationships with their own fathers. For example Esther described her father as severely disapproving, Bella described her father as distant and not very present, Amanda felt punished by her father for her adolescent sexual forays and a major theme in Elaine's story was of how she deliberately looked for someone very different from her own father, to be father to her children. I considered the possibility that for many women, following the failure of their relationship with the father of their children, a new relationship signified the search for a good father; in effect both for themselves and for their children.

These ideas seemed to be supported within several participants' accounts. It was a theme I might have included in the overall presentation but I did not have enough material to elaborate on it and needed to limit my writing. I felt that these were areas that would benefit from focused research at a future date.

Mothers and Biology in Stepfamily Situations

The themes I eventually chose to present were those that were common to all participants and which highlighted their roles as mothers, how they related to fathers and the issues that occurred in their families. This begins with my summary of their family structures – which showed considerable diversity. Using extracts from their

interviews I show how the mothers viewed themselves as main carers for their children. I contrast what they have to say about mothering with stepmothering as in the majority of cases they had different expectations of themselves as mothers than as stepmothers. I also show the reasons why relationships with fathers ended and the nature of ongoing shared parenting as this illustrates the resilience of biological groups. I conclude that these mothers were central forces within their stepfamilies and biology as a major influence in the nature of their relationships with different family members.

The full interviews from which these themes are taken are included as Appendix VI.

Stepfamily Types

Before looking into how the participants spoke about their experiences as mothers, I consider the structures and types of their stepfamilies. Further details of participants can be found in Appendix I.

I list participants' family structures here according to Ihinger, Tallman and Pasley's nine level typology (Ihinger-Tallman and Pasley, 1987; quoted in Robinson and Smith, 1993). I have not included the whole list, just those that relate to the participants of this study.

- a) The couple have a child in common and one or both have a child from a previous marriage who does not live with the stepfamily.
(Elaine, Robin's first relationship Esther's first relationship, Clody's second relationship)
- b) There is no child in common, but one or both have children of a previous partnership who do not live in the family and may or may not visit the stepfamily. (Leanne at the start of her second relationship, Esther's current relationship, myself in my second relationship).
- c) At least one had a child from a previous relationship who now lives with them. (Barbara, Claire later on in her relationship, Mary, Leanne later on in

her relationship, Robin's first relationship, Robin's second relationship, Sally)²⁰.

- d) Both have a child or children from a previous relationship now living with them. (Leanne later on in her relationship).
- e) Both have a child or children from a previous relationship, at least one of whom lives with them, while others reside elsewhere, plus a child in common. (Bella's second relationship, Clody).

Five out of Ihinger et al.'s nine categories (as quoted in Robinson and Smith 1993) were represented in my close sample of eleven women although these categories do not cover all eventualities (see footnote 12). The variety of structures within the families of this close sample of women is striking. This finding is consistent with research which shows that there is a huge diversity of stepfamily structures in the general population (Robinson and Smith, 1993; Stewart, 2007; Coleman, Troilo et al., 2008)²¹.

Participants' stepfamily structures were often transient so that over time a mother might have lived with her children in several different situations. Seven out of eleven women described their families as having fluid boundaries and changing household memberships.

Some of the changes that took place in participant's families were as follows:

- * In my own family; my stepson lived with his mother for the first five years of my relationship with his father and then moved to live full time with us.

²⁰ The list provided by Robinson and Smith contains no category for couples who have a child in common, and at least one has a child from a previous relationship, with all children living in their household as was Sally's situation. I have placed her here as this is the closest descriptor of her family. It is unclear whether or not the omission of this category is a misquote.

²¹ Amanda did not fit any of these categories. She was a single mother whose ex-husband had a new wife so that her children had a stepmother. Single mothers like Amanda are not usually included as part of a stepfamily because of stepfamily definitions being focused around households (Mignot, 2008) however I have included her in the sample as she was dealing with stepfamily issues, from a perspective that is usually overlooked

- * Robin started off living with her stepsons before having her own children; her second partner had no children of his own.
- * One of Leanne's stepsons came to live with her when he was sixteen.
- * In Clody's stepfamily one stepchild moved from living with her to living with his mother. For the first few years she and her partner had no child between them and later on one child.
- * Bella's second relationship started off with her having one child and her partner having a daughter who lived elsewhere. Her third relationship was with a man who had no children and her current relationship is with a man who has two adult children.
- * Esther had two stepchildren before she had her own child in her first relationship, she then had two stepchildren in her second relationship and two further stepchildren in her current relationship.
- * Amanda's children lived with her as a single mother, full time with their father and stepmother for two years and then returned to live with their mother²².

Within these participant's households different memberships were the result of: parents living in separate places; children moving from one parent to another's household on short or long term bases; the ending of a relationship, of new children being born and the forming of new partnerships with or without the involvement of stepchildren. (In general stepchildren accompanied their parents in and out of their relationships).

These findings indicate the potential for a stepfamily to transform in shape and to have complicated boundaries. This has been noted in the wider field where, according to Hawker and Crowe's analysis of family change in Britain (Allan,

²²Household changes are illustrated in Biogram form in Appendix I on page 245.

Hawker et al., 2004) ‘the realm of family practices have become more blurred (and that) for many, the whole complex of family/household activities now crosses household boundaries’.

More than One Mother

Characteristically, most stepfamily households are linked to other single or family households. There will always be another mother or father external to the stepfamily household (unless they have died), therefore some stepfamily situations contain two or more mothers. Taking my own family as an example I have two children and my husband has one. Therefore there are two mothers involved i.e. me and my stepson’s mother. If I expand the family boundary to include my ex-husband’s second partner (now ex) then the situation contains three mothers²³. I have included these in the chart below (Figure 9).

Several participants referred to relationships between mothers, some of which were inclusive and others that were difficult (see discussion starting on page 450). It seems that where the mothers were able to communicate well the families had the potential for becoming what I call a ‘stepfamily community’. i.e. a large family group, connected through the parents, rather like a version of the extended nuclear family. These extended stepfamily groups seem stable with different members relating well across households. An interesting example of this among the participants was with Robin and Barbara (see pages 143 and 275).

Conclusion

These findings show that stepfamilies have individual characteristics and histories as represented by the variety of participants’ families structures. Many participants’ families did not look like nuclear families in that they had parents living in different houses and changing memberships. The whole family network often contained several mothers, fathers and children and a mixture of biological and non-biological relationships. Thus, they could be seen as an alternative form of extended family.

²³ There can also be found three fathers, my ex-partner, my husband and his second partner’s ex-husband. A further extension could be made to include my stepson’s mother’s other partners. As she had four children each with different fathers and now has a relationship with a man who has a daughter of his own, the situation could be said to include six fathers.

Name	No. of Children	No. of Stepchildren	No. of ex-partners	Children with current partner	Type of Family (x signifies type of family)				No. of Parents in Stepfamily Group		Children at home
					Smother	Sfath	Both Steps	Single parent	Mothers	Fathers	
	<i>P=partner. Partners are labelled numerically, alongside the number of children within that relationship.</i>										
Amanda	2		1	N/A			X	1	1	0	
Barbara	2	4	1	0			X	3	2 (1) died	0	
Bella	P1-1 P2-2	0	3	0			X	P2-2 P3-2	P2-1 P3-2 (1)	0	
Claire	2	1	1	0			X	2	2	0	
Clody	2	3	2	N/A			X	2	2	0	
Elaine	1	2	0	0	X			2	1	1	
Esther	1	P1-2 P2-2	2	0			X	P1-2 P2-2	P1-1 P2-2	0	
Leanne	2	2	0	0			X	3	1	0	
Mary	3	0	0	2				1	2	1	
Robin	2	P1-2	0	0		X		P1-2 P2-3	1	0	
Sally	P1-2 P2-2	0	0	2		X		2	2	3	

Figure 9 - Chart of participants

Becoming and Being a Mother

Here I look at what mothering meant for participants irrespective of their family context. Several participants spontaneously described the period when they first became a mother, when they were living with their child's father and involved in an intensely close relationship with their baby. It seems that the importance of this period to these mothers was that it provided a context for how they related to their children.

The Minute Children were Born

Nine of the women interviewed including myself described what happened to them either when their child was born or in the early years of their child's life. Each woman expressed a different set of feelings in relation to their child. These feelings were strong and immediate. One who had complications during pregnancy suffered with post natal depression; she had an initial negative response to her baby and becoming a mother.

From the minute they were born I took full responsibility. Like they were to do with me, they were mine. I'm saying that "they're mine" is the feeling I had from the minute they were there somehow. It's like something kicked in when they were born. (Claire)

The minute they are born they gain independence and you are losing them in a sense. That's how it feels for me. Being a mother is like one long experience of loss. You just lose them. (Esther)
They don't actually need anyone but you in those early months and that's extremely intense. In the early years they feel a bit like you. My memory of the first couple of years is of this very intense physical experience of attending to his physical need, the breast-feeding, the cuddles, the intimacy. (Elaine)

I felt it was an incredible responsibility to be a parent – or to be a mother. That came first. It wasn't a burden it was like the main... (Bella)

I'd never held a baby till I held Andy literally. I didn't know what to do. I was just overwhelmed by this whole mothering thing.

(Clody)

I just entered this bubble of being in love with this baby, and she was such an easy baby. (Robin)

Responses were different for each mother but were in every case described as immediate upon the arrival of their baby. An example of instant change can be seen in Sally's account of her concern for personal freedom disappearing when her baby was born.

I remember the minute she was born I was quite keen on getting remarried. There was something about wanting this sort of security, just feeling a lot of love; I mean a lot of strong feelings when she was born, towards her, and us as a couple wanting to look after her. When she was born there wasn't much point in worrying about that I was losing my freedom because I had lost it.

(Sally)

These women's accounts are of what it feels like to be a mother at the beginning of their child's life. Each described a unique relationship with her baby that involved strong feelings and responses. It seems that with the birth of their child the women were transformed and she became a mother and baby couple (Winnicott, 1986) with her baby existing outside of her in a dependent state.

What a Mother Expects of Herself – Mothering Tasks

Many participants talked about qualities and tasks connected with motherhood.

These were focused around looking after and caring for children.

Several mothers talked as if they knew what was expected of them as mothers and seemed to have a clear picture of what they understood to constitute good mothering. Much of this was expressed as self-criticism. Amanda for example felt that a mother should be intuitive and empathic, responding to her children's needs and ensuring they were cared for adequately in a nurturing environment.

I followed my own instincts and I think it did something for me, realising that I must have had a bond with Tom in order to know that he was in danger.

I wasn't very tactile and I wasn't very warm. I didn't 'want out' from children but I wanted to be able to live, I wanted to have a life and do something that I wanted. So I wasn't feeling very sensitive to the children.

I wasn't the best mother, I was definitely neglecting them in some way, but I did have an au pair, I paid the au pairs and I made sure they were good people so they did have somebody nice and loving and caring with them. (Amanda)

Other self-criticisms were equally specific. Barbara said unlike other mothers she was not firm enough to be consistent.

I've met people you know, they have a rule and that's the rule and you stick to it, whereas I always found that you make the rule and then the rule would kind of slide and slip and once you've done that the kids know they can get round you. It kind of depends on what sort of mood you're in rather than being able to say 'well that's the rule OK, just do it'. And I was never any good at that. (Barbara)

Elaine described various mothering tasks and qualities, including being communicative, being in the home, involved in child focused activities and playing with them, and relating to other mothers. Another area of tasks she saw as belonging specifically to mothers was in the area of practical care: providing for physical needs, and creating a good home environment by ensuring regular routines, nourishing food, physical safety, welcoming atmosphere and so forth. A good mother would be adequate in all these areas, whereas she was often out of the home and did not get involved in imaginative play.

If I'd been a stay-at-home mum I would have been suicidally depressed. I would have liked to be less frantic and have more

time and not be driven by the need to pay the mortgage, but I could never have been somebody who organised the school fete. I'm just hopeless at things like that.

I was never very good at playing mummy in the sense that I couldn't really stand all the hours and hours and hours of building lego castles and making musical instruments out of used yohourt pots. ... I'm good on illness and I can keep children safe, and I know how to give them a reasonable diet but I wasn't by any means the world's most inspired child minder.

I don't think I was very good at playing for hours doing the same thing. I think there were loads of things that I wasn't terribly good at. He had the normal things, like proper food, proper bedtimes and he learnt to swim and to ride a bike and he knew his friends were always welcome here. But my mother was just incredibly selfless and I wasn't like that, and she did it more or less without complaint. (Elaine)

Similarly to Elaine, I felt that a mother should be constantly available to her children and should put their needs before her own. That she should be at home and not too interested in activities that took her away from caring for them.

What I find hardest to come to terms with about myself as a mother was that I was never really able to give myself to them (my children). They weren't going to stop me from doing what I wanted to do, and I'm sure they suffered from that, although they never told that to me. I wasn't in some ways very good and maybe quite confusing because I'd be warm, and I'd do parties and I'd be generous but I wasn't going to put them before me in any way and I wasn't going to put them before my relationship, but I was in conflict about it. It wasn't like I was all awful, I was there, I made sure they went to school and they were clothed and fed and I was aware of them, but I still feel bad about that. I suppose I think that a mother should give more to her kids than I did. (Claire)

These mothers seemed to be relating to ‘the myth of motherhood’ in which ‘*the good mother*’ is characterised by her natural ability to nurture and her unique pleasure in sacrificing her well-being, if necessary for the good of the child (Braverman, 1989; quoted in Coleman, Troilo et al., 2008, author's italics).

I saw mother’s self criticism as referring to another powerful image that of the *bad* mother. Most of the mothers I interviewed felt that they had been bad mothers, or had not lived up to what was required of a good mother, at those times when they did not personally fulfil those aspects of relating to children which demanded that they be present in the home and attentive.

These findings were supported by Lawler, who studied mothers and daughter’s relationships, found in her analysis that the women she interviewed were saying that mothering ‘*means* meeting children’s needs’. Children’s needs and especially their emotional needs, are the *point* of motherhood. What mothers are there for is to ‘fulfil’ [children’s] needs. The extent to which they do this successfully is the measure of good (or bad) mothering. (Lawler, 2000, p125, author's italics and brackets).

Mothers as Stepmothers

In those families where participants’ partners had children from a previous relationship, mothers were also stepmothers. This was the situation for six participants including myself. These women talked about how they perceived their roles and responsibilities as stepparents and how they related to their stepchildren’s mother (their partner’s ex-partner).

Stepmothering

Participants described having a different relationship with stepchildren than with their own children and their role as stepmother as differing from that of parent. Parents (i.e. mothers and fathers) were seen to be responsible for children while stepmothers supported their partners in a less involved manner. These women appeared to be describing a hierarchy of inclusiveness and closeness where children

were closer than stepchildren and parents than stepparents, while family members (including stepchildren) were closer than other people.

Living Arrangements

All the stepchildren described in this study lived primarily with their mothers, although several spent protracted periods when they lived full time with their father and stepmother. Stepchildren were usually several years old when they met their stepmothers and started off as part time members of their household.

The boys weren't there all the time, it was most weekends and quite a lot of the holidays, but I did feel that they were the priority; that we needed to fall around them. (Elaine)

We had the boys weekends and school holidays. (Robin)

Gary worked very long hours and we had the boys at weekends. (Esther)

The resources needed for looking after children such as time, space or money, were not mentioned by any women in relation to their biological children even if these might have been in short supply. However three women described their stepchildren as stretching their available resources. This gave me the impression that despite stepchildren being liked and accepted they were perceived by these mothers as being were in some way *extra* to their household.

I was always falling over them or their piles of stuff. I could have done with more space and more money; financially we were very very strapped. (Elaine)

Often he was working the weekends he had the kids so I would end up looking after them in the daytime as well as mine. I've said to him 'that was madness, what should have been happening is that you should have been having all the kids, my kids as well for the weekend, because I was having to deal with them all the time. (Barbara)

Gary would go over there a lot....he would baby-sit three times a week and he'd just be on call really.

He carried on being the husband and the dad in the sense that if something broke or something he'd kind of go there (Esther – early on in her first relationship).

The existence of stepchildren and their entitlement to a relationship with their father was accepted by and supported by these mothers. What seemed difficult was the diversion of resources towards them. These stepchildren seemed to be being experienced as requiring attention and resources in addition to those that already existed. They filled space, needed attention from the stepmothers or drew their father away from the home he shared with her.

Stepmother's Tasks

Most of the mothers felt that they were not responsible for decisions regarding their stepchildren, they saw this as the job of their parents. They were however involved with their stepchildren's physical care as their stepchildren were part time members of their households. Two women used the word 'nurturing' to describe what they were doing.

He didn't have a proper home so when he had the kids they would come to my home and that made me feel very stepparenty. I would want them to feel at home. I do love nurturing, so I would be really pleased that they were coming and do all the kind of nurturing, mothering things with them (Esther).

I took on a fairly nurturing role with the boys when I was twenty one (Robin).

I suppose I did all the practical things, you know having to peel twice as many potatoes (Leanne).

When Richard came to live with us I was buying the school uniform, making packed lunches and all that kind of stuff. But I was training to be a nurse so I wasn't always around at weekends or in the evenings. They did as much with their father without me as they did with (Robin).

Thus in their position as stepmother these participant's provided practical caring for children i.e. cooking, shopping and child minding. They described being kind and thoughtful in doing what was needed for their stepchildren and enjoying these tasks. There were several examples of stepmothers being concerned for and loving of their stepchildren but no participant described feeling primarily *responsible* for looking after her stepchildren's emotional or physical needs.

Feelings Towards Stepchildren

Four women described relationships with their stepchildren as being less connected and intimate than those with their own children.

I always saw them (stepsons) as very different to me. In that sense you are very bound up with your own child whereas my stepsons were always different individuals. They were always very polite and reserved. Quite rightly they had their boundaries. (Elaine)

My own perception was that my stepson wouldn't have wanted me close to him as well as that I didn't feel close. I did motherly things for my stepson but he wouldn't have wanted me physically close to him for example. (Claire)

If they'd been my own children I wouldn't have wanted to embark on three and a half years of back to back shift work and stuff. When you've got your own child there's something about wanting to spend as much time with them as possible. (Robin)

I can't imagine being fonder of a stepchild than I am of my own blood children, but we've rubbed along alright. (Leanne)

These relationships with stepchildren seemed more distant and less involved than those with children. Thus these women were describing them as having a different and more separate quality than those with biological children.

Esther had one son and three sets of stepchildren through three different partnerships. While she described loving and enjoying her stepchildren, her reactions in relation to her son suggested an emotionally involved relationship with him that was less present in her feelings towards the other children. She found that her feelings towards her stepchildren became more connected as time passed.

I've had stepchildren all my life. Talking about the stepchildren bit is fine, its talking about my son that brings the tears up (Esther).

As my stepsons grew older I just grew to love them and also feel very proud of them (Esther on stepchildren from first relationship).

Esther especially appreciated having stepdaughters. In her current relationship she has two.

Henry had a daughter which of course was lovely for me (Esther on stepdaughter from second relationship).

Because I never had a daughter it was lovely to have her in my life. It was such an affirmation to have this other female and I am sure it was the same to her. We bound together against John. So we had this great bond that developed between us, defending each other and supporting each other when we were hurt or when John was being annoying (Esther on Lily - stepdaughter in current relationship).

She reminds me of me much more than any of the other children. She's just a wonderful little girl. I think she's just fabulous. She's just brilliant (Esther on Leila – stepdaughter in current relationship).

Thus it seems that for Esther who had an only son, stepchildren were an opportunity to develop close relationships with other children. As such they were a bonus and her enjoyment of them, especially of the girls, was evident.

Overall the difference between how the women felt towards their stepchildren compared with their own children was that there seemed to be more separation and less intense emotional involvement – a sense of people getting to know each other,

rather than belonging to each other. This meant that as stepmothers there was the potential of being a supportive adult or mentor without the complications of the more identified and enmeshed aspects of the mothering role

Hierarchy of Relationships

Participants described their family relationships as a hierarchy of inclusiveness or closeness. The way this worked was that usually their own children came first followed by their partner and his children. Parents were perceived as having special responsibility for their children, including parents who lived outside their stepfamily household.

Non-resident parents were sometimes mentioned as being part of the family group. Most notably this was the case in Barbara and Robin's families, who were connected through Barbara's current partner Andy, Robin's ex-partner. Barbara has two children from her previous relationship and she and Andy have no children between them. Andy has two children with Robin and two from his first relationship, all of whom are therefore Barbara's stepchildren. Robin's partner has no children of his own. This entire family group acted as an extended stepfamily group of children, stepchildren, half-brothers and sisters and three different mothers, with Andy as the person who connected them all. They met together as a whole family at special occasions such as Birthdays and Christmas.

A similar family group was described by Leanne who included the mother of one of her stepsons at all family gatherings. She described her children as closer than her stepchildren and both children and stepchildren as closer than the world outside her stepfamily.

I had more sympathy with my children than Phil's children, I mean if it came to the crunch..... But then if we were out anywhere with kids that were more distant from the four of them, then they would instantly be taken into the fold. They were more my kids than the other kids'

When it came to stepparenting most of the women saw themselves as secondary to mothers. Three of the women described their stepchildren's mother and father i.e.

their partner and his ex partner, making decisions between them in regard to their children. These women did not seem to feel that they should be part of that.

I didn't want to butt in between John and Janet. I mean they had made the arrangements and I didn't feel it was my place to go against what they had decided. (Leanne)

I never dealt with his children. They were around at holidays and weekends but I didn't ever feel that I had any say over what they were doing. That was fair. (Barbara)

These comments could be interpreted to suggest that the mothers accepted their stepchildren's parents as having primary roles and primary responsibilities. In contrast they viewed themselves as having fewer rights and responsibilities over their stepchildren than biological mothers and fathers did.

A contributing factor to Esther's sense that her stepchildren came first was her feeling that she had taken their father away from them and their mother.

I felt very guilty and so I felt that I had no rights in the situation even when I was pregnant. Even during my pregnancy I felt that they were the priority and they were the most important. So that was very difficult. (Esther)

Clody imagined that she and her second husband would be able to be substitute biological parents for each other's children. She did not want to include either her own ex-partner or her stepchildren's mother in her new family²⁴.

I wanted to have this cohesive little family. This new family with no distractions and me making lentil pie for everybody. I wanted somebody to be a dad for the boys and what happened was the the stepchildren lost out having me as a mum because I wouldn't

²⁴ Clody's family fits Levin's description of a 'reconstructor' stepfamily which tries to recreate a nuclear family with the stepmother taking the place of a biological mother (Coleman, Troilo et. Al. (2008).

give enough of myself. I felt it was kind of rationed. I thought 'I'm not going to do it because I've got to give double to these boys because they haven't got a dad, and there's nothing left for them. (Clody)

Thus Clody during this period seemed to disregard an order of closeness that other stepmothers accepted and adhered to. This was not a happy situation for Clody who felt that she was becoming 'a wicked stepmother' in relation to her stepchildren when she felt unable to love them.

In contrast Elaine did not expect to be her stepson's mother.

You have to find a way to establish a relationship in the first place in a very different way. It's all about being friendly but not suffocating. I set certain rules for myself from the beginning. I wouldn't expect them (the boys) to like me; I would try and support John in his role as a parent. Rather than trying to act as a mother I will try to be a friend to the boys and just get on with them in a sort of undramatic and unforced way (Elaine).

In this statement Elaine identified her place as stepmother. In so doing she corresponded to the category of 'friendship' in a list of stepparent styles identified by Erera-Wetherby. These were '...women who genuinely accepted and cared about their stepchildren but did not try to act like the children's mother' (Erera-Weatherly, 1996; quoted in Coleman, Troilo et al., 2008, p378).

Other Mothers – Partners' Ex-partners

In those families where participants were both mother and stepmother, their stepchildren's mother (their partner's ex-partner) was an external influence on their household. The quality of the relationship between these two mothers was not always easy especially when ex-partners were not amicable.

His relationship with his ex-partner fluctuated, so there were times when it was okay and she would want him there a lot and was fine with me being there, and there were other times when it was more difficult and she didn't want to see me (Esther).

I don't know Marge well at all. I've met her a dozen times I suppose. I don't know what happened with her and Phil when they split up.....She was very backed off and sort of 'don't come too close'. Yeah she's always been a bit of a mystery woman (Leanne).

I didn't particularly like what I learnt of Eileen, but it's a bit unfair because I've never actually met her. All these years later, I've never met her. John and she have never got on to a reasonable footing. They've never been out for a drink together; it's been a complete divorce (Elaine).

These three women attributed the distant nature of their relationship with the external mother to her (the external mother's) relationship with the father of her children - her ex-partner.

There were several other influences on the stepmother/mother relationship. These included the opinion of the stepmother on the character and mothering qualities of the external mother and how available the external mother was in relation to the stepmother.

The reason I haven't said very much about David and Richard's mother is that I've got very little time for her really. When they were small she worked as a musician..... I felt that she neglected the children when they were growing up.... I found her egotistical and self centred (Robin).

He led me to believe that his ex-wife didn't want the children, so for twenty years I was angry with her thinking 'how can this woman have left her children and I'm looking after them' (Clody).

Conversely, Leanne perceived one of her stepsons' mothers to be a good mother and important to her son: this encouraged Leanne to include her as part of the family. (She had two stepsons, each with a different mother).

She's always been totally into doing the best for Jack and I've gone along with that, making it possible for her to join our family. She's quite brusque, not the easiest woman to get on with, and I

felt that if we weren't going to be her family then she would feel very bereft when Jack left. I've always tried to make her welcome and include her in; so if Phil's mum is coming to Sunday lunch or something then I'll pass out an invitation to her as well.

Some stepmothers described providing compensatory parenting if they perceived a lack from either parent. In these instances they might be seen as 'stepping up' from their role into that of a substitute parent.

The fact that Richard chose to come and live with us was because he got things living with Andy and I that he didn't get living with his mother, which was some sense of safety and continuity and regular meal times and so forth (Robin).

We would have those conversations which I am sure she wanted to have with Gary, because you want to share those things with somebody (Esther).

She had a very difficult relationship with her mum, so there was quite a lot of room for me to be nurturing and do all those kind of nurturing things (Esther).

These descriptions seem to be of stepmothers filling gaps in parenting tasks that parents were not doing.

The potential for a stepfamily to become an alternative to the extended biological family was described by Barbara.

We used to have this thing where he would go up to see his kids at Christmas and I would have it here, and I thought, "this is a bit silly" and so I said "well why don't we invite Robin here for Christmas and the kids and we'll have one big Christmas?" I think the first one we did we had Robin and her kids and his first wife. I used to go back to work after Christmas and everybody would say "did you have a good Christmas?" and I'd say "yeah, we had round both his ex wives". They said "What?". And to be honest I

don't think he's ever quite realised how lucky he has been that everybody has been able to get on because not many people would have been able to do that.

In this situation, all the mothers in the family were included, and the different parts of the stepfamily were brought together in a large group of diverse relationships.

Overall participants described various types of relationship between stepmother and mother, some more distant than others. There were several contributing factors to this, including the relationship between mother and father, and how the mother was perceived by the stepmother. The quality of the relationship between stepmothers and mothers influenced the integrity of the stepfamily group in a spectrum of inclusiveness. At one end of this spectrum families were divided and the stepfamily household isolated – as in the case of Clody, and at the other end the stepfamily became an ‘alternative’ extended family, with different groups of parents and children connected through the stepfamily situation as seen in Barbara and Robin’s families.

Current Relationships with Stepchildren

I now consider how relationships with stepchildren have developed with time; what was the outcome of the stepmothering relationship. Four women including myself commented on this. Each one included their stepchildren when talking about their family and overall had good feelings about stepmothering and of their stepchildren.

I feel privileged, not just having had my own son but also the stepsons. I would have liked more children but that didn't work out. I feel I got given the chance to have other relationships with children and I've been very lucky in that I think. Among my close friends I'm the only stepparent. I think very positively about it.
(Elaine)

Maybe it was because I'd had an enjoyable time stepparenting. If stepparenting had been a nightmare its interesting to speculate whether that would have put me off having my own children, isn't it? (Robin)

I can't imagine Jack and Ben drifting away and me never seeing them again. It's beyond comprehension. Maybe it's because I've been through it and we've got to a stage where they're making lives for themselves and all the logistics, and upheavals and the schooling and adolescent angst and stuff is all behind us. I don't know if it's different for people who are still going through this sort of stuff. They could feel that these people could disappear and they'd never be seen again. (Leanne)

I'm really fond of my stepson. I don't feel his mine, but he's definitely part of my family. (Claire)

Three other mothers had separated from their stepchildren's father. Of these, two had a continuing relationship with their stepchildren and one – Esther – lost contact with her stepchildren although she remained interested in what they were doing. Of the two who had stayed in touch, one was Robin (described earlier) who had a good relationship with her ex-partner Andy and his new partner Barbara. The other Clody had only recently separated from her husband – her stepchildren's father.

I've got these wonderful children I'm very very close to and I feel regret because there was time wasted; all the time wasted rowing and worrying and being sad and being angry. What a pity; all that energy could have gone into doing good stuff. It's such a waste (Clody).

Esther described having fond feelings for her stepchildren but no support for staying in touch, or a family forum where they might naturally meet after her relationship with their father ended.

These children that you've become part of, that you've grown to love, it's an awful thing that you lose them, your stepchildren. I don't feel banished from their lives and their world; it's just that they are getting on with their lives and because of what's happened there is no facilitation of us seeing each other; those family occasions where you would see the young people that have

grown up. They went to university and moved away so there's not really an opportunity to see them. (Esther)

It seems that time was a factor in bringing stepparents and stepchildren closer. However when relationships with parents came to an end, it was likely that relationships with stepchildren would become more distant. Stepchildren seemed to be more attached to their parents than their stepparents, especially when they were young.

Factors that affected whether or not contact continued between stepmothers and stepchildren included the quality of relationship between ex-partners, age of stepchildren when the separation happened and length of time that they had been part of the stepmothers' family. Thus Esther (described above), lost contact with her first partner's children after their relationship ended, when they were still at school age. However Robin, who was on friendly terms with her ex-partner Andy and his new partner, continued to be in touch with his children – her stepchildren and Clody whose stepchildren were adult when she and their father separated also continued to have a relationship with them.

All the mothers who were currently stepmothers were appreciative of their stepchildren and valued them as important family members.

The Cause of Family Breakdown – and the Aftermath

I now look at the reasons participants gave for separating from the fathers of their children in the first instance.

Marjorie Smith writes that 'mothers are the cause of the stepfamily to the extent that they have entered into a relationship with a new partner, and the childrencome as an adjunct to this relationship' (Smith, 2008). In saying this she puts a lot of weight on the mother as regards stepfamily causes and there are other possibilities. For example a stepfamily might be caused by the man entering a new relationship with the mother as non-resident parent.

All the women I interviewed (except for Mary who was pregnant with another man's child when she entered her new relationship) began their mothering either living with or married to the father of their child. It was the break-up of that original family which resulted in the mother's family becoming a stepfamily. The majority of separations were instigated by the participants in that they left their partners. There was a strong theme of this being the result of fathers being unable to manage an equal parenting role with the mothers, or being unwilling to do so. Thus there were four instances in which the mother forced the separation because of unreasonable behaviour from the father. This ranged from violence towards the participant, drug use and alcoholism, to competing with his children for attention. In these cases it was difficult for the mothers to end the relationship, and they spent a period of time trying to make the situation work, before making what might appear to be a sudden decision. In one instance it could not be clearly said who had caused the separation as the relationship had broken and both parties had contributed to the situation. Two other women were left by their partners.

Mother's Instigation

Five women including myself were the ones who instigated separation from the father of their children. Three did so because the father was violent or alcoholic. These women described a range of feelings in response to their circumstances which included being overwhelmed, threatened and self-blaming for making a bad choice. Each of these three women continued in their relationship until they reached a point where they felt they were forced to make a choice. In each case this was a sudden decision based on the need for self-survival.

It was an impossible situation. It was like I'd given up my own power and I was just doing whatever happened to be happening at that time without real thought. I was just dealing with things and trying to keep Johanna's life as normal as possible.....I felt I had to get out for my own identity; to keep myself intact. (Bella)

Things weren't bad all the time but they were quite unnerving and there was alcohol involved and a lot of other things, low self

esteem.....After a few years I thought 'I can't do this any more I'm getting a bit scared' and although he was never ever violent to the children or around them I just felt nerve wracked all the time and I couldn't. (Clody)

I had this awful partner who was an alcoholic. I should never have had children with him, he was an alcoholic before I had the children. If I saw somebody doing it now I'd say 'why are you so stupid? Why would you?' I'd say if I'd lined up every man suitable for father material he would come at the bottom this list. He was completely unsuitable father material.....If you are really soft and forgiving and keep on putting up with shit they (your partner) think that's going to continue for ever. I couldn't see a way out actually. I finally snapped when my daughter was 18 months old (Barbara).

For these women leaving or forcing an ending was something they felt was necessary rather than a choice made for less urgent reasons. It might be said that the behaviour of the fathers made sustaining the relationships unviable.

Three other women separated from the father of their children after their relationship had broken down in less extreme circumstances. In these cases there was a sense of the woman's agency in choosing to leave an unsatisfactory relationship. Amanda in her marriage and Bella in her second partnership both described these relationships deteriorating. Both women maintained mothering roles while the father became increasingly involved in his work. In both cases this led to increased distance between the couple, collapse of sexual relations and eventual separation.

I'd be rushing around in the morning with the two babies getting food together because he wasn't going to. And then if I didn't make him sandwiches or something or other to take for the evening meal, at work he wouldn't take any. And then he'd complain because he had a delicate stomach. I've got two babies, they take up this much time, you're gonna have to take a step back as far as our relationship goes, you know as far as time with each other goes, because I've got these two babies to deal with..... He was another responsibility. (Bella)

It'd got to the point where we'd talked about just staying together for the children because we still got along as friends, but our sex life had finished and that was because of me. I just couldn't cope with having sex with him any more. I just wanted to be left alone, so I left. (Bella, talking about the father of her sons)

In terms of the break up of the marriage it wasn't characterised by much animosity and there were no other people involved. When we separated it was really because I felt the relationship was over. It was my choice to separate and I didn't have any particular animosity towards him. (Robin)

We were living more and more apart, he had his business world and I had my home life. I was sure he was having affairs but it wasn't until the day that we decided to divorce that he told me. We had rows all the time. We tried and eventually decided to split up. I wanted a separation and time. He said 'I want to know if we're ever going to get back together' and I said 'I don't know' and he said 'if you can't say that's a possibility then I want a divorce'. (Amanda)

Overall, among this group of participants, the most common reason for separation was their unwillingness to continue enduring irresponsible and/or dangerous behaviour of the father. Three women in extreme circumstances were not easily able to protect themselves and their children within their relationship and therefore brought it to an end. These women were driven to act in order to survive, rather than because they felt they had choice in the matter.

In contrast Robin's decision to separate from her husband when she felt that her relationship was over, seemed considered and measured

Mothers left by Fathers

Two fathers left the participants when their children were under five years old and the youngest child was still very dependent. Neither of these fathers prepared the women for their intended departure and both left the mothers with the children.

*He said he was off to **** to see his mates, give him a bit of head space and sort things out in his mind and then he'd be back.....and I had a phone call from Linda's mother who said 'when are Linda and Andrew getting back from ****?' I said 'this is the first I've heard of this and it suddenly occurred to me 'hang on Gloria' and I went off to the drawer where the chequebook was kept, opened the drawer and it was gone. I instantly knew what had happened; knew he'd done a moonlight. (Leanne)*

He was meant to be working away three days a week, spending two days working locally and seeing more of the family after Ben had been born. He didn't seem that interested in Ben. The day he left we had a row about Ben's birthday. I'd asked 'are you going to be around for Ben's birthday?' and he said 'Oh yes I am definitely' and then at the last minute he arranged a business breakfast in London and we had this massive row about it. He went off that morning and said he wasn't coming home. So it was quite sudden. (Sally)

For both these mothers the father's departure was an unexpected event and a unilateral decision on his part.

The fact that most of the causes of stepfamilies were mothers who were unable to share parenting satisfactorily with fathers, suggests that fathers, not mothers were the cause. However, the mothers acted in self-protective ways and in so doing also protected their children, thereby being pro-active in ending their partnership.

Single Parenthood

I have included the theme of single parenting as it was striking that all eight participants who spent a period of time living with their children as a single mother (as did I), described this as better than being in a difficult relationship. All but one of these mothers described different liberating aspects of single parenthood.

It was easier being on my own than being in what was really a bad marriage. It was much easier, I was free on my own. (Claire)

When I finally kicked him out it was kind of a relief to be a single parent because I didn't have this other thing to do. (Barbara)

It's hard bringing up kids on your own, but I can't help feeling it's even harder to bring up two kids and a grown up child. (Leanne)

I'd always felt in part compelled to marry Rory and then to support him emotionally throughout his work crises. I felt in part that I'd been playing this role and that the reason he couldn't cope with children was because he couldn't be a child with me any longer. I was now free of that and part of me was terribly excited. Even though I had the children I managed to proceed with some things that had interested me for years. (Sally)

Thus each woman describes the relationship they had left as restrictive or burdensome in some way and that living on their own freed them from this. This was the case for all the women, whether or not they had been the ones to end the relationship.

Three mothers talked of advantages of single parenthood. One mother enjoyed a closer relationship with her children and two others found that they had time to themselves when their children were staying with their father.

I had a lovely time when I was on my own with the boys, absolutely lovely. We lived in several different places and I ended up living in a housing association brand new house, and it was just the most wonderful part of town. The boys seemed very happy. (Clody)

It's interesting when you share your children with an old custodial ex-partner, because you're very used to letting your children go and be without you and be on holiday or whatever. But it also means that you have time and space and leisure to yourself as well. (Robin)

When Rory did get a flat in the autumn he had the children for weekends. I was worried about that because they did seem to find it disruptive, but it did mean that I had all weekend without anybody around and I quite enjoyed that. I hadn't had that sort of freedom for years it felt like. (Sally)

I let him have them to stay for a Saturday night and I went out to a party. (Barbara)

These women were describing having time when they could do things they wanted to do, without having to be involved in mothering tasks. Single motherhood therefore had the potential of being a time of relative freedom and autonomy. The situation where the father was living elsewhere and the children spent time with him allowed the women to have a break from mothering and become involved in other pursuits.

Maintaining Contact with Father

As described in the previous section, the relative freedom of living as a single parent was partly due to the father sharing some of the parenting. Most of the fathers maintained contact with their children often with arrangements where their children stayed with them on weekends or on holidays. Robin describes a typical arrangement.

He carried on having a lot of contact with the kids. I mean he maintained them financially, but also had them lots of weekends and school holidays. He'd also come up and visit them sometimes in my flat. So that was pretty easy really. (Robin)

In many cases this contact was facilitated by the mothers.

After my first marriage broke down I was trying to maintain and nurture the relationship that Andy had with his daughters. I don't mean for a minute that if I hadn't done that he would have walked away, but I was very keen to try and ensure for the girls that although they weren't living full-time with their father that he still played a full part in their lives. (Robin)

I let him continue to have access to the children which a lot of women wouldn't have done because there were several situations where really he put the children in severe mortal danger. I did it I suppose for my son's sake, but he could be quite upsetting because he could either just not turn up when he was supposed to or turn up so drunk that I wouldn't let him take them. But I think the kids are quite pleased they did have that relationship with their father. I always thought that otherwise they could build him up to be some heroic figure. (Barbara)

Andrew went away for a year and he came back he got a house and was able to have the boys for the odd weekend. He wasn't very good at that and it was basically down to me to get the boys to see their father. He did things like promise he'd take them out to a firework display and then not turn up. (Leanne)
He didn't seem very interested in staying in touch with them. He met with me only about two or three weeks after he'd left and he said he wasn't interested in the children. But he said his friends told him he'd regret it if he didn't see them and that he was going to see them. (Sally)

Thus the fathers once separated varied in their level of interest in keeping contact with their children ranging from very involved to fairly uninterested.

Two fathers lost contact with the mothers and their children entirely. The stories of the two relationships between these fathers and their children are in contrast with each other. In the first instance, Johanna who had spent a period of time as a child being cared for by her father, re-established a connection with him when she was older. (Johanna was Bella's daughter and her story is contained within Bella's monologue on page 108).

He decided that he was going to leave the area and that he wasn't going to have any contact with Johanna (daughter). He didn't want to be a part-time father, either it was all of nothing. So he left and he left our lives completely. I never saw him again after that. Johanna went searching for him when she was twenty one and

managed to track him down. I don't know if he decided he wanted a relationship, but they started talking to each other on the phone.
(Bella)

In the second instance Mary's daughter Grace had never known her biological father and didn't want to make a connection, but it was her mother who thought it was important to do so.

As far as she (my daughter) was concerned Jim was her dad and that was it. I still feel that it would be good for her to meet Howard (her father), even though she says that she doesn't want to particularly. She says it would be really weird, like meeting a stranger, but I do think there's something there. (Mary)

For those mothers who made sure that their children had an ongoing relationship with their father, the need to make arrangements meant that they had contact with their ex-partners with continuing discussions pertaining to their children. This meant that the original family triad continued to exist in a geographically dispersed form. These mothers entered any new relationship with an active and pre-existing connection to her past situation.

Stepfamily Life

These final themes look at how dynamics within participants' stepfamily households were strongly influenced by the biological relationships within them. Mothers described experiencing themselves as a sub-group with their children, within the larger stepfamily. They were 'insider' members of these groups, while stepparents and stepchildren were 'outsider' members of these groups (see Papernow, 1993). Fathers also grouped with their children, so that families had the potential of including two or more sub-groups, which were characterised by shared history, culture, rules and opinions. I focus here on the mothers' perspective.

Groups and Sub-Groups; Biology, Culture and History

Out of the eleven women I interviewed nine were in second or third relationships.

Eight of these had ex-partners who were also in new relationships. This meant that with their father's new partners, these children had both a stepmother and a stepfather. There might also be children and stepchildren in new partnerships. Biological grouping in these situations had the potential for great complexity.

Where women had children from more than one relationship, dynamics within the families had the potential of being very complicated. These situations involved children being members of more than one household. I give some examples of the issues caused by these different sub-groups.

Barbara who had two children and four stepchildren described herself and her children as having a shared culture.

You have a particular relationship with your children; everybody does don't they? And you learn in families how to deal with things don't you? You know that there are certain issues you deal with in your own circumstances and somebody from the outside might think it looks a bit balmy what you're doing but you learned to know how things work best for you as a family. So I always thought about it within our bigger family, there is like me and my two children; a family, a unit. (Barbara)

Several mothers (myself included) felt that they were the central point between their partners and their children.

When Paul came along I couldn't have a relationship with him, it had to be me and the kids having a relationship and our relationship was difficult. My relationship with him was painful for me as a mother; I was split between being a mother or a lover. There was conflict between us. He was critical of the kids and that really hurt. I would find myself turned against him and then also the kids could get me against him by complaining about him. It was something that we couldn't quite talk about because he wouldn't see things like I did and I wasn't just able to stand my ground and not be pulled around by needing to please, needing to be accepted and not have him leave. I had a relationship with

them and I had a relationship with him but it wasn't working and the split was in me it felt like (Claire) .

From my own experience, because me and my partner don't have kids between us but we've each got kids, I was completely torn between my relationship with my kids and my partner. And then when my daughter reached teenagerdom there was real clashes. I always ended up being the one in the wrong. They both ended up blaming me you know, because I was trying to skate between and of course you never satisfy either then. My daughter would say I didn't stick up for her enough. My partner would say I wasn't tough enough with my own children. (Barbara)

I got together with Steven and just under a year after we got together we brought this house.... We were getting used to being in a relationship with each other but he was also taking on my kids and Amber was really hard work. I think she found it hard that Steven supported me in trying to get her to behave. I think her take on it was that he was telling her what to do. He wasn't telling her what to do, he was supporting me in telling her what to do. It put our relationship under strain..... It made my relationship with Steven tricky because I felt in the middle. I felt pissed off and frustrated with my daughter and he found it difficult, which of course he would because he'd had no experience of children of any age. I felt exhausted by it and had times where I just wanted to run away and let everyone get on with it without me. (Robin).

In these comments, both Barbara, Robin and I describe the difficulty of belonging to more than one sub-group and the consequent opposing loyalties.

Biology, Balance, Equality and Fairness

A further sub-group theme came about in those families where both partners brought children from previous relationships which seemed to be a need for balance. In these cases arguments between adults were often around each other's preferential treatment of their own children. This might be seen as a biological bias towards

one's own blood. Clody described compensating for unfair or harsh treatment of her children by their stepfather - her partner.

He put his children Susan and Ian in a bedroom each and Rob and Tom (my children) were sharing. It went from bad to worse; he couldn't seem to be nice to both the boys at the same time. If he was being nice to one of them he was being horrible to the other, or he was horrible to both of them. It turned me against his children in some horrible perverse way. I was worse than him because I was covert about it. (Clody)

Barbara described her partner viewing her parenting critically and vice versa.

I thought he was too soft with his own kids and he thought the same with mine. Sometimes when your kids are behaving badly you really don't want other people to witness it. But he never saw his own children behaving badly, particularly his eldest daughter. She went through a phase where she was absolutely awful, but you know according to him she was never quite as bad as what my children were. Because he never witnessed it. He was never at the end of it. (Barbara)

Barbara and Clody both seemed to feel that their partners were unjust. Clody described her partner's treatment of her children as unfair and her treatment of his children was connected with that. Barbara felt that her partner's perception of how she was as a mother was unfair. In both cases there was conflict between the parent and stepparent because of these differences.

In Leanne's family the situation of both adults having two children and none between them enabled her to feel less bound by her sense of parental responsibility.

Sometimes it got to screaming pitch and on those occasions, because Phil was there and some of them were his children, then I had an out. Because I could just say 'right I'm off to the pub' and jump in the car and drive off with my fags and a couple of quid in

my pocket. If all the kids had been mine I would've felt 'Oh they're my responsibility I've got to see it through (Leanne).

Thus it seems that for Leanne the balanced structure of her stepfamily situation allowed her to feel justified in a course of action she might not have had in a nuclear family.

I started writing this section with the intention of showing that divisions and conflict in participant's families were due to biological bias and a tendency to favour one's own. However this was not necessarily the only reason for difficulties in relationships. I placed an excerpt from Sally's interview here and attributed difficulties in the relationship between her son and his stepfather to the fact that her partner was not her son's father. In her interview she said:

Robert (my partner) had quite a battle issue with Ben (my son by my first marriage) and that caused tension between us. I wouldn't tell Ben off myself because Robert would tell him off. There was this feeling that I couldn't get the balance right because Robert would be quite strict with him and I seemed to be forever trying to explain to Robert that you didn't need to be strict with a three year old or a four year old. They couldn't necessarily live up to the standards that Robert was expecting. (Sally)

When I returned the findings to her and she saw I had quoted her in this section which I had originally named 'biological bias' she wrote to me as follows:

I'm not sure whether the problems between Robert and Ben were really because of a bias towards biological children: it's an interesting question. Prior to that, when Ben was just two, they had a very good relationship. I think the breakdown in their relationship happened when Robert went abroad. I think Robert's general inexperience with children was also very significant, and I can imagine a father being the same with their biological child. In the later difficulties that occurred between Robert and Ben, Ben having a father around was a big factor. This is a different but related point.

My own bias towards protecting Robin almost certainly had a lot to do with the fact he was my biological child and not my stepchild. And of course Robert may have had more patience with Ben when we were abroad, if he really had grown up with him from infancy onwards. But there do seem to be a number of factors involved here. (Sally, 2009)

Thus Sally felt that as a mother she was drawn to protect Ben, but that there were factors other than biology that were at the root of Robert's difficulties with him.

All the mothers in this section talked in different ways about balance and fairness. It seems that there was a difference between how they felt towards their children and how their partners did. Several felt that their partners judged their children and treated them unfairly. When this was the case it resulted in compensating behaviour on the part of the mother, as described by Clody and Sally.

Summary

When I was interviewed myself I realised that throughout my mothering life I have been managing my needs as a mother caring for my children – biology, 'natural motivation' - , my expectations of myself as a mother – duty, what and how I ought to be - and my needs as a woman in my own right – what I wanted and needed for myself, irrespective of mothering and my expectations of myself as a woman in my own right – what I ought to be. I found that these themes pervaded the narratives of the other women I interviewed and could be seen as internal motivations for some of their actions and feelings.

For example, there appeared to be a 'natural' mothering condition – a 'maternal pre-occupation' - that was described by many of the mothers as 'the start of mothering' (see discussion of themes on page 193 and Winnicott 1960, p3). This may be seen to develop into the commitment that many participants showed to looking after their children. However, participants also described what they expected of themselves as mothers and most had some form of self-criticism. I noted that several participants instigated the ending of their original partnership with the father of their children.

These women might have been seen as acting for their children's benefit, for themselves as mothers, or themselves as women. Thus within their stories was the sub-theme of the interplay between these different aspects of the women, as they manifested in the stepfamily situation.

Whether motivated by natural mothering instincts, or expectations of themselves as mothers, it can be seen that participants were proactive members of their stepfamilies, in many cases taking the lead on issues affecting their own children and providing physically for their stepchildren.

The variety of structures that were found among the participant group reflected differences in how each woman managed her family. Some participants' families looked like nuclear families excepting that one of the adults was a stepparent. These were families where the participant re-married (or partnered) and stayed with her new partner. Other women were involved in a series of relationships which frequently included new sets of stepchildren. In these families the mothers provided a consistent core for their children, while family memberships changed. This latter type of family tended to heighten the dependency and intensity that characterised the mother child relationship.

The biological facts of becoming a mother and the early relationship with their children seemed significant in how many mothers understood what it meant to be a mother. This was suggested by the fact that nine of the women spontaneously described this period of their mothering lives. For many participants early motherhood signified a change from being independent and autonomous to having a commitment to the care of their children. For them early infancy and childhood was a time of intense physical and emotional involvement with their babies and young children.

This was a time when all the women but one were in a relationship with their children's father. The implication seems to be that their original intention was to form a nuclear family with the father. The mothers reported several reasons for ending the situation, mostly because of a situation that had become intolerable in some way. There were three instances where the father was alcoholic and/or violent.

Other less extreme behaviour on the part of the father was equally difficult for the mother to tolerate and the relationship had become empty or antagonistic as a result²⁵. In the majority of cases it was the mothers who acted to change the situation by ending the partnership. (In two cases the fathers ended the relationship suddenly, each time leaving the mother with very young children).

The degree of shared parenting that took place between separated mothers and fathers depended on the willingness of the fathers to remain involved and the willingness of the mothers to involve them. The ability to make satisfactory arrangements between them depended on the amicability of the parents towards each other.

Smith describes resident mothers in stepfamily situations as performing ‘an additional layer of parenting’ which includes the mother functioning as ‘broker, mediator, and facilitator’ (Smith, 2008, p171). Because of these ‘gate-keeping’ tasks which relate to the non-resident father mothers in stepfamilies have been described as ‘the pivotal figure in the stepfamily(Smith, 2008, p162)’ and ‘the glue that holds stepfamilies together (Ganong and Coleman, 2004; quoted in Smith, 2008, p162)’. This seemed born out in this study where, from the time of when their relationship ended onwards, all mothers but one remained as primary carers for their children until their children left home.

As described by Smith, the mothers in this group ensured that the relationship between children and their fathers continued and were central in making arrangements between them. An interpretation of this behaviour might be that mothers felt that this was a significant relationship and continued to seek shared parenting to some extent. Another interpretation might be that mothers were determined to ensure that fathers shared parenting work.

²⁵ The sample of participants matched statistics coming from The U.K. New Stepfamilies Study, which showed that 34% mothers experienced violence in their first relationships (Smith, M., 2008)

It was striking that in common, all participants felt that living as a single mother was preferable to being in a difficult relationship. As single parents they were free to live with their children as they wished without having to deal with dysfunctional partners, extreme situations or unhappy relating. Furthermore single parenting frequently gave mothers opportunities to pursue interests outside of mothering, especially when parenting was shared with fathers on a regular basis. It also enabled them to have time on their own to pursue new relationships. Several writers comment on this period of single parenthood. Robinson and Smith describe it as one where children and their resident parent 'develop an emotional closeness that is different from that which preceded it in the two parent household' (1993, p181). Papernow describes a loosening of discipline and limit setting in single parent households (1993, p44).

Not all the participants were stepmothers as their new partners did not have children from a previous relationship. As stepmothers most women saw themselves as having a slightly different role than that of mother, in that most did not expect themselves as stepparents, to have primary responsibility. An example provided by one participant was that she had not made a commitment to be physically present for their stepchildren. It was not her job to *ensure* that her stepchildren were cared for. These differences suggested that stepchildren were perceived to *belong* to parents while stepmothers had more of a caretaking role.

Those women who were stepmothers all felt positive about their stepchildren now. However there were significant differences between how participants talked about their relationships with stepchildren than they did with their own. The clearest way to describe this is in terms of distance and connectedness; they felt closer and more connected with their own children. This meant that there was relative freedom in the relationship with stepchildren which potentially enabled that relationship to develop in a less complicated and enmeshed manner than between mother and child. Participants for the most part described being warm, concerned and friendly towards their stepchildren although there were exceptions. Clody for example described her jealousy towards her stepdaughter, founded on her stepdaughter being her father's favourite.

Another difference between relationships with stepchildren as compared to those with children was that they were less enduring. In two instances the ending of a relationship between adults meant the loss of school age stepchildren – although a connection remained in that those ex-stepchildren remained of interest to the participant. However another instance where stepchildren were adults when their father and the participant separated, the relationship between stepmother and stepchild remained strong. It seemed therefore that the length of time that the stepmother/stepchild relationship had existed was a factor in this.

Allen et al (2008) state that in stepfamilies ‘kin relationship’ demarcate different ‘kinship networks within which ...stepfamily members are involved’ whereas ‘in biological families...kinship networks tend to be integrative’ (p343). This is relevant to the dynamics that arose within participants’ families where friction was described as occurring between different biological groupings; i.e. mothers and children, fathers and their children or between mothers and stepfathers regarding their children and stepchildren. In these difficulties a common theme was mother’s wish for their children to be treated and perceived equally to their partners’ children and for all children in their families to be treated equally and fairly by their partners.

Where there was felt to be lack of inequality or unfairness in how their children were being treated by their stepfathers, mothers compensated in various ways. This might be through treating their stepchildren in an equivalent manner to how they felt their own children were being treated, to being protective of their own children, standing up for them in argument with their partners, or treating them more leniently. Thus how stepfathers related to the mothers children were important factors in the family dynamics.

Overall, the mothers showed themselves to be highly active, influential and core members of their stepfamilies, while the biological relationships that they were part of seemed to constitute a core network of relationships round which the stepfamilies were structured.

CHAPTER 6 – PRODUCTS AND DEVELOPMENTS

This chapter is concerned with activities and products that relate to the second objective for this doctorate i.e. ‘To work with others in generating knowledge about stepfamily issues’. There are three main areas where I have been working on developing and disseminating knowledge about stepfamily issues. These are: a) a series of experiential and educational workshops and conference presentations, b) the founding of the organisation StepIn ASAP and c) a book proposal. Additionally I have been developing working with groups using stepfamilies as a metaphor and have created ‘Biograms’ a new way of illustrating stepfamily structures based on biological connections.



Figure 10 - Products developed as a result of the doctorate

My own development might also be described as a product of this doctorate. I am able to work more confidently with clients on issues around mothering and stepfamilies in general. I am able to practice my psychotherapy from a deeper sense of what people are dealing with in their stepfamily situations. A steady trickle of people have begun to contact me about stepfamily issues. I have increased my understanding of what is going on in stepfamily situations, improved my writing skills and overcome blocks to learning and my overall lack of confidence.

Conference Presentations – Workshops and Groups

Since I started working on this project I have been offering workshop presentations at Gestalt therapy conferences. Over six years I ran workshops at conferences in Amsterdam, Athens, Bristol, London, Manchester and Vancouver. I additionally ran a workshop for the counsellors of the Raphael Counselling Center and with a colleague ran a day on Stepfamily dynamics for the Association of Humanistic Psychotherapy Practitioners. Appendix IV provides details of these.

These workshops presented the complexities of stepfamily dynamics. They did this in a manner that involved people creating their own learning rather than learning through lectures or teaching demonstrations. Each presentation was predominantly experiential, by which I mean that the aim was to put the participant into a situation that re-created what it *feels* like to be involved in a stepfamily dynamic. Thus I developed exercises that evoked stepfamily experiences that re-created aspects of stepfamily dynamics and representational activities that involved participants in role play (example follows, also see Appendix IV Workshops and Groups on page 453) The workshop content drew from what participants brought, so that each one was unpredictable and unique.

The first few workshops I ran all followed the same basic format. Typically, people would sit round in a circle; I would introduce myself and then ask people to introduce themselves and their connection to or interest in stepfamilies. Following this, I would give a short introduction to stepfamily issues and ask people if there

was a situation they would like to explore further. Someone would come forward and I would then set up a dramatic role-play that represented the situation with participants taking the parts of the different stepfamily characters, i.e. a stepmother, a child, mother, father etc. This would be under the guidance of the person who had brought the story. There would then be a re-enactment, with different areas explored. The effect for participants was strikingly powerful and evocative as the dynamics of the situations being represented would come to life in the experiences of the people acting the parts. It always seemed to provide some new insight for the person who presented, whether the role-play concerned their own family or that of a client.

The following is an example from a workshop presented for Gestalt Association UK. A therapist presented his client who had a new partner and a son. In a re-enactment, the therapist took the part of father while others represented the other characters in his client's family. The therapist very quickly understood that in the place of his client he felt impossibly caught between these people who all seemed to want something different from him. He felt in that position very emotional; impotent, angry, guilty and in grief. As someone who had not been in a stepfamily himself he found this evocation enlightening. He was able to empathise with his client and understand something more about the difficulties more generally faced in stepfamily situations. Later he contacted me to thank me as this had been helpful in working with his client.

As I continued running workshops I began to experiment with new exercises that demonstrated the impact of losing an original family group and the tendency to form biological sub-groups. The following are two examples:

Workshop i

Activity ***Workshop members were invited to talk together in small groups about what they knew about stepfamilies, and they stayed together in those groups for about twenty minutes talking together about their stepfamily experiences.***

Comment

This served several purposes: it put people in touch with what they knew about stepfamilies, it enabled them to learn from each other, and it established their group as a familiar base with people who had a shared history, albeit for a short time.

Activity ***The groups were asked to separate; two members left and two others from another group joined them. The instruction was for people to remain aware of their responses as this happened, how they felt with the new people, in their group, how they felt towards the other person from their original group and what it felt like leaving the original group.***

Comment

This deceptively simple exercise had powerful results, people became upset, remembered their own families, were reminded of being a child or became angry and reluctant to move out of the first group.

Whenever I introduced this exercise it provided rich material for discussion including issues around separation, attachment, stepfamilies and personal material.

Workshop ii

In this workshop I set no agenda other than to say that the purpose of the workshop was to explore how stepfamily dynamics and group dynamics might inform each other. At this workshop a discussion and interchange developed, with every incident being referred back to a stepfamily situation. Group members became deeply involved in this and discussion eventually led to one member revealing his regret about having left his first wife. It was apparent in this workshop that group dynamics and stepfamily dynamics did provide useful insights for each

other. The inspiration for this workshop arose from discussions that were taking place between the members of StepIn ASAP, which is described further in the next section. (Details of other exercises can be seen in the workshop outlines in Appendix IV)

The workshops were in every instance well received. They did not attract large numbers of people but those who came seemed genuinely interested in knowing more. Usually their interest came from a personal perspective or because they had a client who was presenting stepfamily issues. In almost every workshop I ran someone who had not previously thought of themselves as being in a stepfamily situation recognised that their family was a stepfamily.

I seem to be the only person running group workshops on this subject in the UK Gestalt therapy community. However putting on workshops at conferences depends on whether or not I am attending that conference. The ones that I do run generate interest, but being alone in running, designing and implementing them is limited. I have therefore needed some way to spread out and involve others. This has led me to found the organisation that is the subject of the next section.

Advancing Stepfamily Awareness through Psychotherapy

I founded the organisation StepIn ASAP, Advancing Stepfamily Awareness through Psychotherapy, partly to fill a gap in resources and partly to provide a forum where I could join with others to promote stepfamily issues, explore stepfamily issues, offer accessible and focused psychotherapeutic and counselling services, and develop informational resources. Details of StepIn ASAP and documents relating to new developments are included in Appendix IV.

With the demise of the National Stepfamily Organisation there has been no organisation in England²⁶ with a psychotherapeutic focus that is concerned specifically with stepfamilies. (Parentline Plus provides information and literature

²⁶ There is a Scottish Stepfamily Association which publishes literature and has a stepfamily helpline.

on stepfamilies and has a parenting advice helpline, but includes all parenting issues). StepIn ASAP as I envisaged it would have a therapeutic focus with advice-giving taking a limited role, It would need to start small as there was no funding to launch it other than my own and other interested people's personal finances.

I approached two psychotherapy colleagues who had been in discussion with me around stepfamily situations for many years: Debbie Friedman and Angelika Wienrich. My suggestion that we should found an organisation to develop knowledge on stepfamilies and work in that area was enthusiastically taken up by both of them.



Figure 11 - StepIn ASAP Activities

Together we contacted other therapists from a variety of orientations to join us and we became a core group of members; two gestalt therapists, a child therapist, two psychosynthesis oriented therapists, and a general practitioner who is also a psychiatrist and psychotherapist. This core group has been meeting every six weeks for over two years.

StepIn ASAP operates as a cooperative inquiry group. The four phases of inquiry outlined by John Heron and Peter Reason (2001, p180) are exemplified in how the group runs. Phase 1 is the initial formation of the group to inquire into stepfamily

situations. In Phase 2 we involve ourselves as subjects of the inquiry through exploring our own and each other's experiences of stepfamily situations in our lives and work. In Phase 3, courses of action, theory and ideas developed from the group are taken into the wider world. This might be working with a client, or offering a particular workshop. Phase 4 is the processing and discussion of the work. None of this is quite as neatly in order as the phases would suggest. Our meetings are informal and likely to be a combination of Phases 2 and 4, with action taking place in between meetings. In this way our work is also our research.

The group is now owned by all of us. The agenda for our organisation is formed by the whole group. We have a website (www.stepinasap.co.uk) and an increasing trickle of work and enquiries come through from that. We are building up a database of therapists throughout the country who will work with stepfamily situations and are becoming formalised so that we can apply for funding. We hope to put on a conference in the next year and to invite expert people in the field to be presenters.

We have been preparing to run a series of workshops. We set up and advertised a program of these (see Appendix IV page 466) two of which ran, but we found that we had to cancel the rest as we faced a difficulty. Basically while many people have expressed interest we rarely seem to have enough people together at one time to be able to run an event. We don't know why this is. Some of the feedback that has come to us hints that people feel unwilling to talk about their parenting in front of others. We wonder if they feel embarrassed or ashamed, convinced that they are bad people, or frightened of exposing themselves to their partners and people they know well. Therapists have said that they thought this a heavy and painful subject and have therefore avoided it.

We don't know whether these *really* are the problems and have therefore decided to research this. We have designed a questionnaire (on page 468) to be widely distributed that will help us find out from others what prevents them coming to workshops and what resources they would like to see developed. It may be that workshops are never going to be attended by many stepfamily members.

StepIn ASAP Member's Accounts

StepIn ASAP is unique in being a forum where we as professionals learn about stepfamilies through investigating our own and our clients stepfamily issues. We use experiential exercises to bring stepfamilies dynamics to life in the room and this has proved valuable to our client work and our personal lives. We feel as a group that our understanding is deepening. We see StepIn ASAP as having the potential to become firmly established, to become more diverse in what it has to offer stepfamily members, counsellors, and therapists and to be a prominent centre for psychotherapy, counselling, events, training on stepfamilies and information provision. We are slowly becoming known in the field, with people being referred to us and increasing requests for information from other therapists and the general public.

The following are accounts from StepIn ASAP members describing their involvement and how this has affected their work. The first is from Debbie Friedman – who has been involved in this project from its inception. She came to my pilot cooperative inquiry group (see extract of transcript on page 407), interviewed me for this project and is a founder member of StepIn ASAP. Other member's accounts follow.

Debbie Friedman MA

Psychosynthesis Psychotherapist, Trainer & Supervisor

Claire and I co-led a pilot cooperative inquiry group in 2005 which consisted of seven people including Claire and myself, a couple in a newish relationship with stepchildren on his side, two women in new relationships with stepchildren, and two female therapists with interests in the subject.

We were unclear at that point what a 'research' group might mean, and it seemed that Claire needed to take more of a lead than she originally anticipated, being more conversant, knowledgeable and steeped in the subject than the other participants, including myself. It was obvious to us that there was a need in the group for an

outlet at least for the expression of the difficulties encountered in the various stepfamily situations, and probably for some type of therapeutic context to be offered. The group seemed to consist of two sub-groups of professionals and clients even though this division was not the intention.

Following this Claire, myself and Angelika Wienrich (all psychotherapists) became founding members of StepIn ASAP, again with Claire in the foreground spearheading the project. We have been meeting every six weeks or so with colleagues who include a psychiatrist, a family therapist, a psychotherapist working with children, adolescents and families and another adult psychotherapist. (In line with the stepfamily model that we are developing there will be new participants joining the group in the near future). The training disciplines of the current members are varied, although we all seem to share humanistic therapeutic values and we all have personal experience of stepfamily situations.

Through our meetings we have been able to explore the subject both personally and professionally.

I was struck by the hidden nature of the 'step' situations and the degree to which so many people are impacted. For example, it was easy to assume that there were no stepfamily issues in my own (then current) family set up, only to realise the degree to which my partners throughout my adult life had all been affected i.e. they had had stepparents very early on in life. I had barely registered that my son had consequently been subjected to some extraordinarily complex stepfamily situations (as had I) and yet it intrigued me the degree to which I had scarcely taken this into consideration. I began to notice a similar theme in my own work with individual clients, which alerted me again to the way in which these stepfamily situations seemed to remain barely conscious, whilst exerting a significant influence.

We have often used our six weekly meetings for the supervision of clients and/or to report back or supervise the workshops that StepIn ASAP offers to member of the public and professionals working in the field. We have used role play, family constellation

type styles of working and also gained from each others' varying personal and professional experience. Claire has continued to take a central role steering the group and sharing her research, which informs our conversations and the shared thinking through of ideas.

One area that has particularly interested me is the development of a group model based on stepfamily dynamics which Claire has started to put into practice in the groups she leads. We have started to think about this collectively, and I can see for example how the inclusion issues, ever present in the training groups I work with, resonate more naturally with a stepfamily model.

To return again to the theme of what is conscious and what remains more hidden: we all recognise that the family has changed beyond recognition generationally, say from the pre war years, then baby boomer generation to the current family set up, yet the impact of this change seems not to have been considered fully enough. Even today, talking to peers, colleagues or family members, people shy away from the 'step' idea as it conjures up Cinderella-esque ideas of the 'wicked' step mother, in particular. Perhaps it is in part this uncomfortable image and identification that keeps driving the issues underground, which is one very key reason why it is so important to attempt to stay aware of these dynamics. Above all, when we have been able to explore in depth in the group, it is so clear that there is a tremendous opportunity for growth, creativity, compassion and a deeper shared understanding which benefits all of us. So I think we are developing a seriously useful therapeutic model, which could potentially break through the very entrenched psychological impasse regarding stepfamily issues (Friedman, 2008).

Jon Blend MA Dip Psych (UKCP) MBACP CQSW

Gestalt therapist working with children and adolescents in the National Health Service and in private practice.

I was attracted to joining StepIn ASAP initially to learn and reflect on my own experience of stepparenting as a fairly 'new on the

scene 'stepparent to a feisty teenage stepdaughter. Joining this experienced and multi-skilled group of professionals enabled me to explore and comprehend better some of the power games, rivalries, disappointments and losses that sometimes beset the path of my interpersonal relationships with members of my stepfamily network.

Through sharing our knowledge and experiences as parents, stepparents and colleagues, StepIn ASAP has become a safe place to experiment with new ways of being and thinking, somewhere to reflect on personal and family process. It is an invaluable resource. Developing greater awareness for example of my own capacity to demonise and denigrate an 'other' has enabled me to make more choiceful, less reactive responses when feeling frustrated for example with the biological parents concerned in my situation.

An important insight for me has come from understanding more about what Patricia Papernow calls the 'insider/outsider' tracks that come into play (Papernow, 1993); potentially affecting how I as a stepparent might relate quite differently to others in our network, where the presence and absence of our respective biological connections overlay and nuance how we as sub-groupings and families interact and gel.

As a psychotherapist and social worker working with children, adolescents and families within the NHS and private sector I regularly come across stepfamilies. I can apply some of my own learning from 'StepIn ASAP' to good purpose, helping clients own their projections and acknowledge some of the losses they have encountered en route to becoming part of a step family situation. This helps in reducing some of the reactive, impulsive, sometimes stereotypical responding commonly engaged in by warring families in an attempt to deflect from painful losses and shame. Encouraging hurting family members to find more productive ways of communicating than simply fighting, though often

experienced as relentless slog initially appears to bring long term rewards for those who stay the course, achieving more honest and respectful networks of care.

In response to my giving out the StepIn ASAP questionnaire at the family clinic where I work, our Consultant Family Therapist has suggested hosting an evening seminar about stepfamilies later this year, at which StepIn ASAP members will be invited to present. The aim will be to raise awareness of and broaden debate within our local Mental Health Trust concerning stepfamily issues and consider some ways in which professionals can assist 'stuck' or troubled families to move on towards achieving happier and healthier relationships (Blend, 2009).

Joan Bruggen

Systemic psychotherapist employed in a mental health and social care NHS foundation trust.

Before attending the ASAP group, as a systemic therapist, I was aware of the importance of step-parenting issues in working with families and with groups but I now feel much more tuned in to the nuances of emotions because I am listening in a different way. I feel that I am more able to ask the sort of questions which allow for discussion of being in a step-family from the different perspective of each member of the family. (Bruggen 2009)

Sue Fox Dip. Psych.

Psychosynthesis Training therapist and supervisor

I have been practising as a psychotherapist for nearly 20 years, and have experience with both individual and group work. I have always had an interest in family dynamics, which originally stemmed from working within the field of addiction. My interest in stepfamilies seemed a natural step given my background, but also grew from finding myself within one, and also knowing and speaking to both friends and colleagues about the challenges that this brought.

I was invited to join StepIn ASAP to bring both my experience, gain support and to participate in developing ideas to help those who were finding themselves struggling and floundering within a complex set of dynamics.

What became clear within my work with individuals was that bringing this context to the work gave the client a perspective and understanding that then allowed them to approach and relate in a way that helped to transform the negative into a positive experience (Fox, 2009).

Angelika Wienrich

Gestalt psychotherapist, group leader, supervisor and trainer at the London Gestalt Centre. Also works in private practice and runs writing workshops.

I was enthusiastic and keen to be involved in forming StepIn ASAP in order to raise awareness related to issues and the therapeutic needs of people in stepfamilies.

My first contact with Claire was in a workshop on stepfamily issues during a conference - I attended this to support her, thinking that this really had little to do with me. It didn't take long for it to dawn on me that it was indeed relevant to me as my children had had a stepmother (albeit a part-time one) for nearly twenty years until she died of cancer. Even though my children only actually lived with her and their father for one year she was a regular part of their life and had a lasting influence, especially on my daughter.

I think my example is perhaps not uncommon and may explain the difficulties we have had in attracting ordinary people to come to our workshops - I certainly would not have felt it related to me before I realised! On the other hand those who are consciously and deeply involved with stepchildren or stepparents may feel like many do when in a crisis; i.e. you simply have to get on with the job. Parents and stepparents may also have issues around

shame and guilt, and no real sense of how they can be helped. My lack of awareness that I was in a stepfamily situation has raised my awareness in relation to a sense that there is a similar haziness when stepfamily issues come up with clients. As there are perhaps one in three or four clients for whom this is the case it has begun to raise curious questions, to which there are no simple answers, but which we as a group have an ongoing dialogue about.

While it was hard to get people to come to our workshops it has not been difficult to get together a group of six local psychotherapists to be involved in exploring stepfamilies. I have found it supportive both personally and professionally to meet regularly. The most benefit of my involvement so far is in working with stepparents rather than especially for those who have been stepchildren. I see this as providing a kind of preventative therapeutic effect,

For me personally it has helped considerably to have a dialogue with my own children about their feelings for their stepmother - and, as I am now in a relationship with a man who has two grown up sons, it has sensitized me I believe to some of the feelings they may have about me and my relationship with their father (Wienrich, 2009).

Dr. David Zigmund

General Practitioner, part-time NHS psychiatrist and psychotherapist in private practice.

Although I do not now do any 'formal' family therapy, this perspective remains an essential part of my thinking and practice. Compound families and stepparenting are now ineluctable parts of our culture. Our understanding of their complexity must be developed if we are to helpfully engage with large numbers of

people struggling to improve their understanding and modae vivendae.

Claire and her StepIn group play host and facilitator to these endeavors. I am grateful for these. So too, indirectly and unconsciously, are many of my clients and patients (Zigmund, 2009).

Using the Metaphor of a Stepfamily to Understand Group Process

In our discussions at StepIn ASAP we are developing a model of group dynamics using stepfamily situations as a metaphor. This is an area that we are beginning to think about; a concept the potential of which we do not yet know. Examples where this applies within therapy groups are issues that arise such as dual relationships, absent members, subgroups and boundaries, all of which are situations that stepfamily members often have to deal with. This is discussed more fully in the following chapter (on page 199).

Working in this way is the beginning of thinking about how group work seems to benefit from a stepfamily model which allows for complicated, unequal and dual relationships, biased alliances and including/excluding feelings. While this might sound messy, members of such a group would potentially develop resilience, tolerance of difference, and understanding about connections and attachments, both in the group and in their own lives. They would perhaps learn to recognise and accept uncomfortable feelings that arise in these circumstances. A stepfamily metaphor makes sense of the disruption group members feel when there is change or the fear of disintegration when members leave.

I have used the metaphor of a stepfamily as a guide to running a fortnightly therapy group that I co-lead with Angelika Wienrich. It is an ongoing group and new members can join at any time with an initial commitment of six groups. There are eight current group members, six of whom are Angelika's individual clients, one is my individual client and one used to be my individual client. Thus all the members have an individual therapeutic relationship with one or other of us. This setup automatically creates two sub-groups within the group, with myself and my ex-client in the minority; it may have been impossible to work with this group had we not used the metaphor of a stepfamily to help us understand some of the dynamics. We saw ourselves as a stepfamily, Angelika and I were like two parents, each bringing children from a previous relationship and were both 'parents' of our own clients and 'stepparents' of the other's clients.

Angelika and I each already have a relationship with our own clients and have had to establish a relationship with the other group members at the same time as developing *our* relationship as co-leaders. Angelika and her clients are party to a relationship that I am not part of, as am I with my own clients. These relationships bring about two sub-groups within the group-as-a-whole consisting of the larger group of Angelika and her clients, with the smaller group of myself, my ex-client and my current client. This grouping is in addition to other sub-groups that members might be seen to also belong to within the group, i.e. men and women, facilitators, peers and so forth. We are all members of our respective sub-groups at the same time as all being members of the same group. This is a similar situation as a family that consists of two parents who are stepparents to each other's children.

Here is an example of how these dynamics manifested in group member's behaviour. A client of Angelika's ignored me for several group sessions and when questioned on this admitted seeing me as an unimportant addendum to Angelika; like an unacknowledged stepparent. Others of her clients have tended to focus on her and excluded me so that at times I have felt like an ineffectual outsider; very much in a stepparent position.

Another time two new members who were both clients of Angelika's were set to join the group. I found myself feeling anxious about how this would affect the group as a whole. On reflection I realised that this was my own fear of having two more people come in who had worked with Angelika and not with me. Through considering the metaphor of a stepfamily I realised that feared that these new clients might each feel towards me as a child might feel towards an adult who was in the stepparent position. The new members might feel jealous of me, mistrust me or feel that I was taking Angelika away from them in some way. This consideration led me to arrange a meeting prior to the group with each of them and with me and Angelika, partly to be introduced to them and also to raise these issues if they seemed relevant at the time. This seemed successful in easing their entry into the group and beginning their relationship with me.

Using the model of a stepfamily to understand group process has helped me as a group leader to recognise undercurrents in the group that I might have otherwise missed. With this model as a focus I have been able to watch for divisive, including/excluding behaviours among group members, and to recognise parental transference. Occasionally in the process of understanding within the group, the stepfamily has been discussed there and this has been effective in shedding light on group feelings and behaviours.

These ideas about stepfamilies and group process are part of an ongoing exploration that has been taken up with enthusiasm within StepIn ASAP. Frequently we compare our own processes to stepfamily processes. A recent example comes from the need to set up a Management Committee. I sent around an email with initial suggestions about this (on page 470). The following response came from Sue Fox:

I am interested in my reaction to this which I want to share, as within it I am thinking about it in relation to stepfamilies. Initially I felt excited by your email, and then as I read through the document, felt myself feeling quite excluded, a bit like an extra...I then find that I want to withdraw, as " the biological family" is getting on with it without me. It is then difficult to muster up interest in being more involved when the roles have already been seemingly allocated (Fox 2009).

This is an example of how a stepfamily metaphor is useful to thinking about our organisational dynamics. Feelings about insider and outsider groups have now become part of our conversation as we work towards becoming a more formal organisation. The stepfamily metaphor gives us a frame within which to think about such dynamics.

Stepfamily Situations and Therapy Group Dynamics

The following section looks more closely into the theory behind what happens in therapy groups and the use of stepfamilies as a metaphor. Throughout this

discussion I use the terms ‘groups’ and ‘group leaders’ to mean ‘therapy groups’ and ‘therapy group leaders’ (see glossary). I use ‘workshop’ to mean a focused experiential educational group.

Therapy groups have the potential to be dynamic, creative and nourishing, and also can be frightening places where the group has the power to reject and alienate an individual. Bion describes well the uneasiness experienced by group members as they deal with issues of dependence, independence and inclusion (Bion, 1961). Because of these tensions members need to summon up courage and willingness to take risks.

Group dynamics is a huge area of study that has been of interest to writers from many therapeutic orientations, including psychoanalysis, Gestalt and family therapy, as well as psychologists such as Lewin (see Feder and Ronall, 1980; Smith, 2001). There is no possibility of beginning to do this fascinating and complex subject justice here, so I limit myself to a brief consideration of issues that are closest to those being dealt with by stepfamily members. The suggestion I am making is that through recognising the parallels between stepfamily situations and certain group processes, therapy group leaders can work more responsively with those processes.

Yalom described therapy groups as resembling a family in that they contain ‘authority/parental figures, peer siblings, deep personal revelations, strong emotions, and deep intimacy as well as hostile competitive feelings’ (Yalom, 1995). In keeping with this, group members are concerned with issues of cohesion, membership and leadership among others (Cartwright and Zander, 1953; Houston, 1993; Yalom, 1995; Feder, 2006). Thus members of therapy groups that have run on an ongoing basis for a period of time without people leaving might feel that they belong in the way that they would in a family.

Such a therapy group is likely to have a home – a regular meeting place. In fact it can take very little time for people to feel that they are part of a group, to have some level of attachment to that group and an investment in its survival. For example I found that in workshops I ran which aimed to produce a family-like sense of membership, people felt identified with others in a small group within ten minutes.

Once this cohesion has happened, the group tends to develop firmer boundaries and an identity that is threatened by change.

Time is a factor in group cohesion, so that groups which stay together for a long period without change of membership can become like nuclear families in that members share a history within the group, they develop a culture and identity, and share the same leaders who might be seen as parental figures. This can be seen in some training groups, which are sometimes ongoing for several years. Other groups that have to deal with frequent change, with new members joining, and older members leaving, seem closer to stepfamilies in character. New members are often perceived as 'other' or 'outside of' the older group members; their different expectations and culture being seen as a threat to the established one. If two groups join, (equivalent to two families joining to form a stepfamily) the groups are often suspicious of, and threatened by, each other.

This was illustrated in Gaie Houston's book on group behaviour 'Being and Belonging' (1993). In this fiction that illustrates theory, she describes a group of disparate characters (Group A), all therapists representing a variety of orientations, who meet for a week to train with a leader. For various reasons the leader doesn't get there. At the start group members argue and fight between themselves as they establish their place in the group and their relationship with each other.

However it becomes apparent that Group A has developed a sense of cohesion and identity when they encounter another group (B) meeting in the same building. Territory becomes important as the two groups have their own areas for meeting. Members of Group A dislike and are reluctant to meet with members of Group B. Their words towards them are disparaging; they don't like how Group B members dress or their taste in music. In this they see themselves as superior and position themselves as an 'in-group'. Behind this, Group A members fear of being overtaken by Group B, of losing their sense of identity, of becoming an 'out-group' and that they will lose the group that they are and become something different. They fantasise this as a battle where only one group will have supremacy. As one of the members from Group A says

We shall be invaders this morning [going into their territory] so the other group will have the terror that we are taking them over. But we are fewer than them, so we shall have the terror of being taken over. We think we are better than them.....we secretly fear they may be better than us'. In a meeting between the two groups issues of power and different forms of sub-grouping are explored and the divisions begin to break down (Houston, 1993, p176).

The dynamics described within this story are relevant to stepfamily situations where members of two or more family groups join together. In such circumstances strong emotions can be evoked. The threat of clashing cultures, the wish to cleave to what is known, loss of both identity and shared history are among the fears that new stepfamily members might face. This is perhaps enhanced by the sense of loyalty and connection felt between children and parents and that new members might be perceived as a threat to that relationship. Thus, while recognising group dynamics may be helpful in understanding stepfamilies, the opposite is also true; recognising stepfamily dynamics might help understand certain group processes.

The loss of an original group and the threat caused by change was illustrated in a workshop I ran for the Raphael Centre (see Appendix IV). I suggested that small groups of adults imagine themselves as a family consisting of a mother, father and two children. After a period of time I instructed these groups to split up and for a parent and his or her child to join another group. There was great reluctance to do this, people didn't want to, they argued about which two would leave. In their second groups a variety of reactions arose, 'children' felt left out, they didn't like each other, some became silent, others said that they felt regressed. This was reported to be a very emotional exploration.

Understanding what this means for members and group leaders is important. There are some examples. At the beginning of a group, members do not know whether they like each other or not. Possibly they have very different backgrounds and it takes time before they become familiar with each other. Thus ongoing group members are often disparate; they have had little to do with each other before joining a group together and except at the very start of a group are likely to have joined at

different times. Therefore, as is the case in a stepfamily, members have different histories within the group and different allegiances from each other.

Group facilitators starting a group with people they do not know have to establish a relationship with them, much as a stepparent has to establish a relationship with stepchildren. Authority of the leader cannot be assumed. This may especially be the case if a group leader takes over a group that has been run by someone else.

Training groups where members remain the same but change leaders for different terms or years are likely to experience disruption related to this. Other ongoing groups frequently have a changing membership with new members being seen as stepsiblings and/or outsiders.

People leaving disappear from a group's life – as might a family member who leaves a stepfamily, but as I have found in a group I run, their memory lingers on and events bring those memories back to the surface. In this case I founded an ongoing group with another therapist - my co-leader (the equivalent of another parent) left to return to Australia. Three years later a group member who had been her client expressed his regret that it was her who had gone and I who had remained. He had been afraid to tell me that before.

Conflicting allegiances might also be a feature of group dynamics, with members being unsure of where their loyalties lie, e.g. to partners outside the group, their peers, the group as a whole, or the facilitator. I have found it valuable to manage these situations by thinking of how the group might be like a stepfamily. In Chapter 6 on page 183 I have described my application of these ideas to an ongoing therapy group that I co-lead with Angelika Wienrich.

The idea of the therapy group as stepfamily has the potential to provide a useful metaphor for situations that can be problematic in groups. Examples are dual relationships between leaders and participants, (as in mine and Angelika's group), situations where two groups join together, and boundary issues where members belong to more than one group. These considerations are among those being explored further by members of StepIn ASAP.

Biograms

Biograms are a different type of product as they were a tool which I developed in order to analyse stepfamily structures. I have also been using them in my therapy work as a means of exploring client's family structure.

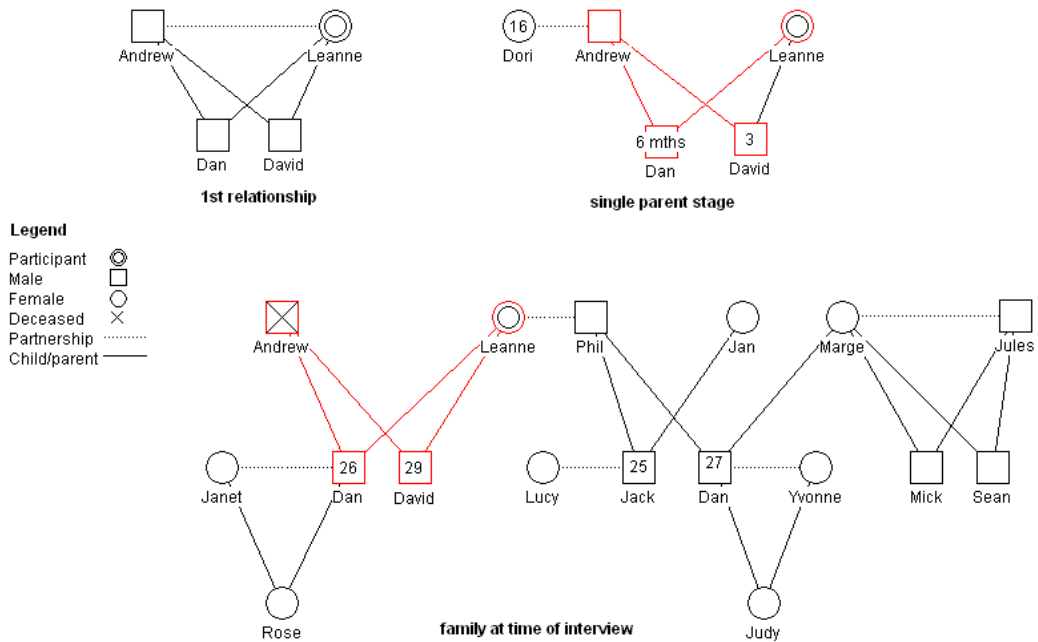

Figure 12 - Leanne's family Biogram

I devised 'Biograms' in order to explore the structure formed by biological relationships within stepfamily situations as part of my earlier project 'Couples in Stepfamilies' (Salisbury, 2004).

Biograms show blood relationships as direct links between children and parents so that these are emphasised, while marriage or partnership lines are de-emphasised. Thus they show solid lines between biological/blood relationships i.e. parents and children. Current adult relationships (marriage or co-habiting) are indicated by a dotted line. There is no distinction made between marriages or cohabiting relationships; current partnerships are represented and no direct lines drawn to represent past marriages or relationship. Past marriage/relationship lines are omitted. Therefore what remains shows ex-partners as connected through children.

In this way Biograms are fairly simple. Compared to Genograms which they were based on, Biograms are more organic and flexible.

Figure 12 shows a sequence of Biograms that represent Leanne's family, from the beginning when she was married to Andrew, through her time as a single parent to the situation she is in now, where she is cohabiting with Phil. Through following the lines connecting biological members, it can be seen that Phil has two sons with Jan and Marge and that Marge is now in a relationship with Jules and has two sons Mick and Sean. There is a third row which represents Leanne's grandchildren.

One of the features of the Biogram is that couples who have children together become represented by triangles, whereas couple who do no have children are joined through their children to their ex-partners, as can be seen in Leanne's first relationship. Triangles are strong stable structures without much flexibility - indicating resilience. When parents separate the effect in the Biogram is of stretching out the original structure and creating the space to allow the new member to join. Thus Biograms illustrate that when separated parents join with new partners, the structures of their families become more open, less sturdy structures and have increased flexibility.

I have created Biograms for the families of each of the mothers I interviewed. These vary in complexity and show the huge variation of family structures among the women who participated (see Appendix I p233).

Book Proposal

I have put together a book proposal aimed at an audience of therapists (see Appendix IV p473). It is aimed at counsellors and therapists. The idea is to include first person narratives, discussion and exercises and involve readers in thinking about the issues contained in them. Thus it can be used by individual therapists and as a teaching/training tool. If a publisher can't be found then I intend to self-publish.

Conclusion

In this section I have described the various forums in which I am promoting stepfamily awareness and products that are arising from the research itself. These include therapy groups, individual therapy, workshops, group theory, exploratory tools and the founding of the organisation StepIn asap. Each of these could also be seen as a research activity, in that they have contributed to what I know about stepfamilies.

CHAPTER 7 – REMAINING ISSUES

This chapter considers the issues that have not been covered in previous chapters. Discussion of the thematic findings discussion of thematic findings (see Chapter 5.) is followed by consideration of the contexts and limitations of the project and issues regarding validation. This includes a subsection on closer consideration of the client group. The final section concludes this document. It provides a summary of the whole project and its influence on the psychotherapy field, identification of areas for further research and the outcomes for my own psychotherapy practice and for me.

Discussion Arising from Themes

The research question that this exploration was founded on was ‘What can I find out about stepfamilies through the experiences of mothers?’ From my investigation I gained information about what a small group of women from similar backgrounds have to say about their experiences and these might be seen to indicate trends in the larger population. This section looks further into the themes that have been presented as the second part of Chapter 5.

The Importance of the Early Mother and Infant Relationship

More than half the participants spontaneously talked about the birth of their first child and the early period of mothering (see *Becoming and Being a Mother* on page 134 and summary on page 163). As noted earlier a woman becomes a mother on the arrival of her child, the culmination of her pregnancy and changes that take place in her body and mind during that time.

There is a psychoanalytic interest in the relationship between mother and baby as regards infant development. I have been drawn to Winnicott and Stern who write and research in the field of Object Relations as their writings speak to how I felt when my children were born.

On this period of mothering Winnicott said “the mother’s bond is very powerful at the beginning’ (1964, p26) and described maternal love as ‘a pretty crude affair. There’s possessiveness in it, appetite, even a ‘drat the kid’ element’ there’s generosity in it and power, as well as humility” (p.17). Some of this is echoed in these mothers’ words. Winnicott observed that as pregnancy progresses the mother has ‘an increasing identification’ with the infant (Winnicott, 1960, p3) which gives the mother her willingness and ability to ‘drain interest from her own self on to the baby’ (p15) a state that he termed ‘primary maternal preoccupation’.

From this perspective the statements made by the mothers I interviewed represent their subjective experience of a complex reorganisation of their world that takes place at the birth of their child. Thus it seemed that these women were describing an initiation a new construction of themselves in which they were no longer independent. This was suggested by several women describing this as the time when they accepted responsibility for the care of their children.

Stern also suggests that on the birth of her child the mother passes into ‘a new and unique psychic organisation’ and lists four themes that concern the new mother. In his model the mother is able to respond to her baby’s needs through identification. This is the *primary relatedness theme* which relates to her ability to love her baby and feel love from her baby (Stern, 1998, p176).

Winnicott noted that some mothers were unable to enter into this state and put this down to her self interests being ‘too compulsive to be abandoned’ (p15). Amanda was an example of a mother who was unable in the first instance to become preoccupied with her baby as Winnicott describes it.

I took one look at my baby Tom and started bawling my eyes out and going back to bed. I think I saw in him me, the abandoned baby, and I didn’t know what to do.

Stern also recognises a mothers identification with her baby as beginning during pregnancy. He suggests that prior to birth the baby is represented in the mother’s mind. At birth the represented baby and the real baby meet with greater or lesser

accuracy (Stern, 1998). He describes the mother as discovering ‘who she is turning out to be as a real mother’ (1998, p23) and of the baby ‘turning the woman into a mother’. The baby in this view is teacher and the mother as pupil is learning how to respond to her child, from her child.

A critique from this comes from feminist thinkers who attach identification to gender. They suggest that these are particularly strong between mother and her daughter from infancy by virtue of the mother also being a daughter and therefore seeing her child as a reflection of her own earlier self (Orbach, S. talking to Hollway, 1997; Lawler, 2000). This possibly is more relevant to a later stage of child development. As regards the mothers I spoke to no such distinction was made at the early stage of their children’s lives. However, issues of identity arose for Amanda, when her daughter was older.

The perspectives from Stern and Winnicott, are commensurate with the comments of mothers that suggest a special relationship with their child. At the birth of a child these mothers experienced new sets of identifying feelings. Undoubtedly they were aware of the growth of their child inside them during pregnancy. Therefore some form of ‘relating to’ must have been taking place before birth. The overall implication is that the biological circumstances of being a mother were a strong influence on how they related to their children.

The Importance of Fathers

I found that the interview material suggested that fathers also had special feelings towards their own children and that the participants supported their continuing this relationship.

Most of the women, including those who had difficult relationships with their ex-partners, seemed to accept this. Continuing contact in some form with a father was questioned only when he had been abusive to the mother, was considered dangerous for the children or had not been involved since a child’s birth as in the case of Mary (see below). Most of the fathers seemed to accept some responsibility for their children’s care, although their contribution towards this was usually less than the mother’s. The account of Bella’s daughter seeking out her alcoholic father in later

life and of Mary's daughter keeping a photograph of her father in her room suggested that children also attached importance to an ongoing connection with their father.

In the majority of instances it was the mothers who ensured that their children continued to have a relationship with their non-resident father. Several mothers facilitated some level of contact even when the father had appeared to be uninterested or as in one case, unreliable and often too drunk to be trusted to look after their children safely. My explanation for this was that most mothers valued biological relationships and felt that it was important for their children's wellbeing to have a connection with their father. However, this reasoning is not supported by evidence. Jan Pryor writes that there is 'surprisingly little support [through research] for the benefits of contact in itself for children's wellbeing [and that] *quality of involvement* appears to have the most measurable benefits for children (Pryor, 2008, p355, my italics).

There may be other explanations for this behaviour. Perhaps having the fathers remaining involved benefited the mothers in some other way. One thought was that mothers, through making it possible for fathers to spend time with their children, also made it possible for themselves to have time off from mothering [see Robin's account of single parenthood on page 156 and Lawler (2000) on activities outside of mothering]. Alternatively this may be an example of the mothers' viewing it as possible that after separation mothers continued to consider parenting as a shared task and therefore insisting that fathers do their part.

In support of the concept of biological relationships being special, Daly and Wilson (1998) describe parents as having an investment in genetic posterity (p24). They suggest that motives and emotions have evolved to promote fitness (in the Darwinian sense) and that in this respect a child's well-being has the same impact on both parents. Thus they suggest that the tendency for parents to be interested in their children beyond separation has biological causes. If this were accepted then it would make sense that a father continued to have an interest in his child even when he lived

elsewhere. A mother would support this; as she would recognise her ex-partner as being the only other adult with similar concerns for her child as herself.

However Lawler (2000) suggests that in Western, Eurocentric culture the way that parents perceive their children as part of themselves is a social construction. Thus parental interest in their children does not come from an inbuilt biological motivation but from a *socially constructed perception* of genetic continuity. Genes are perceived as an inheritance that is passed down through generations ‘from mothers and fathers to their children’ (p59) so that the child/baby is seen as containing bits of the parent (Lawler, 2000). Both of these arguments acknowledge that parents have a special relationship with their children but differ in the causes of this.

My hypothesis that stepparents did not have the same feelings towards their stepchildren as parents do towards their children led me to interview Mary (previously mentioned on page 157). Mary was unknowingly pregnant with her ex-partner’s daughter (Grace) when she met Jim. He is still her partner and they have two other children between them. I imagined that I would find that Jim treated Grace differently than his other two children as she was technically his stepchild; however this was not the case. Jim felt that he *was* Grace’s father and vice versa. As Mary said:

He was there at the birth and when she was born he immediately fell in love with her. It was like she was his from then on really.

However Mary was convinced that Grace also needed to know her biological father even though she already had a father in Jim. She saw this as necessary for Grace’s wellbeing and noted that Grace kept a photograph of her biological father in her room.

I found several points of interest in this story. Firstly that being present at Grace’s birth enabled Jim to accept Grace as *his daughter*; perhaps this was similar to how other women in this study had described taking on responsibility for their children at birth. I wondered whether emotions that arise in the birth process itself had

something to do with motherly and fatherly feelings towards children. Secondly Mary had a very keen sense of Grace's needs. This was an empathic quality that other mothers also demonstrated. Thirdly it was Mary who felt responsible for Grace's contact with her biological father and who wanted to facilitate that. I interpreted this as Mary *recognising* that Grace needed a connection with her father for her emotional wellbeing. It was however possible that it was Mary who wanted a connection with this old partner and *projected* this need on to her daughter.

The Importance of Biology to Stepfamily Dynamics

I found that biological connections formed the basis for sub-groups (see glossary) within participant's families. As I found in my earlier investigation on stepparent/parent couples (Salisbury, 2004) sub-groups were frequently a characteristic of participants' stepfamily dynamics with the potential for family members to have allegiances that extend beyond the boundaries of the household. Several situations were described where mothers formed an insider group with their children while new partners and their children were seen as outside of that group. These mothers described themselves as being pulled between allegiances to their new partners and their children (see Stepfamily Life, Groups and Subgroups on page 158).

According to other writers a feature of stepfamilies (Allan, Hawker et al., 2004) is that they have usually had a history of considerable upheaval and change of household membership. Winnicott writing on what contributes to children's emotional security states that 'parents who can manage to keep a home together provide something immensely importantwhen a home breaks up there are casualties among the children (Winnicott, 1965, p30). In a stepfamily, a home *has* been disrupted. A parent *will* have left and new members in the form of a stepparent and possibly stepsiblings may have joined the family group.

In contrast, nuclear families where, other than when new children are born and older ones leave, membership tends to remain consistent with all children being equally

related to the adults²⁷. Nuclear family members develop a shared culture and history that starts at birth for children and earlier for the parents). These factors contribute to a sense of cohesion by which I mean that each member feels part of a group that they belong to. Therefore there is a whole area of sub-grouping based on biology, history and culture that cannot happen in nuclear families but which does in stepfamilies. There were several examples of this given by participants.

Another contrast between nuclear families and stepfamilies is that nuclear families constitute a bounded group of biologically related members. It is usually clear who is included and not included in the family. However in stepfamilies, where parents and children live in different households, boundaries are harder to define. These characteristics showed up in the Biograms I made of participants' families which can be seen in Appendix I on page 248. Biological relationships within nuclear families formed triangles which as structures are sturdy, robust and enclosed. In contrast, stepfamilies biological connections created zig-zags; forms which were flexible and can be stretched or contracted. These seemed illustrative of the characteristics of these different family groupings.

The narratives from mothers therefore showed that compared to a nuclear family, their families had many potential difficulties. The participants however did not appear to be a depressed group. Most of the women seemed to be mature and to have gained understanding of themselves, toleration of difference and personal maturity through their family experiences.

Changes to Project Design

In the following section I describe how the process of investigation moved away from the original plans for this inquiry and my rationale for this.

²⁷ This is true except in cases of a child having been adopted; a related area to stepfamilies but with important differences. For example in most cases of parents have chosen to adopt a child, in stepfamilies children usually come along with an adult relationship.

Implementing the activities of this project I followed a creative path, based on the design set out in my Learning Agreement (henceforth LA) but with more flexibility than I had suggested at the time (see Appendix II). This has resulted in some variation from that original design, partly by my being unable to anticipate the direction doing the research would take me.

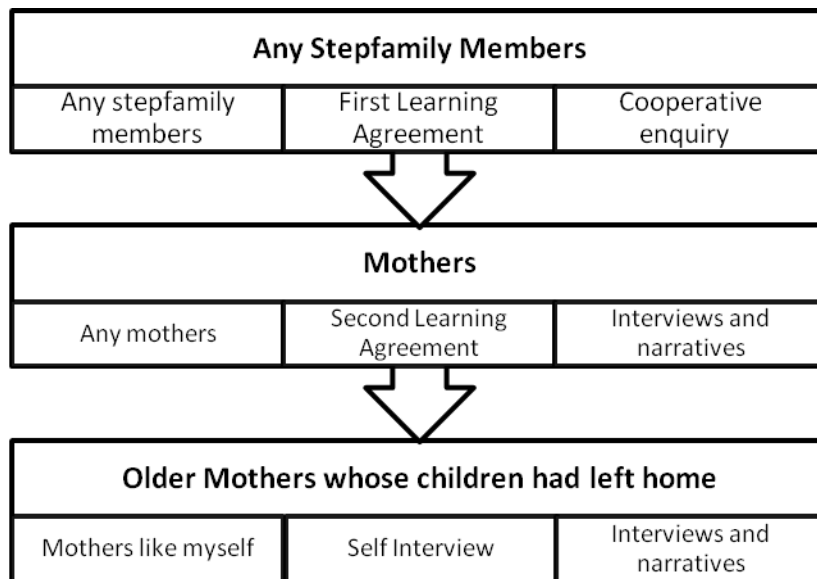

Figure 13 - Refining Criteria for Participants

The following quote from ‘Succeeding with your Doctorate’ (Wellington, Bathmaker et al., 2005) concerns this:

In many cases it is necessary to put together a research proposal before having started properly on the research.....this is difficult as a front-loaded exercise andit involves issues that you will continually need to contend with throughout the study’.

The original design for this project contained lists of research methods and anticipated products from this doctorate which are included in Appendix II both of which I changed. The most important of these changes relating to the research was the refinement of criteria for choosing participants. Figure 13 - Refining Criteria for Participants on page 200 shows the forums within which the focus was refined. I now give a brief history to this process as it shows how I adapted the design in response to information that I gained through its implementation.

I submitted two versions of my LA. In the first of these I proposed to explore stepfamily dynamics using Cooperative Inquiry and Action Research (Reason, 1988) with a group of stepfamily members and professionals (top level of the triangle in Figure 13). Eager to get going, I convened two pilot focus groups (see extract of transcript on page 407) before I submitted my LA. I was asked to rewrite, to consider my role as researcher in relation to the data and to revise my methodology. These two suggestions from the panel led me to decide to get data from a group that I belonged to i.e. mothers in stepfamilies, to include my own experience in an unspecified form as data, and to use a narrative methodology (Asherson Bartram, 2006). This design was accepted.

Being interviewed myself was the first improvisatory research procedure I introduced. As described earlier (on page 68), I did this as a way of obtaining my own data and placing myself in the interview as well as testing the efficacy of the phenomenological interviewing I had envisaged (see section starting on page 67). Included in the feedback from my second submission was the question ‘what will be your criteria to define participants?’ I was able to respond to this after I had been interviewed as I decided to focus the criteria for participation on mothers like myself so that I could be part of the research sample. To reflect my shift of focus I changed the title of the project from ‘Stepfamily Dynamics’ to ‘Narratives of Mothers in Stepfamily Situations’.

Another example of my improvisatory approach to the research can be seen in how I ‘discovered’ the procedure of creating first person monologues as described (see pages 76, 95 and Appendix I). This was a research activity I had not previously anticipated which arose from an exploration of the first interview transcript. Both of these examples are of developments that arose out of an interpretation of the original design set out in the LA.

Products have also developed differently from my original intentions as time constraints meant that I have done very little writing other than this document. I was hoping to have a publishing offer for a book by the time I had completed the project and have prepared a proposal (see Appendix IV); finding a publisher is work in

progress. However a product that was not part of my original vision of products has come into being with energy and momentum. This is the organisation StepIn ASAP, which I founded with two other practitioners and which I described fully in Chapter 6. This is now an active organisation, involving a core of seven therapists exploring stepfamily issues and developing our own products which include psychotherapy for people in stepfamily situations, a website, resource list and programme of workshops (see Appendix IV). This organisation is growing, and is in the process of being formalised, with a mission statement and a constitution, so that we can apply for funding.

Thus I interpreted my original design with creative flexibility and followed a research path that, like the yellow brick road (in *The Wizard of Oz*), appeared before me as I walked along it. There has allowed me to pursue unforeseen developments, and to improvise. In the next section I reflect on the contexts of the project followed by issues of validity.

Context, Limitations and Strengths of this Project

Throughout my time working on this project I have been living with the question ‘how does this research into mothers transfer to the wider group of stepfamily dynamics as a whole – if indeed it does? What does this project contribute to the field of psychotherapy?’

In order to shed light on these questions I look into various contexts within which the project has taken place, a more detailed consideration of the characteristics of the participant group, strengths and weaknesses within the methodology and issues that have arisen within the research.

I start with considering the group of participants as a whole.

Participants

The forums in which I looked for participants reflect the context within which this project took place. I work privately as a psychotherapist and do not have access to

participants through an organisation I am part of. I did not want to complicate my relationships with existing clients so I turned to work colleagues and friends.

Lawler, commenting on her own similar procedure for selecting participants, observed that ‘it was likely to yield a particularly homogenous group’ (Lawler, 2000, p174). This was true of this group who offer little diversity in terms of ethnicity, class or social group. I know three of the women in other settings, but all are people that I might potentially have met socially. Nevertheless I found that there was considerable variation in their nationalities, family backgrounds and family structures (see participants on page 65, Biograms in Appendix I and interview transcripts Appendix VI).

As I see myself as belonging to this group of women, I have some personal insight into the culture, motivations and attitudes that provide the context from which their narratives arise. To understand some of the characteristics of this group I consider the implications suggested by the criteria for participation (as set out on page 65). I start with a brief consideration of where participants were placed in the history of family change.

Age of Participants – Historical Context

I was a teenager in the late sixties. The world was just bursting apart with changes, questions and different ways to live and I had choices that my mother and previous generations didn't have....Born in 1954 I grew up in an era where there was a mismatch between what we were told and what happened in reality to women, perhaps more clearly than at any other time. We were being told that our future was marriage, being a wife and having children. Alternative role models were few and far between and were seen as outlandish and outrageous (Elaine).

The above extract from Elaine's interview is relevant for most of the women who participated; all were over forty years of age; the youngest grew up in the late nineteen sixties and the oldest in the late nineteen forties. This was the end of a

period (before 1900 - 1970) that was a highly conventional period in family terms (Allan, Hawker et al., 2004, p302). It was the time when nuclear families were the norm. Marriage was an expected and morally accepted path for men and women; ‘a lifelong institution that committed individuals socially, economically and legally.....governed by relatively rigid rules [and] sanctioned through religious and social codes (Allan, Hawker et al., 2004, p303)’. From the late sixties family patterns began to change and ‘a common model of family experience could no longer be assumed’ (Murphy and Wang, 1999; in Allan, Hawker et al., 2004). Developments that have taken place since then have involved ‘new understandings between the relationship between sex, marriage and child bearing’ resulting in ‘the realms of family practices...[becoming] more blurred’ (ibid, p.314).

A catalytic factor at the start of these changes was a reform of the divorce laws in 1969 (see Robinson and Smith 1993 for a detailed history of the change in divorce law). Prior to that it was difficult to divorce as the petitioner had to prove that the respondent had committed an offence ‘such as adultery, cruelty or desertion, for three years (Robinson and Smith, 1993, p12)²⁸. However from 1969 irretrievable breakdown became the key criterion for divorce. This change emphasised relationship quality, as a key criterion for divorce (Allan, Hawker et al., 2004) and therefore for the first time implied the right of both men and women to be happy within their marriages.

This history provides an important context for what was taking place in participants’ lives. They were starting their families at a time when women had recently become able to be financially independent from men and to leave unsatisfactory marriages with relative ease while cohabitation was beginning to be an acceptable situation. As stated by Allan et al ‘[women’s] dependency on men as partners and husbands has altered in ways that have had profound impact on patterns of couple, family, and household solidarities’ (p312). Thus the participants, when raising their families had different options than their own mothers had when raising them. However the

²⁸ At that time, death of a parent was the most common reason for a stepfamily to exist, in keeping with this, two participants who had stepmothers did so because their mothers had died and their fathers remarried.

influence of their upbringing at a time when different sets of values were the norm are possibly be reflected in the fact that all but three participants married their children's fathers. This was despite this group consisting of liberal, unconventional women, who were moving in circles where cohabitation would have been acceptable.

The Effects of Trauma

As all the mothers I interviewed had raised their children in a stepfamily situation, it might be expected that they all had the experience of leaving, or being left by, their children's father. Most women described prolonged difficulties and/or shocking endings to their relationships. There were two exceptions to this among the participants: Elaine – a woman who was vehemently anti-marriage – lived with her son's father and had no other children; Mary left her daughter's father before she knew she was pregnant.

I quote Allan et al.(2004) on the ending of relationships:

The breakup of relationships is ...usually problematic. There may be more acceptance of it as a solution to relationship problems, but it nonetheless frequently generates major difficulties for those involved.Ties established over time, involving shared property, imagined futures and a deep emotional commitment are rarely ended without disharmony, pain and friction, sometimes over a long period. Such difficulties are clearly exacerbated when...dependent children are involved. (p309).

There was considerable shame expressed by some mothers who had been left by their partners, and by others on their difficulty in very bad situations. The difficulties some women found in leaving their spouses may in part have been an expression of the conflict between a desire for the relationship to succeed and endure, and the need for and belief in the right to individual fulfilment as women and *mothers*. The fact of their marriages suggests the intention of making a lasting commitment. The impact on the mothers of the breakup of their marriage must have had an effect on how they related to their children and is likely to have been an

influence on that relationship, possibly intensifying the feelings between them (as suggested by Derek Portwood during my presentation of this work) ²⁹.

The Passing of Time

Importantly because of their age and the fact that their children were now either late adolescent or adult, there was a trajectory through time in participant's narratives. Their stories were of past events in their mothering lives. As I had hoped, they were able to look back at their lives and make sense of situations, some of which had been chaotic and painful. They were also able to pride themselves on situations and behaviours that had worked in creating happy stepfamilies.

It was apparent that despite many challenges within their stepfamilies most participants were now in a place of stability and contentment.

Nationality and Colour

I want to note that despite the fact that all women were white and could be seen as living within closely connected social groups, this does not imply cultural uniformity in their families of origin. The women represented a diverse mixture of cultures and nationalities. Two were second generation of Jewish immigrants as am I – a large representation for this small sample and two other women were raised in another country. Thus out of eleven women, more than a third had non-British ancestry with either themselves or their parents having immigrated to this country. Those women whose parents were immigrants grew up with parents who were managing the loss of their home country and having to make their way in this country. Those women who had themselves moved to this country had left their original home and were living within a new, albeit related, culture.

Sexuality

Another consistency among the participant sample is that they were all heterosexual.

²⁹ Derek Portwood suggested that trauma caused by the ending of the relationship with their children's fathers might intensify the mother's bonds with their children. Perhaps guilt or other feelings caused by the trauma would bring them to relate to their own children differently than in a nuclear family. Possibly if things go smoothly in a family, the issue of biology would be taken for granted.

Thus gay or lesbian headed families who are likely to share some of the issues raised within these pages, were omitted. Gorell Barnes writes:

When a woman forms a second relationship with another woman rather than a man, many of the preoccupations a couple bring are to do with whether the children are reacting to the lesbian relationshipor whether the anger the children are showing is a feature of post-divorce family behaviour and stepfamily life (Gorell Barnes, 1998, p133).

Issues to those that arise in stepfamilies are also present in families where children have been adopted, but there are crucial differences. For example, while in stepfamilies there is usually a relationship chosen first and children are part of that, whilst in adoption children are chosen by the parents. This is also true for gay and lesbian families.

Social Culture /Life Style

A contributing factor to the participants' family styles was their social culture at the time of beginning their families. I shared with several participants an 'alternative lifestyle' meaning that we were part of the 'hippy' movement in the sixties. Those participants who were not 'hippy' were nevertheless influenced by the questioning of traditional society that was taking place during the late sixties and early seventies.

My own experience as part of this group is of a passion in common with many other people of my generation, for a lifestyle that was personally satisfying and which challenged traditions held by people of our parents' generation. Thus I was among others in searching for personal fulfilment. The fact that all the other mothers I interviewed were part of the same movement to some extent is evidenced by stories of their unconventional lifestyles, taking up of educational opportunities, artistic and social careers. As part of this, I and several other participants were involved in a search for spiritual fulfilment outside of given religions and we found during the interviews that we had been involved with the same spiritual teacher when we were younger. The interest in psychotherapy and counselling that was held by five members of this group including myself, can also be seen to as part of a search for

self-fulfilment and an interest in the stimulation and promise to be found in self-exploration.

It might be considered therefore that this group of women were likely to seek satisfaction through their relationships. They might also be acutely aware of situations that made them feel unhappy and seek to find solutions to this; they had the opportunity of doing so. In other words, this was a group of mothers who believed that there were solutions to unhappy lives and who had options that enabled them to look for happiness in their relationships, living circumstances and careers.

In their present day lives the participants could be seen within three distinct groups – with some crossover. The first group would be those women who are counsellors and psychotherapists; there were five of these (including myself) and one who had experience of being in counselling and psychotherapy. These women had the strongest concepts about psychotherapy and might be said to share a ‘psychotherapy/counselling culture’.

The second group would be those who work in the social or voluntary sphere, There were two – and one crossover, in that she worked as a counsellor in the voluntary sector. The third group consisted of people who were artists or self-employed, part of an alternative community in a rural area of the country. This was the most ‘alternative’ group. I see myself as fitting into all these categories to some extent.

Thus the participants were able to provide a unique history of stepfamily life, from the perspective of groups who were exploring alternative ways of living. They were among the first generations of women to experience the relative ease of divorce reform and therefore might be described as pioneers setting the path for future stepfamily situations.

As they were among the first group of women to be following the types of paths their families took there was very little – if any – support for their stepfamily situations. Their narratives can therefore be seen as women forging their ‘family careers’ (Allan, Hawker et al., 2004) in previously uncharted territories. The participants were therefore women who *had* to improvise in these circumstances

using their instincts and creativity to negotiate the situations they found themselves in. Their stories describe challenges and satisfactions of stepfamily life that continue to be relevant.

Limitations

Because the sample of women I interviewed constituted a small and in some ways similar group their narratives cannot be used to make general assumptions about the wider population of mothers in stepfamilies. The findings tell us about *this specific group* of women whose words have been processed by *this specific researcher*.

This research sample provides no information on women outside of this limited group i.e. of working class or upper class situations, immigrant groups or sexualities. There is no information here either on women who were more conventional in their life styles. This suggests that there is potential for research that might compare the experiences of mothers in different cultural or ethnic groups. Such a project might identify whether there are aspects of mothering experienced across all groups irrespective of culture.

Because the data was of remembered stories told retrospectively, they are a reconstruction of the truth rather than the truth per se. Therefore they provide no information from people who are dealing with young children in stepfamilies *now*. There is therefore indicated in this a potentially valuable research project developing interventions *with* people who are currently experiencing these difficulties.

Biases of the Interview Process

The Influence of the Interviewer

I have previously described how being a mother who raised children in a stepfamily situation linked me with other participants and was the premise on which I selected participants. I focus here on how being and *being seen* as a psychotherapist might have influenced the stories I was told and therefore the type of outcomes I was likely to find.

A feature of this project was my involvement in every aspect of the research (Moustakas, 1981; Belenky, Clinchy et al., 1986; Etherington, 2004; Barber, 2006). Thus I was the primary research tool (Moustakas, 1981; Kohler Riessman, 1993; 1994; Sparkes, 1996; Cresswell, 1998; Barber, 2006), the designer and implementer as well as subject. When analysing other's words and narratives I considered my feelings, judgements, opinions, discomforts and comparable experiences to provide information and as writer I added accounts of my own story, thoughts, and feelings and did not shy away from using the first person. Thus biases arising from my experiences as a mother, psychotherapist and other identities I hold are woven into the fabric of the findings.

As Kohler Riessman (1993) points out, when researching human experience, every stage is influenced by the self of the researcher. In attending to *my* experience I make choices about what I notice 'from the totality of the unreflected on, the primary experience' (p10). Additionally the stories of participants' experiences might have differed in the telling, if someone else were doing the listening. '....in telling about an experience, I am also creating a self...how I want to be known' (Kohler Riessman, 1993, p11). Even transcription is not free from bias as:

whatever form of taping [is] used, [it would] ultimately have to be represent[ed] ..in some kind of text. The choices that the transcriber makes being e.g. whether to include 'silences, false starts, emphases, nonlexicals like "uhm," discourse markers like "y'know" or "so", over-lapping speech and other signs of listener participation in the narrative (p12).

In accepting these points I recognise my biases as being hugely influential on the data with my story is to some extent superimposed on that of the participants. Furthermore, the roles that participants' have perceived me to be are likely to have skewed their narratives towards what they believe that I would like to hear.

Therefore it is crucial to any interpretation of the data to recognise that I was looking at the data through the lens of my own psychotherapeutic perspective and that my presence as an interviewer was not neutral to participants. One effect of this may have been to tend me towards perceiving stepfamilies as more problematic than they

are, as stepfamily members I meet in my work, will have sought me out because they have difficulties. People who feel they are managing well are unlikely to ask for help from a psychotherapist.

I presented myself to participants as primarily a researcher, and was careful not to be conducting a psychotherapy session rather than an interview. I used psychotherapy skills throughout the interview. As described on page 72 I interviewed using psychotherapeutic methods. These were intended to help participants tell me about areas of their experience that they would usually not reveal; especially to a relative stranger. My interview style was likely to account for participants having provided detailed accounts of difficulties and feelings that they may not have otherwise accessed. It might also have emphasised my psychotherapy persona, and have caused them to unconsciously *skew* their narratives to give me what they thought I wanted to hear.

In their perceptions of me as a psychotherapist, participants' concepts of psychotherapy would have come into play. They might have assumed that a psychotherapist researching stepfamilies would want to know about what was wrong, rather than what was right; they might have thought that I would want to hear about their problems because that is what a person talks to a therapist about. This is not my view of therapy or what I do as a therapist, but it may well be how another person would perceive me.

Those participants who were also psychotherapists or counsellors or had been in therapy themselves shared some part of a 'psychotherapy culture' with me. They were likely be familiar with talking about their inner worlds and would probably imagine that this was what I wanted to find out about – and this would have been correct. Therefore there would have been a correlation between their perception of me and the information I wanted to elicit. At the same time the bias of their different therapeutic orientations and their personal motivations for taking part would have also contributed to the stories they told.

Why Participate in this Study?

As all participants offered to take part, and two actively sought this, I consider some

of their motivations and how this has influenced the interviews. It seemed that there were questions that some participants wanted to answer about their own stepfamilies, and for a couple of women it seemed that the interview was seen as the opportunity for a focussed psychotherapy session. Sally talked to me for three hours – (longer than a psychotherapy session usually is), and told me in that time the story leading up to the discovery of her daughter being abused by her ex-partner. Amanda told me over two interviews her experience with her ex-husband's partner – her children's stepmother and how she (the stepmother) had influenced Amanda's relationship with her daughter. Robin's motivation seemed to be pride in her extended stepfamily that included Barbara. She was interested in Barbara's perspective on one of the stepchildren in that family. Bella wondered about the character change of her second partner. Other participants may have had similar motivations that were less apparent.

There were references during the interviews to psychotherapy and me as a psychotherapist that revealed how psychotherapy was seen by some participants. For example Esther referred to therapy while describing her difficulties in getting attention for herself. Bella talked to her daughter about her father for the first time inspired by my coming³⁰.

Overall there is no doubt that the knowledge that I was a psychotherapist must have influenced the type of material people chose to reveal. The participants' overall descriptions of complicated relationships and difficult situations were an outcome of, among other things, how I conducted myself during the interviews the areas of interest I followed and my perception of participants combined with how they perceived me, their personal interests and unconscious perception of what I wanted from them. The fact that in most cases I felt very satisfied with the material the participants covered may therefore have been in part a confluence between us.

³⁰ It is unclear whether this was influenced by my being a psychotherapist or whether she became curious to think more deeply about the theme. Perhaps her concept of psychotherapy was of looking into things in a way that she didn't usually.

This project cannot answer the question of whether bias in the research findings towards difficulties in participants' stepfamily situations is reflective of this participant sample, my influence as a therapist or represents the general experiences of mothers in similar situations. However, from my experience as a psychotherapist I can say that people often tell me that they are surprised to be talking to me about difficulties in their relationships which they have never discussed with another person. The suggestion is that in our culture, people do not easily talk about problems or show those areas where they are struggling therefore appearances to the contrary might be deceptive.

Relevance of Exploration

A criticism that was made of this project at a conference presentation for EAGT (see Appendix IV) was that there is a basic flaw in thinking about stepfamily dynamics through the lens of one relationship. This criticism was based on a systemic approach which emphasises the family group as a system and therefore family therapists focus on connections between people, patterns of interaction set up over time and expressed in speech, beliefs and behaviour (Gorell Barnes, 1998).

While I subscribe to a systemic view of family relationships I do not accept this as valid criticism of this project. Systems are made of individuals, and the project focuses in on the *contribution* that mothers make to the family as a whole. Thus focusing on mothers, cannot provide an overall view from all perspectives of the stepfamily. It does however fill in the detail of one part of the whole.

I explain this further through brief consideration of behaviour in therapy groups. As discussed in chapter 6 (page 185), members of therapy group are involved in a network of connections and interconnected behaviours and in this way operate as and for the system. They are also individuals who have their own experiences and make choices. In my work as a therapy group leader, I find individuals within any group (including family groups) are constantly dealing with this dynamic i.e. of being both a member of a group – in the service of that group – at the same time as being an individual – in the service of their own selves. This seems equivalent, (albeit on a larger scale) to how women who participated in this project experienced

themselves as mothers. On the one hand their actions and concerns related to their children - the mother and child dyad, they were embedded in a stepfamily dynamic and were also independent women outside of mothering with actions and concerns related to their personal desires and fulfilment.

An approach to this research which has been suggested by several people, would be to explore the dynamics within a whole family. If I had done so I would not have been able to compare different individual experiences of mothers. Such a study would have provided different data and would answer questions more related to the whole family group.

Early on I realised that I would be unable to present a full description of stepfamily dynamics by focusing on one part of the stepfamily 'cast of characters'. This was not my intent. The full picture of the family is a larger project. There is the potential for future research that fills in the details of other stepfamily characters. As other psychotherapists are focusing on different stepfamily roles, there is potential for future collaboration to bring this together.

Verification and Validity

As the fieldwork and analysis of the data was all done by me alone, the following question is relevant to this project: 'all field work done by a single field worker invites the question, why should we believe it?' (Bosk 1979 p. 193 as quoted in Maxwell, 1992; quoted in Kohler Riessman, 2008) Clearly what I have found must be verified as being more than heresay. Addressing this issue, Cresswell (1998) provides a list of eight forms of verification and suggests that at least two of these be employed (pp 202-203). The two of these that relate to this project he names as a) 'clarifying researcher bias.....[where the researcher] comments on past experiences, assumptions, biases, prejudices and orientations that have likely shaped the interpretation and approach to the study' and b) 'Member checks...[where the researcher solicits informants' views of the credibility of the findings and interpretations' (p202). I have applied both of these in this investigation.

Throughout the implementation of this project I have sent material back to participants for verification and for further comments. I have found that comments back from participants showed up biases that I was previously unaware of, as the question of how I might be skewing the findings has been the subject of correspondence with several participants. Checking back has also brought me to understand that what has been prominent for me and stands out for me in the text is not necessarily the same as what has been prominent for a participant. I find that the participants and myself have different biases from each other and as author and editor of their words my biases have come forward. This at times has led me to interpret text differently from the meaning intended by a participant³¹.

An example of how my interpretation differed from the way the participant intended is given in on page 162 which refers to Sally's comments on having read the Thematic Findings chapter of this document. I amended the findings to incorporate her comments and to show the potential for different interpretations of the data. Sally also edited the monologue narrative which is the version that I have included (Appendix I pages 358-390). She made the following additional comments on her reflexive process and highlights the different foci that she had as participant and I as researcher.

.....[reading the monologue and thematic findings] made me realise that I had never quite finished my own personal re-writing of the narrative that you sent me. I had done most of it, so I was able to finish it in the last couple of days. Some of this re-writing does actually correct some misunderstandings that were apparent when I read through it.....Thinking that this is something I may be sharing with some people, I added headings to divide it into six parts as well.

³¹ This observation relates to an aspect of Gestalt field theory which recognises that a figure arises from the field according to the needs of the perceiver. The example given in 'Gestalt Therapy' (Perls, Hefferline et al., 1951) is of a thirsty man in the desert; if he sees a glass of water he is unlikely to see anything else until his thirst has been quenched. Thus his thirst makes the glass of water figural to him. A person who is not desperately thirsty may not even notice the glass being there

I had other feelings re-reading the narrative. It called to mind you saying that mine was the longest of the interviews. At the time I remember feeling a bit embarrassed and wondering why. On re-reading it I can see how much detail I went into about my experience in places, like a vivid recall of some details, and how I did use the interview to tell a long and complicated story in a sustained way that I would not normally do in any other context, including therapy.

During the interview, the theme that seemed uppermost when we talked about my experience was a theme of loss of control and of the impact of having two fathers, in a sense on the two older children. I'm interested these themes didn't really come up [in your writing] (Sally).

While these themes were forward in Sally's mind, I found very little specific detail of them in her narrative. There is therefore a discrepancy in what she remembers being in touch with during our interview, and the detail of what she talked about³².

Esther also wrote back after reading the monologue of her interview and the thematic findings. This became an email conversation in which both of us changed position through responding to each other. In the following extracts it can be seen that both of us changed position through our contact with each other.

Esther (Letter)

Having read thematic findings, I felt my words being slightly twisted to fit your argument, but I know this happens with qualitative data. I suppose I feel that the quotes that have been used miss the point of what I was saying in those parts of the interview and that other parts are omitted which would have genuinely illustrated the argument you were making.

For example, I felt slightly hurt that you did not use my story to illustrate 'women who genuinely accepted their stepchildren'.

Perhaps it is that my personal themes – like the joy of having step-daughters simply do not fit with the findings you chose to focus on,

³² This is curious because Sally received a copy of the transcript as did all others.

Claire (email response)

I have been trying to get hold of you because of your comments that I had twisted your words to fit my argument. I would like to know where you see this, as my intention is to be accurate to your meaning and to do your story justice. Likewise you say that there are parts in what you said that would have illustrated an argument and that I have missed. If this is clear to you anywhere I would appreciate that as well.

Esther (email)

I did not mean that you had twisted my words but that you had extracted bits of data to weave into the stories you wanted to tell about stepmothering, including your own. Inevitably in the process of finding themes (or imposing order) on data, one inevitably 'tunes in' and emphasises certain hues over others. My main feeling was that in order to make your point that the bond with your own children being of an entirely different (more visceral) quality you underplayed the pleasure I expressed and the significance for me of my stepchildren, especially the girls. I was surprised that you could not find a better/richer quote than the following: 'I've had stepchildren all my life. Talking about the stepchildren bit is fine, its talking about my son that brings the tears up' and 'Henry had a daughter which of course was lovely for me'.

Inevitably there were sections where I thought "Oh, why didn't you includes something from what I said?" But this is just how it is.

One tells one's stories and in one's own narrative things get lost. Then when someone else takes them and uses them to create another narrative, of course things get lost and reduced in some way.

Claire (email)

Thank you. I really appreciate these comments. I realise that we talk from two different perspectives – I as researcher and you as participant. What strikes me is the difference of telling a story and of receiving it, and of how what stands out for you might not for me and vice versa.

I was mostly interested in mothering which is probably why I wrote very little about stepparenting except in contrast to mothering. I

thought that the fact that talking about your son brought up tears for you was profound. I also felt very moved by your descriptions of mothering as a loss. I didn't pick up from what you said how significant having girls was for you.

Another time I would do this differently and follow up from the first interview to collect some of these important points and others that I was curious about.

Esther (email)

If you interviewed me today I might weave a slightly different story. I've become very attached to my stepchildren – or have prided myself in being emotionally involved with them and feeling proud of them. And would like to think that I have been important to them – but realise that I am probably not as important as I would like to be! My feelings around my three step-daughters are inevitably coloured by the fact that I did not have daughters and had two abortions. In some way I feel I have left over mothering energy. So in a way it supports your argument in that my feelings about the girls and the importance of them to me is in the context of not having one of my own.

This dialogue shows the different perspectives and biases held by myself and Esther. For me, Esther's tearfulness when she thought of her son as opposed to her stepchildren beautifully illustrated the essence of difference between being a mother and stepmother; that is my bias. She saw that I missed how special her stepchildren and stepdaughters were. Our conversation enabled us to recognise each others' perspectives.

I have since revisited the writing to ensure that Esther's perspective is accurately represented (on page 142). Her response to this is as follows:

This sounds great as does the analysis after it. Much more reflective of what I was saying and not saying.

The interaction between Esther and me also illustrates the sensitive nature of this work; in interpreting another person's story according to my own bias there is the potential to misrepresent them and be unwittingly hurtful. It can be seen that through our communication new information came to light. The final message from

Esther reveals an understanding that had not been visible before. The dialogue has enabled the outcome to be co-created and suggests new themes that I would have otherwise been unaware of.

Issues of Validity

This section considers how an investigation of this type might be validated. Because the narrative nature of the findings suggested possibilities rather than confirmed hypotheses, certain methods of validation do not apply. For example it does not make sense to seek its validation through a control group. As Kohler Riessman (1993) states

....prevailing concepts of verification and procedures for establishing validity (from the experimental model) rely on realist assumptions and consequently are largely irrelevant to narrative studies (p64) .

(Procedures that were being vociferously argued for when this was written over sixteen years ago may now be more readily accepted than they were then). The criteria by which this project might be validated is discussed further in the next section.

The strengths of this project are its evocative inside view of mothering in stepfamily situations, its contribution to understanding the experiences of mothers in stepfamily situations and the questions it raises about the contribution of biology and attachment to stepfamily dynamics. It is a project strong on description and reflexivity and this is commensurate with the paradigm of psychotherapy and its concerns with human experience.

Kohler Riessman writes:

.....ways of thinking about validity and ethics are products of the paradigms that spawn them....the validity of a project should be assessed from within the situated perspective and traditions that frame it (Kohler Riessman, 2008).

Sparkes (2002) suggests ‘[radically] reconceptualising or reframing the notion of validity to judge different forms of enquiry’ (p201). He quotes Lather (1993) who

writes on ideas of transgressive validity including ‘*ironic* validity, *rhizomatic* validity, and *voluptuous* validity (Sparkes, 2002, p203). In summary she is proposing validation that is responsive to the methodology of the research and intentions of the researcher. Sparkes also proposes a creative approach to validation that is relevant to the inquiry in question. These suggestions seem to be a response to the plethora of increasingly creative and diverse qualitative methodologies that is the hallmark of contemporary research in psychology, social sciences and psychotherapy.

If I apply Riessman and Sparke’s proposals on validity to this project then the following criteria arise as relevant to the feminine, Gestalt, phenomenological, narrative psychotherapeutic contexts within which it is set.

- * **authenticity;** by which I mean that it has a quality of congruent personal truth
- * **reflexivity;** by which I mean that I have been transparently present as a researcher participant and reflect on the meaning of my experience,
- * **responsivity;** that I have been able to respond to meanings within the data rather than impose a rigid view.
- * **dialogic;** in that I have worked in collaboration and communication with participants, allowing my view to be influenced by theirs, and for theirs to be influenced by mine. (Including a demonstrated willingness to be influenced by participants’ rather than being rigid in sticking with my bias and opinions).
- * **useful imprecision and confident tentativeness;** These concepts are important within a psychotherapy such as the one I practice, that works in part through lightly held suggestion and imprecise guessing, inching towards a *meeting* and *understanding* between two people.
- * **embedded ethical awareness;** an ethical sensibility that is embedded within the relationships connected with all aspects of this project.

- * **usefulness;** in its contribution to the field of psychotherapy, in theory, focus and action.

These are qualities that speak to my intentions for this project. I suggest that through using these criteria it would be possible to say whether those intentions have been achieved.

Contribution to the Field

The psychotherapy field within which I am placed is that of Gestalt, which sits within the broader category of humanistic psychotherapy within the field of psychotherapy as a whole. As I have been disseminating this project in the form of workshops at conferences, it is within the first two of these professional contexts that my work is becoming known. There are two strands to the influence of my work in the field. The first is educational and theoretical: I have created an awareness of the prevalence and relevance of family change for the general population among humanistic psychotherapists, I have stimulated interest in stepfamily dynamics through my research on mothers and my perspective on the importance of biology in understanding stepfamily dynamics and have founded an organisation dedicated to furthering research and work with stepfamily members. The second is as a psychotherapist conducting research to further my knowledge and work.

A Clinical Example

In order to present how this project contributes to actual work with clients I provide a brief and simplified description of my work with Emma, a mother who has two stepchildren from her partner's previous relationship.

Emma's is married with a daughter of her own and two stepsons. Her stepchildren live with her every other weekend and during holiday periods. She talked to me about her situation as she was distressed to find herself dreading the time that they came to stay and the extra work they entailed. This was despite her intention of being a good stepmother and liking them as individuals. Part of the difficulty for her was that when they were around she

felt left out. This caused her to become more of a unit with her own daughter, so that the family tended to divide into her partner and his sons and herself and her daughter. She had a very distant relationship with her stepson's mother, and felt that there was much that was unhealthy about how they were raised. An example of this was the amount of television they watched. She found it very difficult to talk to her partner about this as he became defensive of his children. As a result she often found herself feeling angry and resentful when her stepsons were around.

I have approached these difficulties from several perspectives informed by my research. I have said that her feelings towards her stepchildren are not unusual, stepmothers often feel resentful. This normalising of her feelings helped her to be more relaxed about them and instead become curious about what was evoking her resentment. This led to a more psychological exploration of the specific things that were annoying her about her stepchildren; she found the older child particularly difficult. From this she recognised that she felt indignant that her stepchildren were allowed to do things that she hadn't been as a child. Furthermore she found that she was relating to her eldest stepson as if he were one of her siblings. When she saw these things she was able to access a more mature place in herself and feel warmer towards him.

A further aspect of our work has been the uncovering of her very high expectations of herself and everyone else. Slowly, she has begun to experiment with lowering these, making less demands on people and recognising her need for acknowledgement.

Emma has recently reported that her life with her stepchildren is becoming easier, she feels less resentful, she is more able to accept them. Importantly, by recognising her own biases she has found that she does not need to think of them as 'bad' when they are different from her. She has also begun to consider approaching their mother and trying to build some communication between them.

The broad themes of this work represent a model of working with individuals in stepfamilies that support them to find ways through difficulties. There are specific

areas to be examined; for mothers these include personal history, stepfamily history, expectations of self-as mother and self as woman in own right, cultural expectations and relationships with ex-partners, current partner and step-children's mother. Thus out of this research I – and members of StepIn ASAP- are developing a model for working with stepfamily members.

Another contribution to psychotherapy has arisen from the development of tools and exercises that explore the biological relationships in stepfamilies i.e. Biograms and role play. Biograms provide a visual map that people have claimed helps them to see the connections within their families with more clarity. Role play enables people to explore dynamics within a group, providing a version of the family set-up and allowing for safe explorations of different actions and behaviours. These are *explorative methods*. Clients and therapists both have found that they can use these to open up dialogue and view dynamics and situations from new perspectives. A further 'spin-off' from my exploration is the impact on work other than with stepfamily members, especially the use of the stepfamily as a metaphor for group dynamics.

The explorations of my research provide a map of happy and less happy stepfamily situations successful and ways people have navigated their situations. It has shown areas that mothers in stepfamilies are likely to be dealing with and has highlighted the importance of biological relationships in stepfamilies.

The Prevalence of Stepfamilies

Occasionally I have asked people in psychotherapy training workshops or groups that I am running to raise their hand if they are, or have been involved in a stepfamily situation. Usually about two thirds of the group raise their hands. Additionally there is often someone at these events who realises for the first time that they are in a stepfamily, or about to be in a stepfamily. While it is likely that a high proportion of people in stepfamily situations would come to my workshops, this was also the case when I presented to an entire counselling service that was nothing to do with stepfamilies. It seems therefore that there are large amounts of people affected by stepfamily situations, which means that psychotherapists and counsellors

will be meeting them in their work. In this country I am not aware of anyone in the Gestalt field focusing specifically on stepfamilies either in research or in their practice. Therefore my work is filling a gap.

A Forum for Taking this Work Further

The organisation I have founded 'StepIn ASAP; Advancing Stepfamily Awareness through Psychotherapy' is the only London based psychotherapy organisation that focuses on stepfamilies and psychotherapy work with stepfamily members. We are working with the objective to develop knowledge, theory and skills so that we can effectively support people in stepfamily situations. Additionally we are working towards promoting the recognition that stepfamily issues are important and relevant to current client groups among our peers. To do this we are encouraging psychotherapy training organisations to include family and stepfamily issues included in psychotherapy in their curricula as well as putting on continuing professional development workshops.

Collaborative methods of learning and teaching are not being applied to stepfamilies by any other group of people that I know of. This project therefore is unique. It has the potential to grow. My vision is that eventually we will be able to develop a network of people throughout the country who will be able to work with stepfamily members and run similar groups and workshops.

As an addendum to this section I note that my contribution to the field has not been one of providing answers to stepfamily problems but of bringing forward the importance of biology and providing means of exploring this that would support clients to find answers for themselves. I have therefore *not* developed means of measuring success at this stage, as this does not fit with the paradigm within which I work. There is therefore indicated the potential for future research projects which would identify the efficaciousness of different methods of psychotherapy work with stepfamily members; i.e. which forums were most useful, groups, individual, couple or family; and which interventions are the most useful.

Developing Practitioner Research

The second strand of my influence in the field is as a practitioner/researcher. I have

contributed to developing research in human experience that incorporates psychotherapy methods and philosophy and produces findings that are of value to psychotherapists. I have ensured that research has a platform at important Gestalt conferences (EAGT 2007, BGS 2008, UKAGP 2009). My work has encouraged others to take up their own research projects and face the challenges that doing so presents.

Many Gestalt practitioners seem to be research averse; evidenced by finding research presentations being squeezed into a lunch-break during a recent UK Gestalt conference, with only four delegates – out of over a hundred - being attracted to a workshop on research. However I am one of an increasing number of gestalt and humanistic psychotherapists who have chosen to do their own research and writing and who are seeking to encourage more interest within the Gestalt community. Thus the venture is one of bringing the expressive creativity of humanistic psychotherapy, together with innovative research projects that test and validate our practice.

Conclusion

In focusing on the experiences of mothers and the nature of biological relationships within stepfamilies, this project has addressed a relatively unexplored area of stepfamily living. It highlights the significance of biological relationships within stepfamilies, and the centrality of mothers. The need for further research of this type was noted in an earlier review of stepfamily studies (Coleman, Ganong et al., 2000). This has been addressed by Cartwright and Seymore in their research which focuses on parent child relationships (Cartwright and Seymour, 2002; Cartwright, 2008; Smith, 2008). However I have found no research that focuses on the experiences of mothers in their own right (as this project does) rather than on the challenges of parenting. Therefore there is room in the field for research of this type. The Gestalt-framed, phenomenological and narrative methodology I have used has uncovered some of what mothers *feel* in their stepfamilies, how they have made decisions, what is beneficial and what is difficult in these situations. I suggest that

findings such as those this investigation has produced are valuable for psychotherapists and counsellors who work with *how* people experience and construct their lives, and support them to become more fulfilled in their family situations.

As examples in Chapter I show, it is not straightforward to define stepfamilies as definitions vary according to who is making them and for what reason. They range from being very inclusive i.e. any family or situation that involves children from a prior relationship, to being so tight as to only recognise re-marriage – not cohabitation - as being the basis for calling a family a stepfamily. Furthermore people self-define in different ways. These issues perhaps explain why people often haven't recognised their family situation as a stepfamily until they have come to one of my workshops or groups.

The archetype of the 'wicked' seems to overshadow the fact that biological parents can also find their stepfamilies difficult. Researchers have identified archetypes for both mothers and stepmothers that make their respective stepfamily positions difficult; mothers are supposed to be self-sacrificing for the sake of their children, nurturing and loving, while stepmothers have to contend with a large number of stories about their wickedness (Coleman, Troilo et al., 2008).

As a mother myself I have become interested in how mothering influences and is influenced by a stepfamily situation. Research on mothers has found them to be central and influential in stepfamilies and this correlates with my experience and the descriptions from the mothers I interviewed. I suggest that in order that psychotherapists understand what is happening within stepfamily dynamics they need to recognise what is happening to mothers in these situations; how they experience their families, their expectations of themselves, and of their relationships with other family members.

It is curious the extent to which mothers in stepfamily situations are overlooked. I have repeatedly found myself having to emphasise strongly that I am interested in *mothers* not stepmothers, as the instant stepfamilies are mentioned people think of stepparents. This was even the case with one participant, who after having met with

me and discussed my area of interest still thought that I was interested in her as a stepparent rather than as a mother. It was as if mothers, although central to most stepfamily situations, were not being seen by people so that in focusing on them I have begun to make them more visible.

Possibly the issues faced by mothers in stepfamilies are not thought about, in part, because of how mothers are perceived by others and how they perceive themselves. As Lawler (2000) notes of the women who took part in her study of mothers and daughters:

[they] presented their position as mothers as one in which their daughters' (and sons') needs 'came first'..... The women tended to cast this situation in terms of their children's needs versus their own desires.... Most women saw putting one's own desires or interests first as the mark of a 'bad mother'(p153).

And Robin who participated in this investigation said:

Part of my career a long time ago was working in prisons with women who were serving custodial sentences in Holloway. A lot of those women were mothers and the kind of negativity and opprobrium with which women who break the law are treated is much.....more judgementalthan male criminals.....Somehow they're worse because they're separated from their children.....because they've ended up in a situation where they aren't able to carry on with that nurturing relationship, because they are physically separated from their children.

It would seem that mothers are supposed to love and care for their children before any other considerations and if they don't are judged to be a 'bad mother'. Such conceptions could get in the way of recognising the possibility that stepfamily situations may affect that relationship. i.e. nothing is supposed to get in the way of mother's ability to put their children before themselves.

From my own interview I realised that I felt ashamed of putting my own interests before my children's and saw the act of separating from my first husband and entering a new relationship as an example of so doing. It seemed from other

interviews that many participants were also ashamed or felt inadequate around some aspect of their mothering. This was not necessarily connected with being in a stepfamily but about their mothering qualities.

Among the explanations that have been made for the phenomenon that stepparenting relationships are different from parenting relationships, evolutionary Darwinian proposals are controversial (discussed in Chapter 2 and Appendix III on page 452). Daly and Wilson (1966) propose that it is a biological imperative for parents to favour their children and for stepparents to have at the best little interest and at the worst to be hostile towards their stepchildren. As they state in the conclusion to 'The Truth about Cinderella'

There is a strong rationale for expecting that the evolved human psyche contains safeguards against allowing a mere stepchild, however appealing, easy access to that special mental category occupied by genetic children, the appropriate objects for the most nearly selfless love we know (Daly and Wilson, 1998, p66).

I have discussed arguments against these theories in Chapter 2, on page 29.

I find that it is useful to take from the Darwinian view an acceptance of there being an inherent special-ness in the parent/child relationship that was absent in the relationship between stepmothers and stepchildren. The women did appear to have a 'special mental category' towards their children. They give examples of difficulties with stepchildren but also many examples of a developing warmth and inclusiveness towards their stepchildren. It seemed that while biology provided an explanation for the *difference* between step-relationships and mother/child relationships there were other contributing factors. Examples of these were the length of time stepparents and stepchildren had known each other, and the attitude of the non-resident parent towards the stepparent (Coleman, Troilo et al., 2008).

Overall my investigation into mothers' experiences uncovered a tendency for them to be overlooked as important and yet they were key stepfamily members. I found that mothers were underrepresented in research and that it was difficult to get across to people my area of interest. The women I interviewed were central characters

within their families, most continued to be the primary carer for their children. As a group they demonstrated strength, resilience, hard work and a commitment to the wellbeing of their children but not to the extent of total self-sacrifice. They were also pursuing a good quality of life for themselves and this was a consideration along with the needs of their children. I see the monologue narratives and thematic findings I created, in which I preserved the actual words of the women I interviewed, as a contribution towards making mothering issues in stepfamilies *visible*.

Future Directions

As this project has only looked at the experiences of mothers in stepfamilies I have filled in one corner of a much larger picture – that of the whole stepfamily. If the perspectives of other stepfamily members were included i.e. fathers, stepfathers, stepmothers, children and stepchildren, then there would be a complete picture. This would potentially provide a map that would support psychotherapists to understand the important issues for people in every stepfamily position all stepfamily members and the stepfamily as a whole. It would also enable comparison between the roles and provide the perspective of how stepfamily members interrelate. Thus this research while being a discreet piece of work is at the same time partial.

In order to address this I am planning to collaborate with other researchers, and to produce a book that brings all of this together. I have been in contact with people who are focusing on fathers, stepmothers and children who grew up in stepfamilies to this end.

A research project to come forward from this work, which may be taken up by StepIn ASAP is the designing of an effective course for stepfamily members. The course would be aimed at helping people to manage their stepfamilies and to ease some of the stresses and uncertainties that stepfamily members might experience. The form in which such a course would take place would itself require research – some of which has started. For example we have found that people do not come forward for a single day's exploration, and that people are looking for facts and guidance within their families. Whether it is useful to mix different stepfamily

positions together, whether to focus on mothers, or stepmothers, or couples and so forth would need to be identified.

A pilot training group with participants who were prepared to offer detailed feedback on outcomes, what they found useful and what was not, using an action research methodology would be a valuable way forward for this.

StepIn ASAP

The seven members of StepIn ASAP are developing knowledge on stepfamilies through experiential exploration together. To do this we bring issues from our work and personal lives, explore them using role play, writing and discussion. (Personal accounts of StepIn ASAP members' involvement are included on pages 175 - 182). We are working towards putting on a conference for psychotherapy professionals on Stepfamilies either at in 2010 or early 2011 and are planning our funding application. The objective of the conference will be to launch an ongoing program that takes workshops on stepfamily issues into relevant organisations, e.g. therapy and counselling trainings, schools, and voluntary sector organisations. I have been in contact with Claire Cartwright from New Zealand who has been conducting qualitative research studies on parent-child relationships in stepfamilies and Patricia Papernow, who wrote the seminal book 'Becoming a Stepfamily', both of have contributed a chapter to the International Handbook of Stepfamilies. I am hoping that at least one of them, or perhaps both, would be able present at the conference. I have also been in touch with people researching stepfamilies in this country. Details of our plans are included in Appendix IV page 470.

As my work with stepfamily members, my program of conference presentations and other workshops continue, I have been making theoretical connections between dynamics in group psychotherapy practice and stepfamilies. It seems that a stepfamily metaphor is useful for certain situations that arise in groups such as boundary issues, dual relationships loyalty binds and sub-groupings. Recognising this correlation has been exciting and seems to be an entirely new way of thinking about groups. It has already proved useful in my work. I have described this fully earlier in this chapter (on page 199). I see the implications of these ideas as

challenging orthodox therapy group protocol, as a stepfamily metaphor supports the existence of confusing boundaries and dual relationships within these groups. When I first came across this idea it seemed to be an entirely new thought; I felt possessive of it and reluctant to tell anyone in case they ‘stole’ it. Now however this model is part of my ‘toolkit’ for running therapy groups and is recognised by StepIn ASAP members. Increasingly I find organisation and group situations for which a stepfamily metaphor can be usefully applied.

Personal Development

I have found that working on this doctorate has been all that I wished for when I started. It has been transformed both professionally and personally. I have succeeded in bringing stepfamily issues to the attention of the Gestalt world and there is a building interest in this. This doctoral project has also attracted interest both in this country and overseas and I have been in touch with key writers and researchers on stepfamilies worldwide and within this country.

In my work as a therapist a trickle of people are approaching me, specifically to explore their stepfamily issues. I find that with each new client or couple, I learn more about the issues that can arise in these circumstances. I see that in stepfamily situations problems arise from many different areas, not just those specific to stepfamilies. Through my therapy work I have found that people in stepfamily situations value their feelings being recognised and ‘normalised’. It helps a stepparent to hear ‘it makes sense that you feel that’ or for a mother to have her protective feelings recognised. With supervisory support, I have begun to work with young people from stepfamily situations and other members of their families, something that I would not have ventured to do before. Thus working on this project has expanded my area of work and has had a huge impact on how I practice.

This investigative exploration has produced rich results in its findings and has attracted other therapists to become more aware of stepfamily issues. The project ties together as a whole – I am amazed at this; I thought it never would. Aspects of my whole life and work are brought together within these pages. I am satisfied that

this work has created a step towards a deeper understanding of stepfamilies and a stronger interest in them among psychotherapists.

Personal changes are also more than I hoped for. I have identified blocks to my to learning, become far more confident and understand more about myself than I did when I started. I have learnt to constructively criticise, to be able to follow arguments and to write better. I realise that this has involved an aspect of growing up intellectually. It has taken time, but I now feel less easily swayed by other writers, and more able to think about my reactions and thoughts in regard to what they are saying. I am now more able to recognise what I understand and easily accept in their words as well as flaws in their arguments or statements that I disagree with; this is something I was not able to do at the beginning. Therefore working on this project has been a transformative journey.

I feel that this piece of work is my child about to come out from within me into the world. Like the mothers I interviewed, I feel that I will in some way be different when that happens. I am proud that I have done this myself, within my own practice, using my own resources, and without the support (and restriction) of an organisation and look forward to future developments.

76,596 words

BIBLIOGRAPHY

Family Business on the Couch.

(1984). Longman Dictionary of the English Language, Longman.

(2007). "Stepfamilies." Focus on Families Retrieved 10th December, 2008, from <http://www.statistics.gov.uk/>.

(2008, 11th April 2008). "Oxford English Dictionary Online." Retrieved 2nd March, 2008, from <http://dictionary.oed.com>.

Allan, G., S. Hawker, et al. (2008). Kinship in Stepfamilies. The International Handbook of Stepfamilies Policy and Practice in Legal, Research, and Clinical Environments. J. Pryor. New Jersey, Canada, John Wiley & Sons. **15**: 85-98.

Allan, G., S. Hawker, et al. (2004). Britain's Changing Families. Handbook of Contemporary Families: Considering the Past, Contemplating the Future. M. Coleman and L. H. Ganong. Thousand Oaks, California, Sage Publications.

Alvesson, M. and K. Sköldbberg (2000). Reflexive Methodology, New Vistas for Qualitative Research. Los Angeles, London, New Delhi, Singapore, Sage Publications.

Asherson Bartram, C. (2006). Learning Agreement. London, Middlesex University: 36.

Baham, M. E., A. A. Weimer, et al. (2008). Sibling Relationships in Blended Families. The International Handbook of Stepfamilies Policy and Practice in Legal, Research, and Clinical Environments. J. Pryor. New Jersey, Canada, John Wiley & Sons. **15**: 85-98.

Barber, P. (2002). "Gestalt - a Prime Medium for Holistic Research and Whole Person Education." British Gestalt Journal **11**(2): 78-90.

Barber, P. (2006). Becoming a Practitioner Researcher A Gestalt Approach to Holistic Inquiry. London, Middlesex University Press.

Batchelor, J., B. Dimmock, et al. (1994). Understanding stepfamilies: what can be learned from callers to the STEPFAMILY telephone counselling service. London, Stepfamily.

Behar, R. L. (1996). The Vulnerable Observer. Anthropology that Breaks your Heart. Boston, Beacon Press.

Belenky, M. F., B. M. Clinchy, et al. (1986). Women's Ways of Knowing, The Development of Self, Voice and Mind, Basic Books.

- Belenky, M. F., B. M. Clinchy, et al. (1997). Women's Ways of Knowing, The Development of Self, Voice and Mind, Basic Books.
- Bell, V. (2001). "The Phone, the Father and Other Becomings: On HHouseholds (and Theories) that no longer hold." Cultural Values 5(3).
- Bettelheim, B. (1976). The Uses of Enchantment, the meaning and importance of fairy tales. London, Penguin Books.
- Bion, W. R. (1961). Experiences in Groups and Other Papers, Routledge.
- Birch, M. and T. Miller (2000). "Inviting Intimacy: The interview as a therapeutic opportunity." International Journal of Research Methodology 3(3): 189-202.
- Boal, A. (1995). The Rainbow of Desire, the Boal Method of Theatre and Therapy, Routledge.
- Bond, T. (2005). A missing ethic? The intricate ethical challenges posed by psychological intimacy and reciprocity in psychotherapy, British Association of Counselling.
- Bray, J. H. (1988). Children's development during early remarriage. Impact of Divorce, Single parenting and Stepparenting on Children. E. M. Hetherington and J. D. Aratesh. Hillsdale, NJ, Lawrence Erlbaum Associates.
- Bray, J. H. and S. H. Berger (1993). "Developmental issues in stepfamilies research project: Family relationships and parent-child interactions." Journal of Family Psychology 7: 76-90.
- Buber, M. (1958). I and Thou. Edinburgh, T & T Clarik.
- Carter, A., Ed. (1991). The Virago Book of Fairy Tales. London, Virago Press Limited.
- Cartwright, C. (2005). "Stepfamily Living and Parent-Child Relationships: An Exploratory Investigation." Journal of Family Studies 11, No 2.
- Cartwright, C. (2008). Resident Parent-Child Relationships in Stepfamilies. The International Handbook of Stepfamilies Policy and Practice in Legal, Research, and Clinical Environments. J. Pryor. New Jersey, Canada, John Wiley & Sons.
- Cartwright, C. and F. Seymour (2002). "Young Adults' Perceptions of Parents' Responses in Stepfamilies." Journal of Divorce and Remarriage 37(3/4): 123-142.
- Cartwright, D. and A. Zander, Eds. (1953). Group Dynamics, Research and Theory. New York, Evanston and London, Harper & Row.
- Casement, P. (1985). On Learning from the Patient. London, Routledge.

- Chase, S. E. (2005). Narrative Inquiry. Handbook of Qualitative Research. N. K. Denzin and Y. S. Lincoln. Thousand Oaks, London, New Delhi, Sag Publications.
- Church, E. (1999). "Who are the people in you family? Stepmothers' diverse notions of kinship." Journal of Divorce and Remarriage **31**(1/2): 83-105.
- Clinchy, B. (1996). Connected and Seperate Knowing -Towards a Marriage of Two Minds. Knowledge, Difference and Power. N. Goldberger, J. Tarule, B. Clinchy and M. Belenky. New York, Basic Books.
- Cohen, L. (1992). Anthem. The Future, Columbia.
- Coleman, M., L. Ganong, et al. (2000). "Reinvestigating Remarriage: Another Decade of Prgress." Journal of Marriage and the Family **62**(4): 1288-1307.
- Coleman, M., J. Troilo, et al. (2008). The Diversity of Stepmothers: The Influences of Stigma, Gender, and Context on Stepmother Identities. The International Handbook of Stepfamilies Policy and Practice in Legal, Research, and Clinical Environments. J. Pryor. New Jersey, Canada, John Wiley & Sons. **15**: 85-98.
- Cresswell, J. W. (1998). Qualitative Inquiry and Research Design, Sage Publications.
- Daly, M. and M. Wilson (1996). Evolutionary Psychology and Marital Conflict: The Relevance of Stepchildren. Sex, power, conflict: feminist and evolutionary perspectives. M. B. N. Malamuth. New York, Oxford University Press: 9-28.
- Daly, M. and M. Wilson (1998). The Truth about Cinderella; A Darwinian View of Parental Love. London, Winfield and Nicholson.
- De'Ath, E. and D. Slater, Eds. (1992). Parenting Threads Caring for Children when Couples Part, Stepfamily Publications The National Stepfamily Association.
- Debold, E., D. Tolman, et al. (1996). Embodying Knowledge, Knowing Desire: Authroity and Split Subjectivities in Girls' Epistemological Development. Knowledge, Difference and Power Essays Inspired by Women's Ways of Knowing, Basic Books.
- Denzin, N. K. and Y. S. Lincoln, Eds. (2003). The Qualitative Researcher as Bricoleur and Quilt Maker. The Landscape of Qualitative Research, Sage Publications.
- Denzin, N. K. and Y. S. Lincoln (2005). The Discipline and Practice of Qualitative Research. the Sage Handbook of Qualitative Research. N. K. Denzin and Y. S. Lincoln. Thousand Oaks, Sage Publications.

Douglas, B. and C. Moustakas (1984). Investigative Social Research: Individual and Team Field Research. Beverley Hills, Sage.

Elbow, P. (1973). Writing Without Teachers. New York, Oxford University Press.

Etherington, K. (2000). Narrative Approaches to Working with Adult Male Survivors of Child Sexual Abuse. London and Philadelphia, Jessica Kingsley Publishers.

Etherington, K. (2004). Becoming a Reflexive Researcher Using ourselves in research. London and Philadelphia, Jessica Kingsley.

Etherington, K. (2004). Connecting Doctoral Research Topics to Ourselves. Becoming a Reflexive Researcher Using Our Selves in Research. London and Philadelphia, Jessica Kingsley: 29-30.

Feder, B., Ed. (2006). Gestalt Group Therapy, Gestalt Institute Press.

Feder, B. and R. Ronall, Eds. (1980). Beyond the Hot Seat. New York, Gestalt Journal Press.

Ferri, E. (2004). The fourth age
Thirty-something; time to settle down? Seven Ages of Man and Woman A look at life in Britain in the Second Elizabethan Era. I. Steward and R. Vaitilingam, Economic & Social Research Council: 22.

Fido, M., R. Gibbins, et al. (2006). General Household Survey 2005. O. f. N. Studies.

Fontana, A. and J. H. Frey (2000). The Interview, From Structured Interview to Negotiated Text. The Sage Handbook of Qualitative Research. Y. S. L. Norman K. Denzin. Thousand Oaks, Sage Publications.

Freud, S. (1911). "The Interpretation of Dreams (3rd Edition)." 3rd. Retrieved 1th February, 2009, from <http://www.psywww.com/books/interp/toc.htm>.

Friedman, H. and S. Karakauer (1992). "Learning to Draw and Interpret Standard and Time-Line Genograms: An Experimental Comparison." Journal of Family Psychology 6(1): 77-83.

Ganong, L. H. and M. Coleman (2004). Stepfamily Relationships: Development, dynamics and interventions. New York, Kluwer Academic/Plenum Press.

Glaser, B. G. and A. L. Strauss (1967). "The discovery of Grounded Theory."

Goldberger, N. R., J. M. Tarule, et al. (1996). Knowledge, Difference and Power Essays Inspired by Women's Ways of Knowing, Basic Books.

- Gomez, I. (1997). *An Introduction to Object Relations*. London, Free Association Books.
- Gorell Barnes, G. (1998). *Family Therapy in Changing Times*, Palgrave Macmillan.
- Gorell Barnes, G. (1998). Step-families. *Family Therapy in Changing Times*, Palgrave Macmillan: 129.
- Gorell Barnes, G., Thompson, et al. (1998). *Growing up in Stepfamilies*. Oxford, Clarendon Press.
- Hayes, S. (1996). "The Cultural Contradictions of Motherhood."
- Hayman, S. (1999). *Step-families: living successfully with other people's children*, London: Vermilion, 1993 (2001 [printing]).
- Heron, J. (1988). Validity in Cooperative Inquiry. *Human Inquiry in Action*. P. Reason. London
Thousand Oaks
New Delhi, Sage Publications: 185.
- Heron, J. and P. Reason (2001). The Practice of Cooperative Inquiry Research 'with' rather than 'on' People. *Handbook of Action Research Participative Inquiry and Practice*. P. Reason and H. Bradbury. London
Thousand Oaks
New Delhi, Sage Publications: 185.
- Hetherington, E. M. and K. M. Jodl (1994). Stepfamilies as settings for child development. *Stepfamilies: Who benefits? WHO does not?* A. Booth and J. Dunn. Hillsdale, NJ, Lawrence Erlbaum Associates.
- Hetherington, M. E. (2003). "Social Support and the Adjustment of Children in Divorced and Remarried Families." *Childhood* **10** (2): 217-236.
- Hollway, W. (1997). Mothers, Parenting, Gender Development and Therapy. *Mothers and Ambivalence*. W. H. a. B. Featherstone. London & New York, Routledge.
- Houston, G. (1993). *Being and Belonging, Group, Intergroup and Gestalt*. Chichester, John Wiley and Sons.
- Ihinger-Tallman, M. and K. Pasley (1987). *Remarriage*. Beverley Hills and London, Sage.
- Jacobs, J. (1979). *English Fairy Tales*. London, Frederick Muller Limited.
- Josselson, R. (1996). On Writing Other People's Lives; Self-Analytic Reflections in Narrative Research. *Ethics and Process in the Narrative Study of Lives*. R. Josselson. London, Sage.

Koerner, S. S., L. A. Rankin, et al. (2004). "Mother Re-Partnering After Divorce: Diverging Perceptions of Mothers and Adolescents." Journal of Divorce and Remarriage **41**(1/2): 25-38.

Kohler Riessman, C. (1993). Narrative Analysis. Newbury Park, London, New Delhi, Sage Publications.

Kohler Riessman, C. (2008). Narrative Methods for the Human Sciences. California, Sage Publications.

Lang, A. (1965). Fifty Favourite Fairy Tales Chosen from the Colour Fairy Books of Andrew Lang by Kathleen Lines. London, Nonesuch Press.

Lather, P. (1993). "Fertile Obsession; validity after post structuralism." The Sociological Quarterly **34**(4): 673-693.

Lawler, S. (2000). Mothering the Self mothers, daughters, subjects. London, Routledge.

Levin, I. (1997). "The Stepparent Role from a Gender Perspective." Marriage and Family Review **26**(1-2): 123-133.

Mason, M. A. (2000). Was Cinderella Right? The new social Darwinism targets stepparents. Handbook of Contemporary Families, considering the past contemplating the future. Marilyn Coleman and L. ganong. Thousand Oaks, CA, Sage.

Maxwell, J. A. (1992). "Understanding and Validity in Qualitative Research." Harvard Educational Review(62): 279-300.

McEvedy, F. (2005). The step-parents' parachute. London, Time Warner.

McNeill, P. (1990). Research Methods. New York, Routledge.

Mignot, J.-F. (2008). Stepfamilies in France Since the 1990s: An Interdisciplinary Overview. The International Handbook of Stepfamilies Policy and Practice in Legal, Research, and Clinical Environments. J. Pryor. New Jersey, Canada, John Wiley & Sons.

Morse, J. (2000). "Editorial: Writing my own Experience." Qualitative Health Research **12**(9): 1159 - 1160.

Moustakas, C. (1981). Heuristic Research. Human Inquiry: A source book of New Paradigm Research. J. R. Peter Reason. Chichester, New York, J. Wiley.

Moustakas, C. R. (1994). Phenomenological Research Methods, Sage Publications.

Murphy, M. and D. Wang (1999). Forecasting British Families into the Twenty-first Century. Changing Britain: Families and Households in the 1990's. S. McRae. New York, Oxford University Press.

Nielsen, L. (1999). "Stepmothers: Why so much stress? A review of the research." Journal of Divorce and Remarriage **30**(1-2): 115-118.

Papernow, P. L. (1993). Becoming a Stepfamily Patterns of Development in Remarried Families. Cleveland, Gestalt Institute of Cleveland.

Perls, F. (1973). The Gestalt Approach and Eye Witness to Therapy. Palo Alto CA, Science and Behavior Books.

Perls, F., R. Hefferline, et al. (1951). Gestalt Therapy Excitement and growth in the Human Personality. London, Souvenir Press.

Perls, F., R. Hefferline, et al. (1951). The Starting Situation. Gestalt Therapy Excitement and Growth in the Human Personality. London, Souvenir Press Ltd: 247.

Perls, F., R. Hefferline, et al. (1951). The Structure of Growth. Gestalt Therapy Excitement and growth in the Human Personality. London, Souvenir Press: 247.

Perls, F., R. Hefferline, et al. (1951). Technique of Awareness. Gestalt Therapy Excitement and growth in the Human Personality. London, Souvenir Press: 247.

Perls, L. and E. Rosenfeld (1982). A Conversation with Laura Perls. An Oral History of Gestalt therapy. J. Wysong and E. Rosenfeld. Highland, New York, The Gestalt Journal.

Phillipson, P. (2001). Self in Relation. New York, The Gestalt Journal Press.

Pryor, J. (2008). Children's Relationships with Nonresident Parents. The International Handbook of Stepfamilies Policy and Practice in Legal, Research, and Clinical Environments. J. Pryor. New Jersey, Canada, John Wiley & Sons. **15**: 85-98.

Pryor, J. (2008). Children in Stepfamilies: Relationships with Nonresident Parents. The International Handbook of Stepfamilies Policy and Practice in Legal, Research, and Clinical Environments. J. Pryor. New Jersey, Canada, John Wiley & Sons.

Pryor, J., Ed. (2008). The International Handbook of Stepfamilies Policy and Practice in Legal, Research, and Clinical Environments. New Jersey, Canada, John Wiley & Sons.

Pryor, J. (2008). Where to from Here? Stepfamilies and the Future. The International Handbook of Stepfamilies

Policy and Practice in Legal, Research, and Clinical Environments. J. Pryor. New Jersey, Canada, John Wiley & Sons.

Reason, P. (1988). The Co-operative Inquiry Group. Human Inquiry in Action: Developments in New Paradigm Research. P. Reason, Sage Publications.

Reason, P. (1988). The Cooperative Inquiry Group. Human Inquiry in Action: Developments in New Paradigm Research, Sage Publications.

Reason, P., Ed. (1988). Human Inquiry in Action: Developments in New Paradigm Research, Sage Publications.

Reason, P. and H. Bradbury, Eds. (2004). A Handbook of Action Research. London, Thousand Oaks, New Delhi, Sage Publications.

Reber, A. S. (1988). The Penguin Dictionary fo Psychology. London, Penguin Books.

Richardson, E. (2003). Birth of the Ethical Attitude in a Clinical Setting. The Ethical Attitude in Analytic Practice. H. M. Solomon and M. Twyman. London, Free Association Books.

Robertson, J. (2008). Stepfathers in Families. The International Handbook of Stepfamilies
Policy and Practice in Legal, Research, and Clinical Environments. J. Pryor. New Jersey, Canada, John Wiley & Sons.

Robinson, E. L. E. and H. L. N. J. Nelson (1997). Fluid Families: The Role of Children in Custody Arrangements” in Feminism and Families. New York, Routledge.

Robinson, M. and D. Smith (1993). Step by step: focus on stepfamilies. New York, London: Harvester Wheatsheaf in association with Stepfamily.

Robinson, M. and D. Smith (1993). Step by Step Focus on Stepfamilies, Harvester Wheatsheaf.

Salisbury, C. (2004). Couples in Stepfamilies, Middlesex.

Salisbury, C. and C. Walters (1997). All Together Now
What to expect when Stepfamilies get together, National Stepfamily Association.

Smith, J. B. B. D. D. (1994). "Understanding Stepfamilies: What can be learned from callers to the Stepfamily Counselling Service."

Smith, M. (2008). Resident Mothers in Stepfamilies. The International Handbook of Stepfamilies
Policy and Practice in Legal, Research, and Clinical Environments. J. Pryor. New Jersey, Canada, John Wiley & Sons. **15**: 85-98.

- Smith, M. K. (2001). "Kurt Lewin: groups, experiential learning and action research." Retrieved 28th June, 2007, from www.mfed.org/thinkers/et-lewin.htm.
- Sparkes, A. C. (1996). "The Fatal Flaw: A Narrative of the Fragile Body-Self." Qualitative Inquiry 2(4): 463-494.
- Sparkes, A. C. (2002). Telling Tales in Sport and Physical Activity, Human Kinetics.
- Sparkes, A. C. (2007). "Embodiment, academics and the autistic culture; a story seeking consideration." Qualitative Research 7(4): 521-550.
- Stern, D. N. (1998). The Motherhood Constellation - A Unified View of Parent-Infant Psychotherapy. London, Karnac Books.
- Stewart, S. D. (2007). Brave New Stepfamilies; Diverse Paths Toward Stepfamily Living. Thousand Oaks, London, New Delhi, Sage Publications.
- Strauss, A. and J. Corbin (1998). Basics of Qualitative Research Techniques and Procedures for Developing Grounded Theory, Sage Publications.
- Wellington, J., A.-M. Bathmaker, et al. (2005). Succeeding with your Doctorate. London, Sage.
- Wilson, L. (1996). Diary of a Stepfather. London, Stepfamily Publications.
- Winnicott, D. W. (1960). The Relationship of a Mother to her Baby at the Beginning. The Child, the Family and the Outside World. London, Penguin Psychology.
- Winnicott, D. W. (1964). The Child, the Family and the Outside World. London, Penguin.
- Winnicott, D. W. (1965). The Family and Individual Development. London, Tavistock/Routledge.
- Winnicott, D. W. (1986). Home is Where we Start From. London, Penguin Books.
- Wymore, J. (2006). Gestalt Therapy and Human Nature; Evolutionary Psychology Applied. Bloomington, Indiana, AuthorHouse.
- Yalom, I. D. (1995). The Theory and Practice of Group Psychotherapy. New York, Basic Books.
- Yontef, G. (1988). Gestalt Therapy. Awareness, Dialogue and Process Essays on Gestalt Therapy. New York, The Gestalt Journal Press Inc.
- Zinker, J. (1978). Creative Process in Gestalt Therapy. New York, Vintage Books.

APPENDICES - CONTENTS

APPENDIX I – PARTICIPANTS

Introducing the Participants	245
Biograms	248
Monologues	256
Amanda	256
Barbara	275
Elaine	292
Esther	312
Leanne	327
Mary	341
Robin	346
Sally	358
Extracts from Analysed Transcripts	392
Clody	392
Mary	399

APPENDIX II – PROJECT DESIGN AND DOCUMENTS

Original Design from Learning Agreement	405
Extract from Transcript of Focus Group	407
Documents Relating to Research	242
Recruiting Participants	421
Pre-Interview Meeting	422
Interview Release Form	422
Approval of Transcript	424

APPENDIX III – INFLUENTIAL BOOKS, SEMINARS AND PEOPLE

Women’s Ways of Knowing – Separate and Connected Knowing	425
--	-----

Gestalt and Evolutionary Theory	429
Specialist Seminars and CARPP Conference	435
Seminars Attended	435
Jane Speedy	436
Kim Etherington	437
Tim Bond	438
Miller Mair	439
Isha McKenzie Mavinga	440
Jean Knox	442
Emmy Van Deurzen	443
Andrew Sparkes	443
Emerging Approaches to Inquiry 11	443
Flyer	449
The Impact of the Observer on the Observed	451

APPENDIX IV – PRODUCTS ARISING FROM PROJECT

i) Workshops and Groups	453
List of Presentations	453
AAGT Amsterdam	455
AAGT Vancouver	455
StepIn ASAP i	457
EAGT Athens	458
UKAGP London	460
StepIn ASAP ii	463
AAGT Manchester	463
ii) StepIn ASAP	464
Handouts	464
Flyer	466
StepIn ASAP Research Form	468
Notes from Committee Meeting	470
iii) Book Proposal	473

Biography	464
Summary and Overall Description	474
Rationale	474
Chapter Outline	476

APPENDIX V – FAIRY AND FOLK TALES

i) Stepmother Stories	479
ii) A Stepfather Tale	481
iii) Mother Stories	482
iv) Fairy Tale Bibliography	482

APPENDIX I – PARTICIPANTS

Introducing the Participants

Myself

I have been married twice and live with my second husband. I have two children from my first marriage and my husband has one child from his. All the children have left home.

Amanda

Amanda married when she was nineteen and had two children. When the oldest was about five she left her husband who entered a new relationship with Julie, so her children had a stepmother. Amanda herself remained single but her children lived for a period of time with their father and stepmother. She talked about the influence of the stepmother on her and her daughter's relationship.

Barbara (see Robin)

Barbara is Andy's current partner – Robin's ex husband. She had two children in her first marriage to an alcoholic man. After she left him she lived as a single parent but in a relationship with Andy. He didn't live with her while the children were growing up but does now that they have left home.

Bella

Bella grew up in another country and has a daughter from her first marriage and two children with her second partner who she didn't marry. She left her second husband and lived for several years as a single parent in an on/off relationship with Vince. She is now settled with Dan – all her children have left home.

Clody

Clody had two children from her first marriage. After they separated she entered a new relationship with Mike who had three children. They lived together with four of the children and had a further child between them. Their relationship has ended and Clody now lives on her own and has remained in touch with all but one of her stepchildren, but not their father

Elaine

Elaine is opposed to marriage. She lives with her partner John who has two grown up children from a previous marriage. They have a son between them who still lives at home.

Esther

Esther's first husband had two children. She had a child with him, when he was ten they split up acrimoniously. Since then she has been in two relationships each with men who have children. She talked about her relationships with her stepchildren and with her son who has now left home.

Leanne

Leanne has two sons from her first marriage. Her husband left when the youngest was one and she met a man who also had two sons. When they got older the sons lived in a house next door to them. The mother of one of her partner's sons is involved in special occasions such as Christmas and birthdays. The spirit of her family seemed very communal. The children are all grown up and one of them lives next door with his partner and child.

Mary

Mary was pregnant with her first child Grace when she got together with her partner who she still lives with. He brought up Grace as his own. Grace has now left home. Mary talked about her concerns in regard to Grace's relationship with her biological father.

Robin

Robin's first marriage was to Andy who had two children from a previous relationship. They had two further children. She and Andy separated and he entered a new relationship with a friend Barbara who I also interviewed. Robin is in a relationship with a man who has no children. The children no longer live at home. The entire family are friendly and meet for occasions such as Christmas and birthdays.

Sally

Sally's first husband left her with two young children. She then met Robert and had three more children. She lived some of the time abroad and found arrangements with her first husband disruptive. Eventually he was discovered to have sexually abused her daughter which she partly attributes to her not being there as a modifying influence.

Biograms

The following Biograms show the biological structures within participant's stepfamilies. The Biograms are followed by descriptions of who is in each family, firstly in participant words. In each case I depict the participants' first family and their progression to their family at the time of interview. It can be seen that the 'ghost' of the original family remains in the structure of subsequent families. I have used colour to show the original families within the new structures.

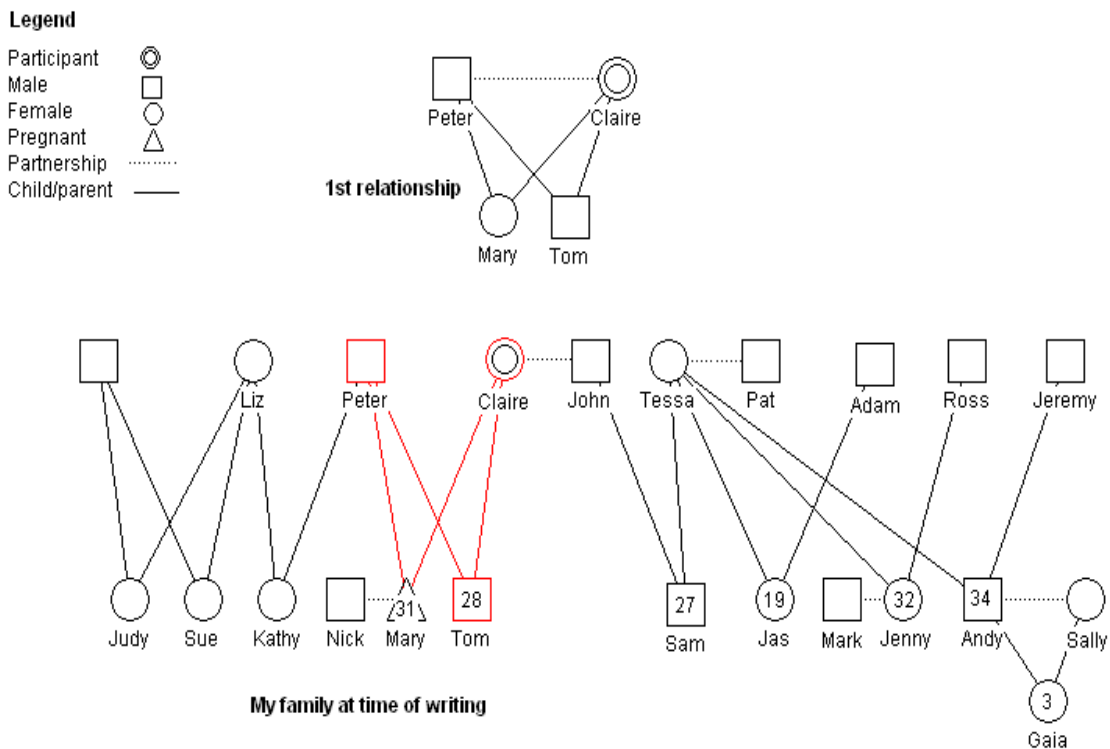

Figure 14 - My family's Biogram

My Own Family

My family consists of me and my two children Sarah and Daniel. They are both Dave's who was my first husband. I left him after nine years He now has a daughter with Liz who had two daughters from a previous relationship. My second and current partner Andrew has a son Sam with Mary. Sam is one of four each with a different father.

When Sam was thirteen he came to live with us. His oldest brother is now married and he and Sally have a young child. If you count the children and adults connected through the stepfamily, there are ten of each”.

Amanda

If I think of my family, I think of my children and me, and Fred their father who I’m separated from. Then there’s Julie who he was married to and is now dead and now a new woman called Mary. It looks as if she’s going to be a fixture.

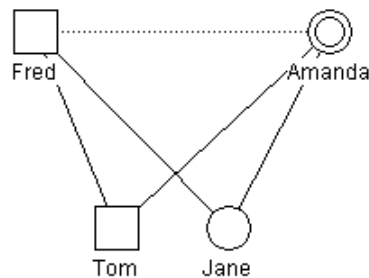

Original relationship

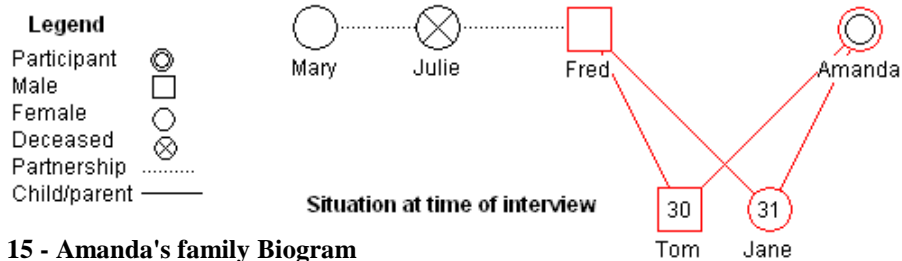

Figure 15 - Amanda's family Biogram

Barbara

I’ve got two children, a boy and a girl and they’ve both got the same father. We’ve been separated for a long time and he’s now dead. My current partner has four children from two different marriages; two boys from the first and two girls from the second. The two eldest are both married, the eldest one’s got one son and the other one’s got a son and a daughter.

Robin

My first husband was Andy. I married him in 1981 and got two daughters Amber and Erica. He was married before he was married to me, to Rose with whom he had two sons, David and Richard. They've both got children, so Richard is married to Jane and they've got a son and David is married to Sophia and they've got two children Mary and Tom. Then I married Steven and we don't have children and he has no biological children

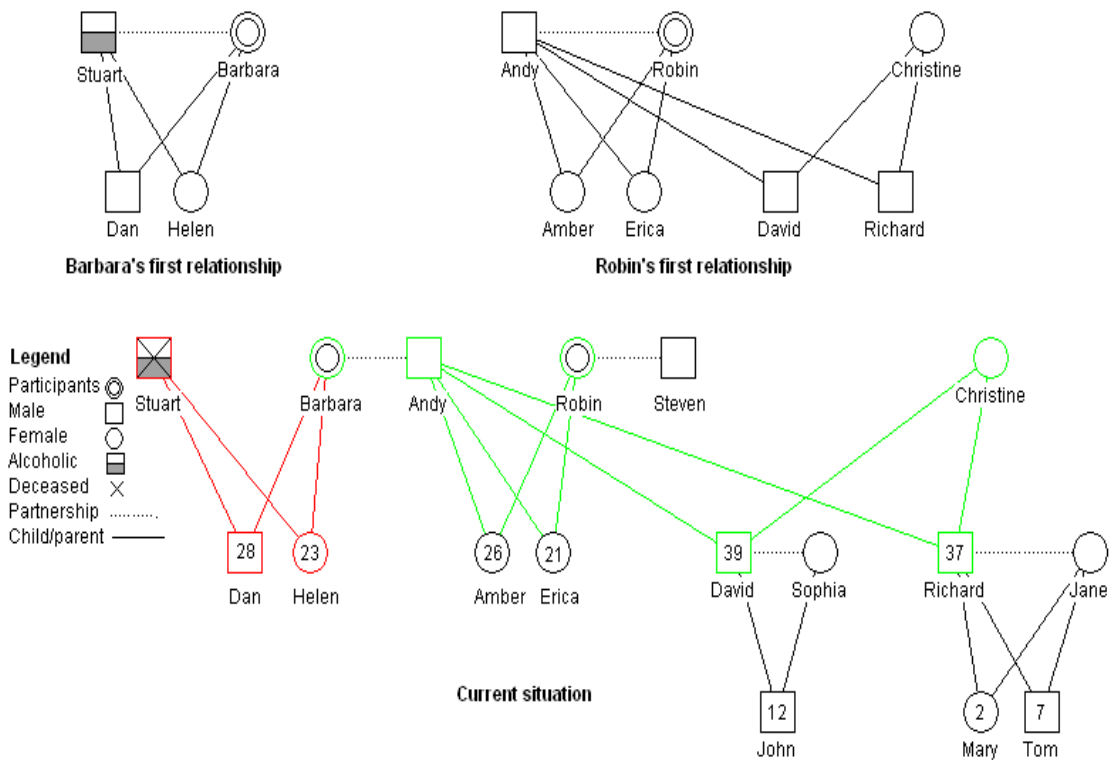
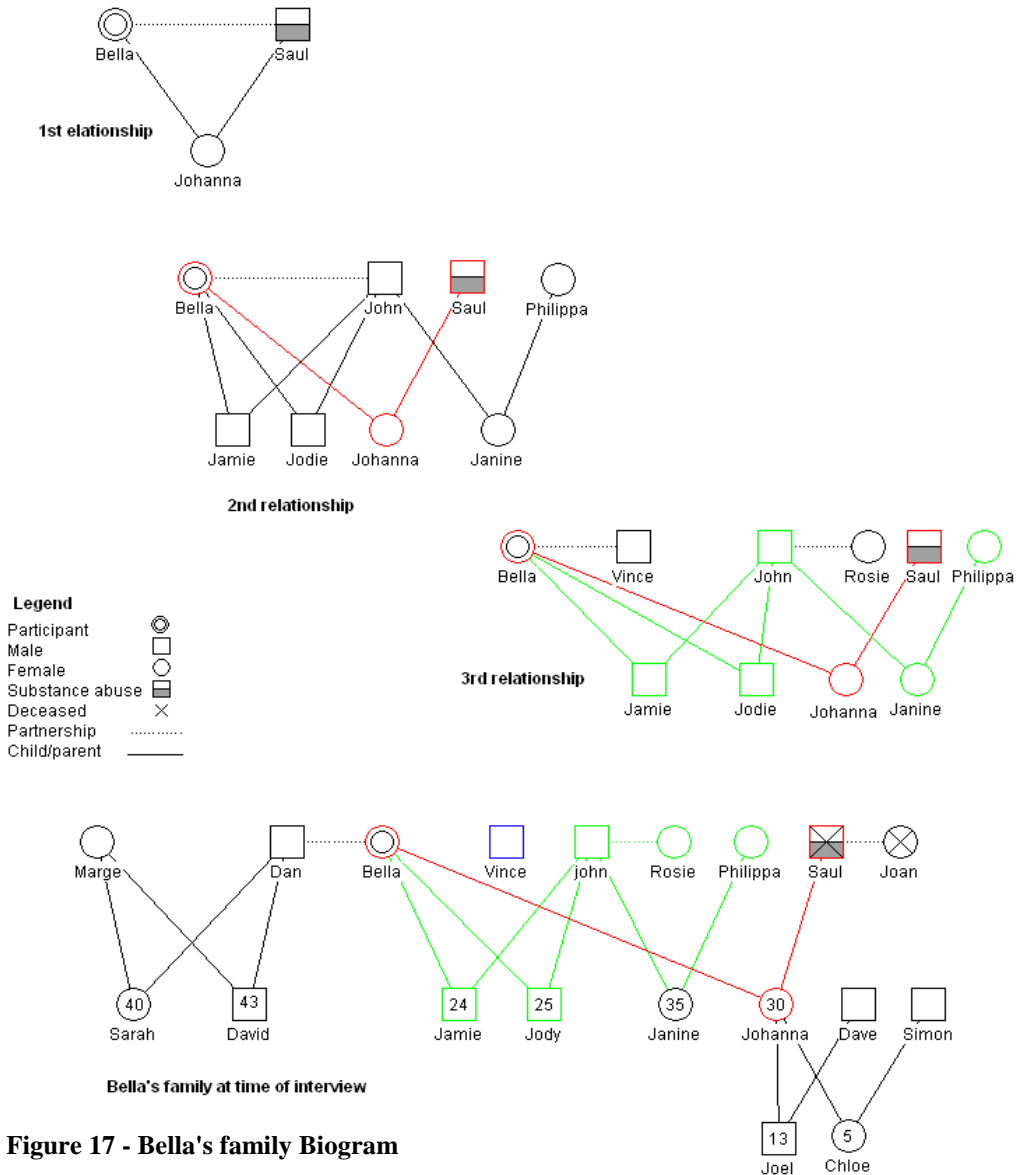

Figure 16 - Robin and Barbara's family Biogram - an extended stepfamily group

Bella

In my family there's me and Dan and then my oldest daughter Johanna from my first marriage; She's the one that was brought up with a stepfather John who is the father of Jody and Jamie my two boys. John had a child already from his first marriage.

Then I have Jody and Jamie with John. Dan also has two children a boy and a girl. Johanna's on her own now but she's got two kids.



Clody

I was married to Brian and I had two boys, Andy and Luke. Then I divorced and met Steven who had custody of his three children Sue, Ian and Sean; there's about two years between each of those, I can't be more precise, and between me and Steve we had Julia. Steve and I are now separated.

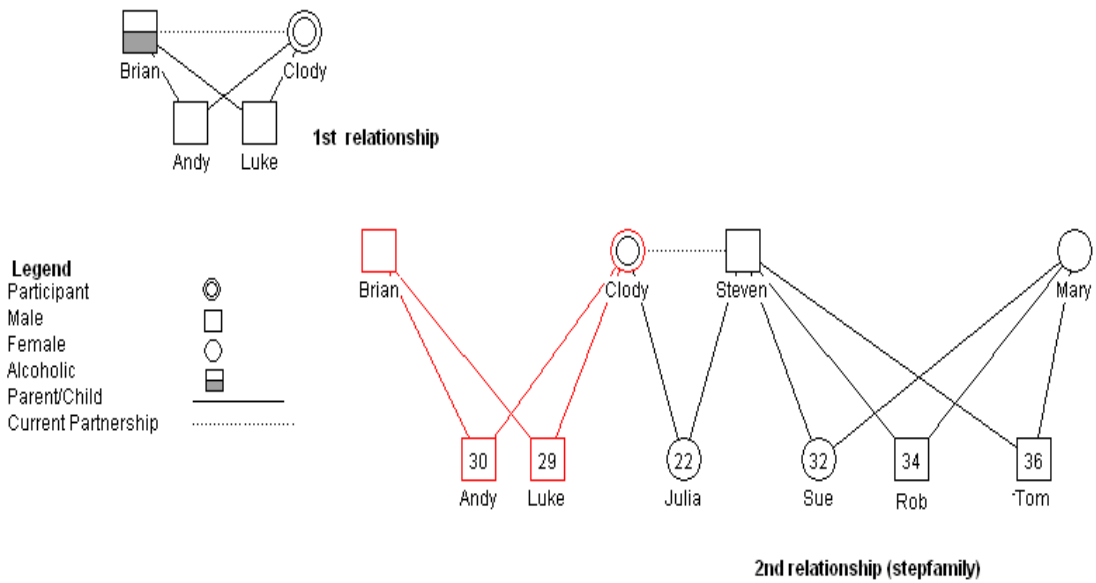

Figure 18 - Clody's family Biogram

Elaine

I have two stepsons and they are the sons of my current partner. Gabriel has two little girls, Gaia and Alicia and they're both in long term relationships. Marsha is planning to marry his girlfriend next year and Gabriel lives with Naomi who is the mother of Gaia and Alicia. Then I live with John who's their Dad and we have a son called Michael.

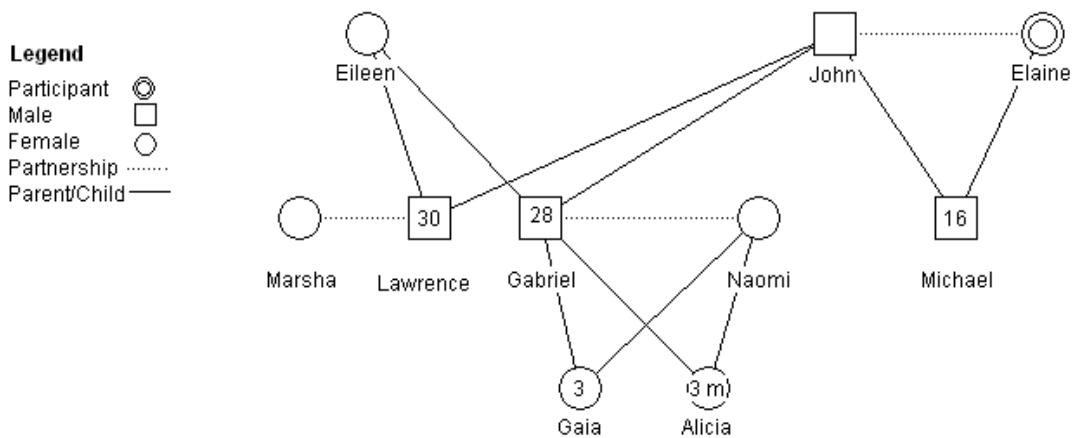

Figure 19 - Elaine's family Biogram

Esther

I've got one son Peter and his dad is Gary who already had two boys Mark and Daniel are Gary's two boys who are the first children that I mothered. We separated and I had a relationship with Henry who had a boy and a girl George and Molly with someone else. I was very involved with them. Now I am with John and he's got two daughters. One of them Lily does officially live with us although she's at university Peter is in Australia at the moment, and of course I mustn't forget Leila who is John's youngest daughter and who lives with her mother.

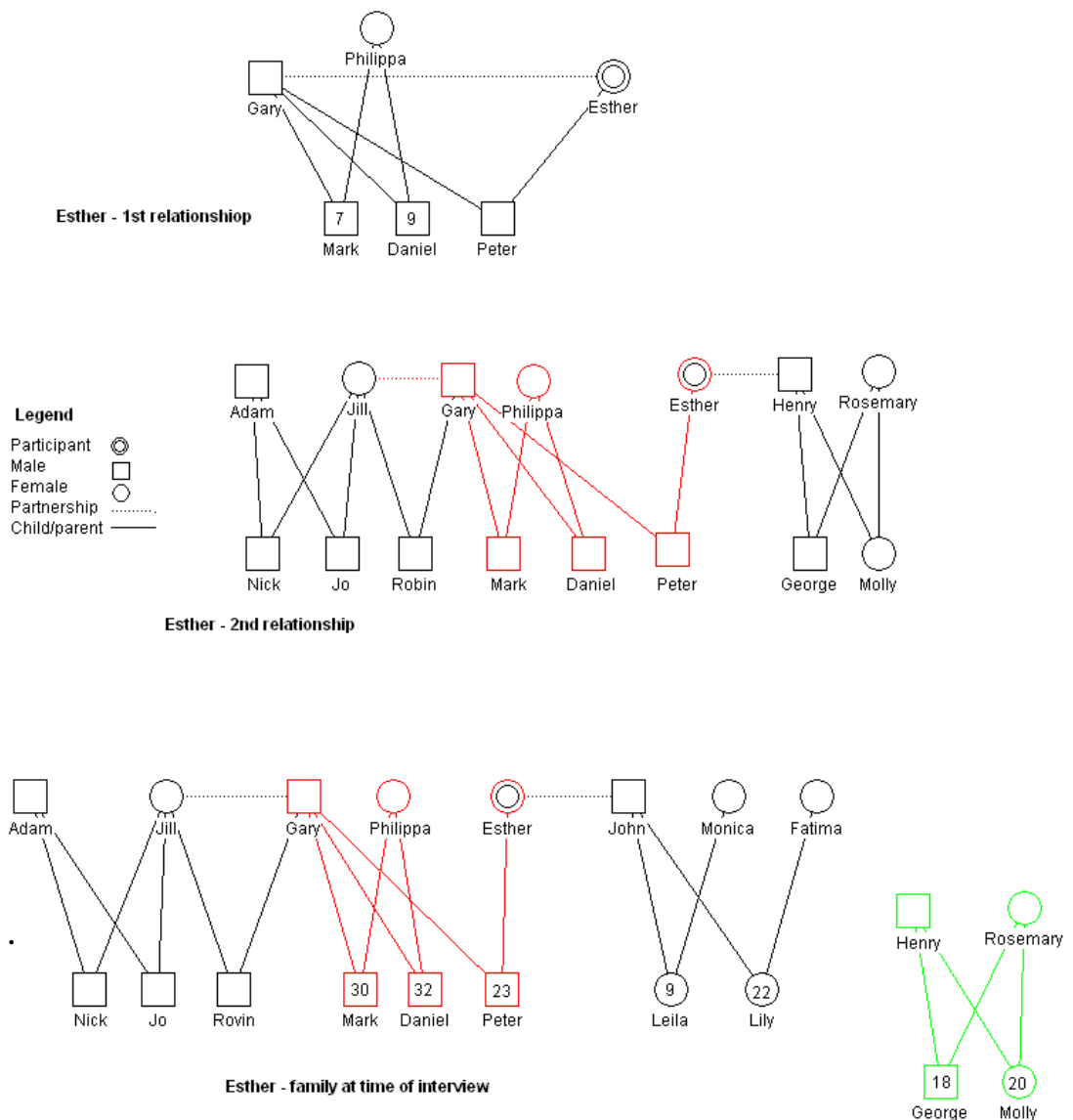

Figure 20 - Esther's family Biogram

Leanne

In my family there is me, Dan and David. John is my partner and he's got two boys with two different mothers, Dan and Jack. They're all boys and my Dan is the oldest. John and I don't have children between us. My Dan has got a partner Janet and a baby Rose. He works with me. David is as yet unattached.

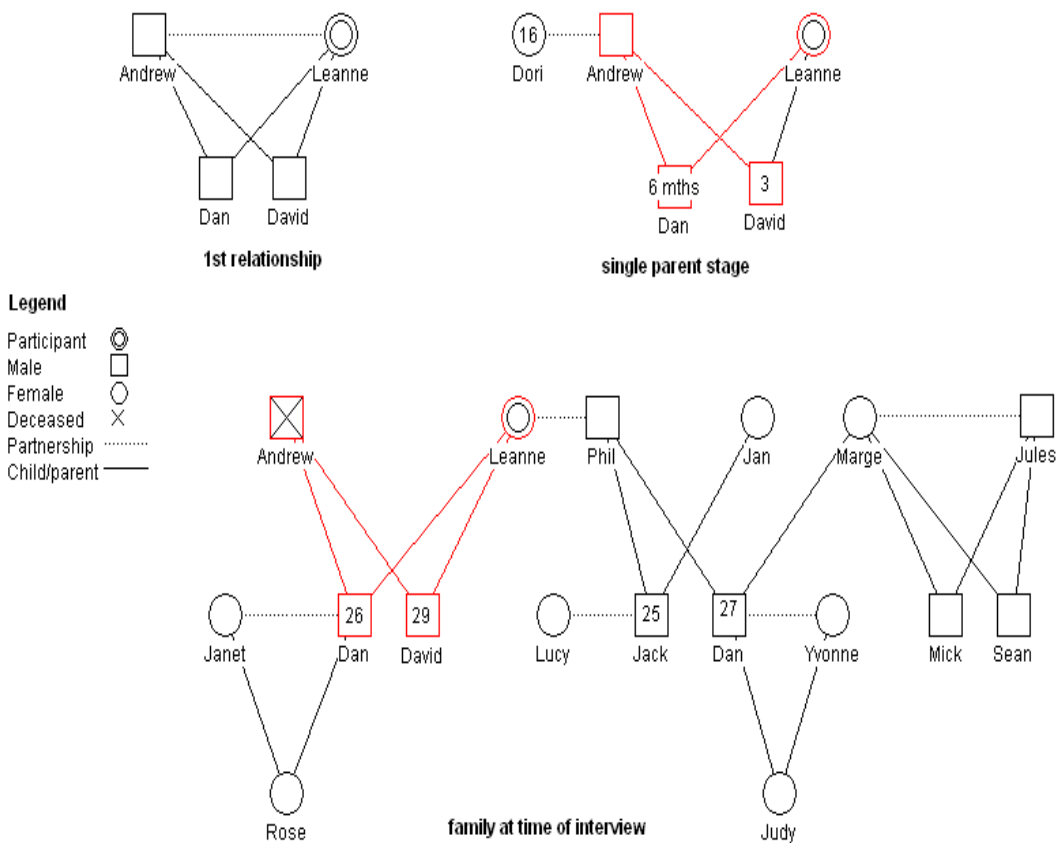

Figure 21 - Leanne's family Biogram

Mary

In my family there's me, Jim, Grace who's Howard's kid, Katie and Ruby. I was pregnant with Grace when I got together with Jim.

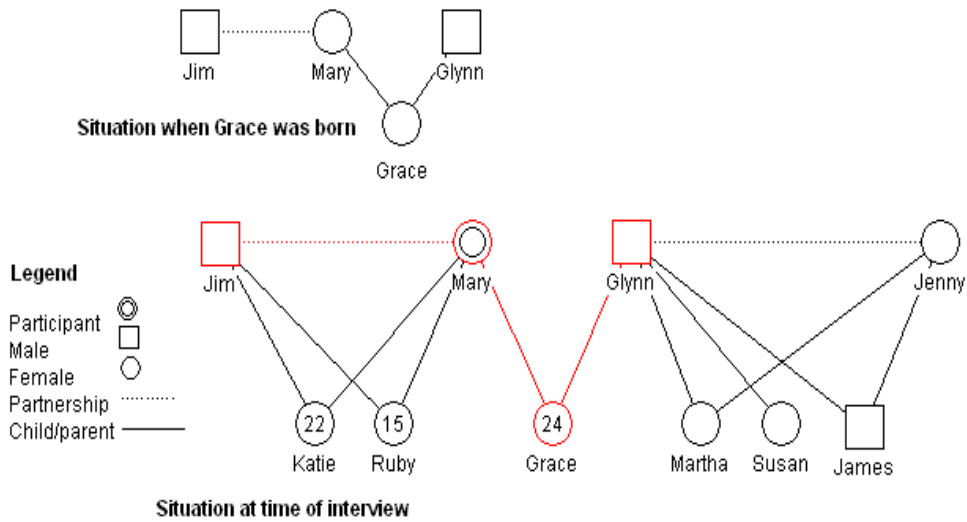

Figure 22 - Mary's family Biogram

Sally

In my family there's me and Robert my husband and the children are Olivia and Ben, who I had with Rory my first husband and Frances and Lizzie who I have with Robert. Robert and I started living together just before Lizzie was born.

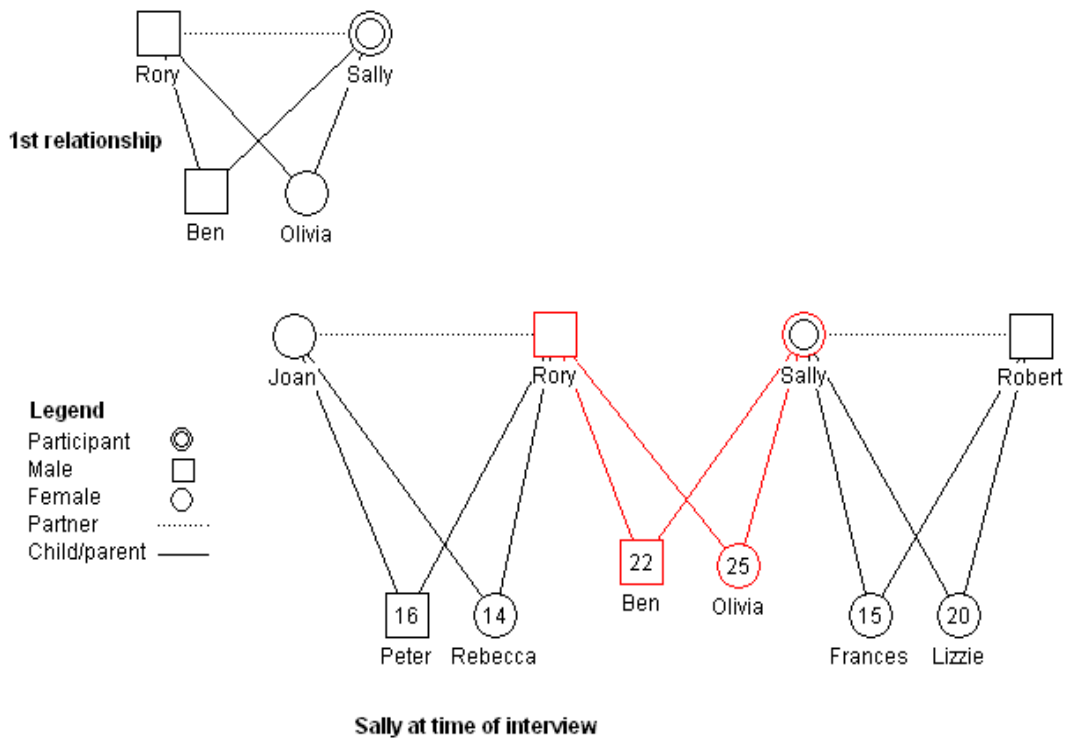

Figure 23 - Sally's family Biogram

Monologues

Amanda

If I think of my family I think of my children, me and Fred their father. Then there's Julie who he was married to and who died in '98 and there is now a new woman, who's called Carol. It looks she's Carol's going to be a fixture and she is raising questions about inheritance.

When I separated from Fred the children were five and four, I was twenty nine, had been married ten or eleven years, and had been living in this country for seven to eight years. I got together with Fred as a result of having been in love, and having some really difficult things happen with my family, another guy and my sister. Everybody ostracised me and it had the result of turning something that was innocent off.

Marriage

I met Fred when we were quite young. I was sixteen, he was eighteen and we used to camp at the same camping site. His parents were literally next to our, we had a tent and a little caravan, they had a bus which they lived in and we all spent the whole summer there. I'd been watching him picking his spots in front of the mirror and I decided that this was going to be my husband. We talked across the fence and I really wanted to go out with him, so one day my sister and I hatched up a plan and we ended up going dancing together several times, the three of us. It looked like he was more into her than me, she was his age but she didn't really fancy him, so I got him; I don't think she wanted him anyway.

Prior to this I had fallen in love with another man, really in love. It was at the same camping site and this was somebody I got to talk to when we were all sitting together celebrating one evening and I was a bit drunk. He and I had the most lovely time together wandering off and throwing ourselves around in the sand. We had one kiss and it was wonderful; it was the first kiss I really enjoyed and I just fell in love with him, I fancied him and he was really sweet.

My sister was jealous I think. She told my parents, they followed us and were very cross with me. They made me feel terrible for kissing a boy and I was treated like a whore. I had a terrible row with my father and I screamed at him “how dare you. Just because you spawned me doesn’t mean you have a right to treat me like this” and he slapped me, put me under house arrest; I wasn’t allowed to go out. It turned out that the man was engaged, which I didn’t know. So I had one glorious innocent moment that I really enjoyed, I felt the normal feelings that a young girl feels and then it had all these ghastly consequences. It was such an emotional wound that it resulted in me turning off my normal erotic feelings and converting them into something else, because I didn’t feel they were allowed.

I don’t think I’d fallen really in love with Fred, but I was determined that I was going to get somebody to marry me and I wasn’t going to get carried away by my feelings anymore. I think that Fred was safe for me; he wanted to sleep with me and I said no. He used to kiss me and I used to pick his spots. I feel terribly sad talking about this because I think I got involved with him for all the wrong reasons, but I didn’t know that. I was allowed to be with him because I didn’t really fancy him. My father didn’t approve of him but mother liked him, which I should have taken as a bad sign. But I married him anyway.

Fred and I went through all the motions. We did sleep together but I had become this sort of dead saintly body that was letting a man have sex with me. I was like this for a very long time. He was a bit of a mummy’s boy and I didn’t feel sexual feelings for him so it was safe.

Children

I was twenty five when I had Tom and twenty six when I had Jane. Both children had complications because they didn’t grow. I had to go into hospital weeks and weeks before they were born to make sure I wasn’t rushing around.

Before I had children I weighed seven and a half stone and that was my normal weight. When I was pregnant with Tom they investigated me and found that the placenta didn’t have enough nourishment in it, and that there was a danger that he might die before he was born. They said: “you have to come in, you know we’ve got

to have you in and observe you and have you lying in bed, you know you're highly strung andblah, blah, blah". I was devastated. I called Fred at lunchtime, and told him and he said "Ok I'll see you later on in hospital". I said "aren't you coming? Aren't you coming home and going to hospital with me?" he said "why?"

I burst into tears, because I wanted him there...and then I think he did come but it didn't feel loving, it didn't feel like he had any real interest. I felt that in my marriage with him there was this sort of absence. I can feel it as I'm talking to you, and feel it's still in me, this whole hurt that was in my marriage, this feeling of never really mattering, that was just awful.

Tom's birth was extremely traumatic because he was late and I had to be induced. It was my first labour so I wasn't prepared for it. It was a very quick labour, it took four hours, and I was given pethidine which I hated; it gave me hallucinations and made me feel I was going into the underworld. The midwife was nasty and caused me a lot of pain when she examined me and sent Fred out so I was abandoned to what I thought was a sadistic woman. It was just awful it was a real trauma.

I don't think Fred knew what the hell was going on. He was thrilled to be a dad but I suffered. I took one look at Tom and started bawling my eyes out, went back to bed and didn't want to see anyone. I think when I saw him it was like looking at me, the abandoned baby, and I didn't know what to do. I was supposed to stay in hospital and wait until Tom was well enough to come out and I didn't, I refused. So poor little thing, I left him in hospital on his own.

I wanted Tom to die for the first few months, I didn't really want him, but, not in any of real way, It was that I didn't want a child; I didn't think I had it in me to have a child. What I wanted was somebody to gather me up and help me recover from what felt like six or seven years torture. I remember one moment I extremely vividly, that I was driving down the hill and wanting him dead. Thinking that maybe if he was dead then all this nightmare would be over. Of course I didn't talk to anyone about this I didn't even talk to myself about it I just remember. What I now know is I had post-natal depression but Fred didn't understand it, and in fact nobody really understood it in those days.

So I had Tom, and then he got very ill, still in hospital, I was very depressed and had a sort of mini breakdown. I went home to be with my mum. In that time Fred started having affairs; up to then I don't think he did. I only went away for two or three weeks, I'd never done anything like that before and he started an affair with his secretary. I think he thought I was leaving him but I wasn't, I was just needing some care and attention.

I went back and picked up my marriage, and was still relatively unsuspecting. I got pregnant the second time and started to wake up; something in me was beginning to wake up. I became more of a woman having had one child, and going through a few things. I also found that I did have a mother instinct because of what happened when Tom was ill. I must have had a bond with Tom to know that he was in danger

I took Tom to see the doctor who was saying "there's nothing wrong, he's got a bit of a cough". I said "I'm going to take him to hospital" which I did. It turned out he had a serious chest infection, an enlarged liver, and an enlarged heart; he would have died. I visited him there and it was awful because he had hepatitis or something that affected his liver and he was kept in quarantine. I couldn't touch him, and he was crying. They didn't feed him because of his enlarged liver. They were starving him. So there he was, three months old, in this hospital on his own, crying his heart out, and it breaks my heart thinking about that. I felt really helpless but I was glad that he was being looked after, I felt that I'd saved his life.

Then I spent a lot of time just me and him. I wasn't used to being a mother and taking care. I wasn't very tactile with him, I wasn't very warm, and I did terrible things like leave him in the car, in a dark car park, leaving him or sometimes in the garden on his own when I was going shopping. When he was screaming in the mornings I would leave him screaming because I felt he needed to learn to wait for his food. I thought the longer I left him screaming the more he'd get the message. He was tiny and I wouldn't feed him. Then I was too tired. Fred was quite a sweet dad in some ways but he wasn't going to get up for them. I don't even know whether I would have allowed him; my mother came to visit once and she wanted to

and I was cross with her. I can't believe I'm telling you but it's the truth. That's what I did with both my babies.

Now I know that their early experiences are their foundation and that unless they one day remember and feel it, it'll always be there. It's always staring me in the face. I feel it more with Jane than with Tom because Tom's done a lot to deal with things. I think he really has healed something. He went through a decade of having lots of friends and drinking with them, but now I feel the damage is healed because of how we are together. He let's me give to him in ways that I tell me that that early episode is no longer active, whereas with Jane I feel it's very active still. Also the issues with her were somewhat different you know.

The thing with Jane is complicated. In some ways I was a better mother with her, but she has lots of other experiences that are not so straightforward. The whole development with Jane is very complicated. Even the fact how she was born is complicated. I had the same thing as with Tom, I had to go into hospital and Fred was having affairs at that time. I kept on dreaming about him having affairs and he was denying it. Then one night he wasn't coming home, he said he was on business. I was trying to get hold of him and I couldn't and I suddenly thought, he's having an affair with my neighbour's daughter. My whole physiology started exploding; a fright response. When they checked me out in the hospital I had foetal distress so they started monitoring me and said "we'll have to induce you if this goes on"

I tried to get hold of Fred all evening, and eventually I said to the night nurse, "wake me up if he calls". He called in the middle of the night just to say he was alright and the next morning I was induced because the measurements weren't going down. This is how Jane was born, in the middle of me thinking he was having an affair; which he was; he was sleeping with somebody that night. (he didn't tell me this for another five years).

Jane was healthier than Tom she didn't have a heart murmur or anything like this. She was also very tiny but she had a slightly better constitution because I wasn't smoking. In some ways the feeling of having her, carrying her, was very different than the feeling of carrying Tom.

After Jane's birth I lived in this marriage with Fred who now had a very, very busy business life, was hardly ever home and was always travelling. He was lying to me, so we had no real closeness and we hardly slept together. I was at home with two children in a country where I had no family and was a very frustrated, unhappy mother. Fred was away a lot, with business and having affairs and I was bored out of my head. I tried to make friends with other women with children but they weren't really women I would have normally made friends with.

Marriage Breakdown and Divorce

When Jane was a year and a half we moved into this town house with a big communal garden at the back. So there was a sense of community, there were lots of kids and we all got to know each other, the kids would come in and play and we'd do plasticine together. It was a very different life and I was growing into being a mother, enjoying being the children, playing with them, being with the neighbours and having much more of a sense of reality and connection with people. This new life didn't include Fred, and I didn't relate his business friends. We were living more and more apart, he had his business world and I had my home life.

I started doing A-levels and falling in love with my psychology teacher who equally fancied me madly and even though he was getting married tried to have an affair with me. I was madly in love with him, fantasised about him all the time and was completely absorbed by this. I think I'd displaced my feelings on to him so as not to feel what was really going on, which was that I was in an outrageous situation with a man who was just taking care of himself with no regard for me at all. Suddenly this world of men who I felt I had something in common with, opened up; men who were interesting unlike the dead duck that Fred was. I got into yoga, and I think that absolutely shot my energy. All hell broke loose and I had visions, saw things, and became very, very psychic.

I was sure Fred was having affairs, but he was still denying it and it wasn't until the day that we decided to divorce that he told me the truth. The way he told me was, "since we are splitting you know I might as well tell you". I could not forgive was that I'd been lied to and had been thinking I was going mad, we had rows all the time

and I had been living in this sort of no man's land with him. He even told me that his secretary had said to him "why don't you tell her?" She knew me, I knew her, I had her in my house sometimes I was invited over to her house. The thing is if he had told me before then we would have begun a new journey, we might have had a marriage, but this way nothing was possible.

His response to my wanting to split up was to go on holiday and have a nice three week break without me and the children. We never had any money, but he could do that. He had just started a new business, was going freelance which was a big stress and money was always an issue between us. However he went ahead and bought a boat for thousands of pounds lying to me about it. This is what he did; he did what he wanted to do, he got sex when he wanted it with other women, he bought himself what he wanted to have, and I was just made to feel like I was this person who was overspending.

Then he did the nastiest thing; I was so angry! At the time when we were discussing separating and when he was away on holiday my mother came over, I went shopping with her and bought myself a dress on our joint credit card. When he came back he stopped he took me off the account. This created terrible problems with me later, when I needed my own credit card. I was so angry I made him write a letter to the bank saying he apologised for this and was taking it back, that it was just because we were getting divorced.

Later when he realised I meant business he got frightened he suddenly wanted to change things and became more willing to accommodate me. He bought me yoga books, whereas he'd been very possessive and before I could never do anything without him spoiling it for me. I said "I need an au pair" so he allowed me to have an au pair and he let me study. So we tried and then eventually decided to split up I wanted a separation; I wanted him out. I wanted him to move out so I could have affairs. I wanted to sleep with men, find out what it was like and discover who I was sexually.

Fred immediately found himself a new girlfriend and they came to visit. Fred was very much bonded with me and he threatened suicide and all sorts of things. I was slowly letting go.

I remember once I spent a day on the boat with him and the children and I just cried and cried because that life with him was over for me. I knew I would never be able to go back to him. No that's not true; what I knew was that I had become another person and I didn't know how to be there with him.

Fred said "I want to know if we're ever going to get back together", and I said "I don't know". He said "I want to know. If you can't you can't say that that's a possibility then I want a divorce". So I said "I don't want a divorce I want time" and he said "well if you can't promise me that it's a possibility I want a divorce". I said "I can't promise you anything. I just don't know". So he pushed for a divorce.

I said "if you want a divorce you are going to have to do it. I'm not going to do anything about it. On what grounds are you going to divorce me?"

He said "well then I'll have to do it" and I said "yeah you have to"

I thought if that's what you want I can't stop you but I don't want it; and then he did it on the grounds of my adultery and I hadn't done anything until we split up. So we divorced, and then he met Julie.

Children Living with Father and Stepmother

I went away to India for 3 weeks to visit a man that I had an affair with, and the children stayed with Fred and Julie and that was the first trauma. I don't think the kids knew whether I was coming back or not even though I had told them I was. I think that was quite difficult for them.

Julie didn't have children and Fred didn't want more children. I think that he had an attachment to me so that his and Julie's relationship never stood a chance. Julie and Fred married in 1983. A year later the children went to live there.

Tom was twelve and Jane eleven when they were living with Julie and Fred. They were there for a year and then they went to boarding school. It was over a period of about two years when they didn't really have a home with me. I knew that things weren't okay because of how they had changed. They were normal kids before, they fought but there was no hatred between them. Whereas, around that time when I picked them up from anywhere in the car they would have these fierce rows that seemed to be about nothing. There had always been a feeling that the three of us were a family and we could do things together but when this was happening I felt there was no way. It was like something foreign to me was in the car. I didn't know what it was and I didn't understand it. I know kids row but this had a different quality. It was like life and death rowing, they were at each other's throat screaming at each other. I would feel totally taken by surprise, bewildered, and shocked thinking "Christ! What is this?" I vividly remember one time stopping on the hard shoulder of the motorway and saying "I can't actually drive with this going on. What is going on with you? I just know you two love each other. I just don't get it."

Then they both started crying and I homed in on what was happening "Hey this does not feel real to me. This does not reflect your relationship because I know you. I know what you are like and this is not something I am familiar with. What is going on?" I suppose I was reminding them of who they were and that they weren't particularly hostile to each other, they didn't share everything but they didn't hate each other. Then they both started crying and hugging each other and it was fine.

The issue for me in regard to Julie is only related to Jane. I don't even think of Tom my son as having had a , which is extraordinary. It makes me think about how important the genders of the child and are. I think that for Tom the issue was very much more around Fred his Dad. He's spent quite a bit of time with him because when he was about twenty one he had a flat on the grounds of his office and was renting from him. Fred was there every day in the week and although they hardly ever saw each other they did have a connection. It was a very different experience from Jane's who was much more involved with me and was leaning more on me than Tom was.

I took them on two holidays. One was to Gran Canaria for Easter, and then we had a month in Crete, which was lovely. We had problems particularly between Chris and I but they were the normal problems you have with your children, when the love is there. It was in Gran Canaria that I heard about the sort of things that Julie did. I was horrified and said "Listen. I don't want you to be in that situation."

For example, there was that day when she called them down and said, "Have you heard the story on the radio about the boy who killed himself and he was a heroin addict? You would never do anything like this would you?" as if they were heroin addicts who would kill themselves. Fred has a big piece of land and lives in the country and they told me that they just walked out, went for a walk together and decided that she was mad, so they had some solidarity between them. Julie turned them on each other. She used to humiliate Tom using Jane as an example because Jane was much more academic, but, she was also doing that to Jane, using other people's daughters as an example of how shit she was.

Jane and Fred's houses were always show houses, they weren't designed for children. Julie was like a House and Garden person. Tom and Jane each had their own bathroom there so they had all this affluence and luxury but there was no warmth. Jane got a call from Julie at boarding school absolutely doing a character assassination on her because she had discovered that Jane had used the wrong towel in the bathroom. Julie's behaviour was completely weird and usually revolved around how they as children were not appreciating her pride in her house. She was like a House and Garden person and her place was like a show house.

They weren't used to that as with me they were used to things being rather more messy but with warmth and love. We played a lot and did nice things together. I was definitely lacking in mothering skills but I don't think my house was cruel or dangerous. With me, if there were any sort of difficulties there was always the wish to resolve it on my part. So being with Fred and Julie it was a culture shock for them and I think Tom very quickly shut down. I don't know how he managed it (I must ask him how) because he doesn't seem to be tainted by it at all whereas, Jane has

definitely been damaged by it. She's got a little bit of perfectionism, which I think she had much more than Tom.

So Julie was trying to change the kids to be like hers rather than mine and it was awful. I don't think Fred was ever really nasty to them. He was just insensitive, emotionally dead, and didn't protect them.

In the beginning I thought "I am not ever going to say anything horrible to the kids about Fred. I am not going to turn them against their father. They need their dad. Whatever these two do is their business. I will do my business." I didn't say anything because I thought it was the right thing to do and that I was looking after them by doing that. Also I didn't take things up with Fred and Julie because the children would always say "Please don't talk to daddy about this. Please don't say anything." It was a bit like being bullied at school, they didn't expect anything good to come out of it. I did say things however when they went over the boundary for me like the sort of stuff I just told you about. Now I have almost flipped to the other side and I have nothing good to say about Fred. That's more refreshing and with the kids being adults we can laugh about it, but it's still not alright.

Relationship with Children Now

The result of it all was that the children were unprotected. It makes me want to cry now because I can see in both of my children the damage that did. I don't think they would have ever been the most confident people, but I think they wouldn't have had the sort of social nervousness that they had and I think they are now growing out of; Tom definitely is. I spent the evening with him the other day and he told me a bit about how he is at work and he is really finding his feet. It was lovely. He is still shy, and in many ways much more open than Jane, but he has definitely a strength which I think is more solid than Jane's.

Jane is much more sophisticated socially and she knows how to be with people, but, she's quite fragile inside and at the moment that fragility is really coming through. She doesn't have resilience to the sort of things that are a part of normal social life and the world. Of course, I don't have that so much either so it might always have been the case with her but without her relationship with Julie I don't think she would

have had the perfectionism that makes her obsessed about the world. She idealizes people very quickly and then when things go wrong then she has no territory to say anything because in her mind they had become perfect.

I think Jane had this injection by another person – Julie -who was basically poisonous, but the poison came with a certain kind of glamour and a bit of power, because Julie was extraordinarily well-read. Jane was admiring of what Julie was even though in some ways she wasn't actually anything. She was very well read and literate. Her degree was literature. I love literature and used to read a lot, that's not the point. It was the way Julie would talk about it. She was very intellectual. I am not like that. I am much more intuitive. So Jane has gone down that path much more towards her. Its not that I'm uneducated but all Julie cared about was knowledge. She used to say to the children that reading fiction was pathetic and a waste of time. You can see how she was the antithesis of what I am. I guess Jane got abused really as with Fred she had no emotional connection that could have helped her to see what Julie was really like. I'm wondering whether if she hadn't been there for two years and I hadn't abandoned her to them she would have a slightly different stance now

I have been very angry with Jane because she deflects the relational good-will signal in a message if it's not completely wonderful for her. It's not even that she doesn't get it, I feel (sighs) that she rejects it. I know this is never going to change with Jane and it pains me that she can't see her longing. She becomes infused into the world of the rich. She would never, never admit that but it's blatantly obvious that she has an issue around wealth. She likes to take her friends to Fred's because he's got a big house, a swimming pool and that kind of thing. Jane doesn't know who she is and who she wants to be. Does she want to be a woman who belongs in that world or a woman that belongs in my world? And the two will never meet. Now Fred's got a new girlfriend who is another stepmother, if you like. She's not a mother to Tom and Jane of course, but Jane has got really involved with her like she did with Julie. That relationship is definitely better. The funny thing is that Fred's girlfriend now is actually more like me but she's not me.

So when I think about Jane I feel an utter rage and it's really deep. I can't really explain it. I spiral into being aware that this stuff needs to be addressed. People need to become aware of the feelings involved. Talking about it stirs up absolutely everything. Everything gets acted out and I feel I am numb on some level. I am quite bewildered by my physical feelings actually. Its hard to work them out.

Fred is dead in some way and in some ways he's dead to his children so the relationship for both of them with their father is extremely sad to the point where I sometimes just would like to undo everything, to roll the film back, not have the children and not have the match. Its absurd because I wish I'd never married this man Fred, so that my children would have a better father, but my children are his children. What I wish is that they would be the children that I have and Fred would have pissed off or died, or I would have left him earlier, found a nicer man, and they would have had a better input from me and a nicer man. If I'd had a partner myself I wouldn't have let the children go and they wouldn't have had this experience. I would have felt stronger in my own position. That's what I would have really liked for them a stepfather; the sort of man that I would be involved with now. There was this young man, I was involved with for a year and we had an amazing time, they blossomed totally in that year, but he was only 19.

The rows that I had with Jane even just a few years ago were totally oedipal in that no matter how bad her relationship is with Fred and how much she complains about him, and how much she gets hurt by him she still wants the relationship with him. When he wasn't with anybody, after Julie died, it was like her opportunity to take the place. I felt devastated by what I saw her do and thought "No! No! No...! Please don't!" Fred was doing some really weird stuff, starting to talk about women in a bizarre way and saying to her "Have you see the Naked Muse?" She told me this and said "I feel really angry, with Fred". The anger that she was expressing to me was definitely weird, as if she was his girlfriend. I was so worried. I felt "not this on top of everything else, this doesn't help. It inflates her in some way but it doesn't help her to solve her issues with men", She was going through difficult things with her actual boyfriend Robert at the time as well.

Now, she is seeing a therapist and it's a bit like she has a . She talks to me about it and I don't know what to say, other than to encourage her to take a risk, stick with it and try something; but I don't see her do that. Julie hated me and would say things about me that were really poisonous and she was a very bright woman so she knew what to say that would touch the right nerve in Jane. She fed Jane's narcissism when it suited her and totally crushed her when she had another agenda.

So Julie put Jane into some kind of emotional bondage at a time when she needed to grow into her own identity and be able to have some arguments. Jane did have arguments with me but it never felt it was just me and her having ordinary mother/daughter arguments it always felt I was fighting her and Julie when we had fights. If it wasn't for Julie I don't think I would have had the kind of fights that I had with Jane. I didn't feel the need to fight my own daughter in this way I was fighting something else; Julie and not Jane. I never look at Jane and see myself. She's always been different, like she has more of Fred's genes and seems much more like that part of the family. I look at her and she's a woman and I'm a woman but I don't feel so much that I am looking at myself. For some reason Julie didn't get into Tom in the same way even though he is the one who had more problems at the time. He and I had a much harder time when he was younger, but now we have a much cleaner bond.

So I am trying to reflect on what Jane and my's relationship would have been like if there hadn't been Julie around. I don't think it would have been the same because I would never have felt guilty about leaving her and threatened by her taking up such different values. I imagine we would have had a relationship that isn't so complicated. I think we would have had similar issues, but that I would be clearer with it and might have even risked more anger and firmness with her. I always feel conflicted between being absolutely furious with her and almost wanting to say to her "You know what? I've had enough of you. Get yourself sorted out. I am not willing to tolerate this anymore." and, wanting to gather her in my arms and say, "Listen sweetheart, I love you and just don't worry about anything. "

There's a part of her that's so little. I saw it again yesterday; she broke down crying, I gave her a cuddle and it was like holding a four or five year old in my arms. It's really difficult. She's thirty three but she looks really young and frozen at the age when she went to Fred and Julies, slightly pre-puberty; and she looks more like that since she lost a lot of weight.

Synopsis

I tried so hard not to be nasty about Fred or Julie I was a bloody saint! I really was! I never said a nasty word about Julie I was trying to be friends with her until it was blatantly obvious that it wasn't going to work. I think she tried as well actually. I don't think Fred helped, I think he forgot the children somehow whereas I don't think I ever did. I had a pretty strong maternal feeling about them but I didn't have the skills to put that into action so I didn't do a lot of things I would do now. If it were now, I would have it out with Fred and Julie in a sober way; I would feel more confident. But then I basically thought I was a bad mother. The thing is if your children have an experience that is antagonistic and has destructive will towards the parent, then it's going to have an influence.

The children had au pairs until pretty much about a year or two before they went to stay with Fred. I had one au pair I threw out because of how she behaved towards Jane. She was a sort of Julie type and I actually threw her out of my house. It was terrible; she was howling because of what I said to her. I told her I didn't want her to treat my daughter like this and was absolutely clear about what I was and wasn't going to have in my house. I didn't have that clarity when it came to Fred and his wife though. I felt frightened that if I made too much fuss then they would take it out on them because of some of the things I'd heard. The children would have been in the middle and I was very worried about it. I didn't want them to suffer. I was selfish and immature and thoughtless but I really didn't want them to get hurt, and of course they did.

I was so psychologically unsophisticated in those days I don't think I explained much to them about why I had left and what had gone on between us because they were so young. When I think about it I know I did the best I could at the time, but,

it's just so sad. They are two people who I love and I want to be alright. Tom I feel really lets me in but with Jane I can do very little. I feel that that place where I might have been able to do something for her has been taken up by Julie, and Julie died and has become idealized. Jane doesn't talk about it very much but I know deep down she's idolized her and it makes me sick. I feel that perhaps if she were to talk to me and tell me how she loves Julie and I could show her that it's alright with me, she might be able to heal some schisms. But I would need for it really to be alright with me to be able to do that. I wish I could. I have had moments where I could.

I remember Jane telling me about having a dream after Julie died when Julie visited her and told her she was alright, so she's got a bond with this woman; a spiritual bond that I don't understand and it doesn't include me. It feels very painful. I have been able to see how deep down Julie wasn't evil she just was unable to see what was needed in the situation as was I.

The children should never have been forced to love her in the way they did me because that's not right they were always going to be different. She couldn't accept the difference at all and she tried to re-mould them into what her children might have been like. If you look at the photographs of them in their dad's house it's pitiful! The kind of clothes they were wearing were unlike clothes they would have worn with me. In the photos Jane stands like she's been put in straightjacket all neat and in prim dresses. She looks like a prim little girl and she's not like that really. She wasn't dressed like this with me. Fred of course was taking out all his hatred towards me because I'd got rid of him and was ridiculing what I was doing and who I was and saying that I had become a hippy. Nobody thought about what it would be like for the poor little kids to be treated like this.

If I had understood it better at the time then I wouldn't have been so reactive myself. (At the end I did become quite reactive in the end and had rows with Fred and Julie in front of the children). I might have been able to talk to them or say, "OK, you are going to Daddy, what do you want to wear?" and made a conspiracy with them. But at the time they were at the mercy of these mad adults who were acting out this shit.

Normally, I don't walk around feeling like this. I feel that they are great kids and I'm just so happy with both of them; but I think that is always from a place of knowing how we started and thinking, "Wow! We've come a long way and this could have gone a very different route" Given the difficulties they've turned out to be really good people; both of them; they are lovely people.

I think I am so aware of what is going on with Jane because I saw her last night and she was in such a state. I was happy about her having therapy and now the same old thing is starting again; it's the same wound.

I feel like saying, "Don't listen, Jane,?"

I can't quite communicate with her because (Tom would understand immediately what I was about to say) she's sort of deadened on that level and doesn't get that it's not about whether the therapist is nice or right or not, it's about whether she can take the risk to find out. She hits the same place again, and again, and again, and again and it's the place where she's terrified and doesn't know it. I attribute a lot, to what happened with Julie because Julie didn't know how to relate to a young girl and had no softness when Jane was at an age where she was feeling terribly vulnerable, abandoned, and probably traumatized.

I know that the fact that I am not having a normal relationship, meaning I am not nicely settled with a man I have known for years is a problem for Jane. I think if that were the case Jane would see me in a different light whereas at the moment I am a spinster. She wouldn't say that directly but I know that's what she feels. She says it in so many ways.

Now I am wondering "What would it have been like if Fred had of been with a woman who was really nice?" and in all honesty I don't know whether if I would have coped any better; I might have felt very threatened by that too? I didn't feel threatened by Julie at the time because her being so outrageous consolidated my position. I felt that this woman could never take my children away from me because she was getting it so wrong. But in doing that I think I denied and deflected the real threat that Julie posed in my relationship with Jane. I thought she was getting it wrong and therefore was no danger.

I can't conceive what it would have been like if a woman had got it very right, you know, There's a bit of that happening with Mary now because she is in a different position and the relationship she has with Jane, I think, is really nice. I have to say I don't feel as threatened by that, but then, you know, Jane is 33 and I feel we've got a bond.

The Darker Side of Mothering

So as far as I am concerned there is something very primitive and powerful between me and my children. They are part of me and I will never forget that they once were in my body! I think about that all the time. I look at Tom and I think, "God! this guy was once a bit of sperm and egg" I don't know that other parents do that. Maybe they do? You tell me. I do that with him and also with Jane. When it gets really bad I can turn around and do something horrible like "I've given you life. You better watch it! I could take it away from you again!" It's a feeling of, "You are always going to be my children." It's a power thing. Like it's the only relationship in which I feel I have some irretrievable, irreducible power! (Laughs)

So if Jane does something that really, rattles me in a way that feels dreadfully threatening I can think things like, "I have given you life and quite honestly if you don't behave yourself I am going to shove you back in the hole." Like I could kill her! I'd annihilate her. Its almost on an archetypal level like I've become this goddess the Kali that could destroy her. At that moment I guess that's also what she feels me to be. On the other hand I never feel anything like this with Tom. Our relationship is completely humanized, he's grown up.

There was one conversation with Jane which she refers to from time to time. She got it into her head that I had had something with Robert. I don't feel there was anything in that, I was so thrilled that I knew one of her boyfriends. But there was an incident where I saw Jane behaving with him in ways that made me think, "Shit! she's not going to be able to make a relationship last if she behaves like that". It was awful and something she still does. She battles with men intellectually in a way that I think is horrible because it really is against herself. I find it heart breaking, that's the truth.

So, there was something going on about a piece of cake and Jane was being very critical and I got a little bit on Robert's side at that moment in enjoying the cake. She felt terrible and with hindsight I understand that she felt betrayed by me. I can't actually remember the conversation exactly, but I said something quite cold because I thought it was authentic and I think it was a shock to her heart.

I think there is something in what I am saying about the relationship between mother and daughter. It is interesting that in fairy tales there is more often a stepmother than a stepfather. It's usually an evil stepmother and she is in contrast to a good mother. It's as if the good and bad motherly aspects are divided with the mother being good and the stepmother bad. I think it's quite possible that the stepmother holds a split off part of the mother.

The thing is that all parents on some level feel that their children are theirs. What shocks me about my own feeling is that I don't they are mine but I am conscious of this power that at times I feel I am exploiting. I have the feeling because I have the awareness of the powerful link not the other way round and it feels more awful. I'm talking about a biological thing that I was never really aware of but that I acted on. Now I am much more aware and it frightens me.

This is powerful stuff. I feel shattered and also I feel completely passionate about this. I have wanted to write about mother/daughter relationships for years.

Barbara

I've got two children, a boy and a girl and they've both got the same father. We've been separated for a long time and he's now dead. My current partner has got four children from two different marriages; two boys from the first and two girls from the second. The two eldest are both married, the eldest one's got one son and the other one's got a son and a daughter.

I was separated from my children's father when they were very young. My daughter was about 18 months old. I was then on my own as a completely single parent for about four years. As my daughter grew older she continued to have a relationship with her own father as did my son. One reason for that was that he'd come from a big Irish family and their grandmother was the matriarch of that family. She was a lovely woman who always maintained a relationship with me, the children and their aunts, so they have that family but they haven't had as much to do with my own family. I'm not separated from them but they didn't have really much of an impact. They live a long way away and we haven't had much day to day contact.

Family of Origin

My father is dead, my mother died when I was quite young and I had a stepmother who is still alive so I know about stepmother issues coming from the other side as well. My mother had multiple sclerosis for many years probably from when I was born. She was very, very ill; an invalid for a long time, so I didn't really know her and neither did my younger brother. My father remarried when I was in my early teens and then they moved home. My older brother got out as soon as he could. I didn't see him for twenty five years because he didn't turn up when my dad was dying and he didn't go to the funeral. Just recently I've been back in touch with him.

It was quite problematic at times with my stepmother although looking back on it now I can see how difficult it must have been for her. She was a class above and she didn't have children of her own. We were teenagers and she wasn't unpleasant but she obviously didn't know how to deal with us so we had quite a lot of resentment. She wanted the house nice and at one point she wanted the lounge for adults – not for us!

In those days most people left home earlier than they do now and I went to college as soon as I could. I left my younger brother at home and I think he felt rather, abandoned. He ended up marrying a Scandinavian woman who was eighteen years older than him and who was the mother of his best friend's girlfriend. They have just celebrated their thirty fifth wedding anniversary. At the time it was quite a scandal! When that happened I and my father maintained contact with him but my stepmother was the one that was really upset about it and, didn't see my brother for at least a year. Now, since my father died they live near each other and they have a very close relationship; they look after her really. My younger brother and I have these conversations when he'll say, "How old do you think Jill is?" I say, "Oh I don't quite know I guess she's about eighty now" But, it's funny, we don't actually know. It's not the kind of question you can ask.

Recently there was this family gathering with my Aunt on my mother's side; it was some kind of golden or diamond wedding thing in Yorkshire and my dad was hoping to go up there to visit. I thought it would be good to go and I took my partner who hadn't met all the family, so he was meeting all these people that he didn't know. He accompanied my stepmother and I suppose they were talking because he said afterwards that she said "I never had children of my own. I sacrificed that opportunity," because my father didn't want more children. That was something she'd never say to me and my brother. Sometimes people tell somebody they don't know very well these things. When I calculated and went back, I suppose she was in her thirties when she married my father whereas I had been thinking she was much older. When you are a teenager adults just all seem the same kind of age. She was younger than him and I hadn't thought about the fact that maybe she had wanted children of her own. It was an interesting insight into their relationship.

All I knew about my mother was she had been an invalid and in a way it dehumanized her; I never knew her as a person. But even with my father I never felt a real closeness; we had a rather formal relationship. My stepmother never tried to be a mother figure to give her her dues. She was a professional woman and she'd been on the stage as well so she had quite a scary aura. My father adored her. That's one thing, when you are a teenager you find a bit gagging; to find your father

suddenly doting on someone it's a bit yucky. But they did adore each other; they had little names for each other and things. It was very sad that he died; it was just when she was going to retire from work and they had plans to do things together.

First Relationship and Becoming a Mother

I realize now that I didn't have a role model as a mother and when I had my first child in the late seventies I didn't have any contemporaries with children that I could look at either. I did have one friend, who'd had a child when she was at university, but most of my friends were about five years younger and they were all deeply into enjoying themselves. They all lived in squats and were doing this and that. A lot of them had children later. I remember cycling over to my friend's squat to tell her I was pregnant and she wasn't really interested. I found the baby bit of having children, which some women say they find difficult, quite easy and I bonded very closely. I liked breastfeeding; I found that really nice and comforting. It's once they started to walk and talk and were into toddlerhood it became harder. If your friends haven't gotten children at that stage you feel quite tied. Actually this country has changed in restaurants and pubs. I know it's not like other countries but it's definitely become more child friendly. I get annoyed sometimes at lunch time going into pubs and it's like a crèche. God, the times I sat outside a public house in the freezing cold at some horrible place with broken glass having a drink just because I wanted to be part of the human race.

I was thirty one when I had my first child. I wasn't seriously young. In those days it was quite an old age to have a baby. I had this awful partner who was an alcoholic. He was an alcoholic who drank on his own, was completely unreliable and at times dangerously so. He was an alcoholic before I had the children I should never have had children with him to be honest. If I'd lined up every man for suitable father material he would come at the bottom of this list; he was completely unsuitable. Looking back on my life I can't quite understand why I did that. We were together a long time before we had children, but I knew what he was like. If I saw somebody doing it now I'd say, "Why are you so stupid?" you know? "Why would you?" But I had that first baby and I should have kicked him out soon after that really.

I don't know why I had children with him; I even thought it would be a good idea. One does these things! I think I generally wanted children, but should have thought "Well, if I really want children I better get rid of this guy and think about what I am going to do." So that was the biggest mistake of my life. Looking back on it I can't quite understand why I stuck with him even before I had the children; I should have gotten rid of him long before.

Ending First Relationship

At the beginning of a relationship you imagine change. It was obvious that he was completely out of control and that he was never going to do it. He never did change. All through his life he remained like that. His form of alcoholism was like he had completely no self esteem. With any kind of pressure he would drink. In the end he just drank any way. But, before, with any kind of pressure he drank. I was the main breadwinner, he occasionally worked on a temporary basis.

I remember a point when I was building up the strength to kick him out and he suddenly decided to teetotal. He managed it for about nine months and I got pregnant again at the end of that nine months. Immediately after that he went even worse than he'd done before. We were living in another house around the corner which I bought with a mortgage and I decided to buy this house because I wanted a garden. I had found this street and tried to buy a couple of other houses down it and they slipped through my fingers, so when this one came up I agreed to buy it.

Funnily enough I called my current partner who had been a friend all along to look at the house. He was in the building trade then and I only called him in after I had agreed to buy the house. I could see as he was looking at it that he was thinking "What the hell is she buying this for? And she's pregnant!" because it was in such a terrible state. This whole basement was derelict. I had to get a bridging loan and we had to get all this building work done before they'd give me the mortgage. This was all on my salary and I was going to have maternity leave at any moment. Looking back on it I don't know how I did it. I was doing all the sort of things you shouldn't be doing. My partner in the meantime was going ballistic and hitting the bottle.

I bought this house and we moved in and it was like a building site for years. Then, my son who was four was staying with some friends who like most of my friends slightly hippyish and who had a son the same age. They were playing out in the street and Dan got run over and had got broken legs. So, I had a son in hospital for six weeks, a partner who was going lunatic drinking like crazy this house that was half constructed, and I thought "I don't think I am going to be able to do it." It was one of those times where now I think, "God, how did I get through that?"

Stuart's form of violence; was verbal violence which can be almost as bad as physical violence. He was mainly completely self serving. Funnily he could have stitched me up financially in some ways, because he was my partner but he didn't. When I bought this house being stupid and lovey-dovey I wanted his name on the mortgage and he wouldn't put it on there. Another man might have thought, "Well yeah, that might be a good idea because..." I was so lucky that he didn't because if he had he would have had that tie over me.

One of the great reliefs for me when I finally kicked him out was to be a single parent. Before that I was doing the single parent thing anyway but I had this other thing to do which was to deal with him. I managed it finally when my daughter was eighteen months old. I remember it very clearly. It was something like Friday evening and I had come home from work. Stuart had been drinking. I could always tell when he had been drinking. Special Brew was his particular, amongst other things and he was so stupid that he'd hide his empty cans in a place that was obvious I could find them. I was trying to feed the children and he was going ballistic and threw a dinner plate at my head. He was shouting a lot and I thought "that's it". I said "If you don't stop I am going to call the police," and he didn't believe me. I picked up the phone and did call the police. Actually, it takes a long time for them to come. It's a dodgy situation, you've gotta think carefully. I had to call them several times. The police were a bit soft with him they let him go at the end of the street and he was straight back banging on our front door!

I think everybody's got a breaking point and that was it. He obviously thought I didn't have one because if you are really soft and forgiving and keep on putting up

with shit they think that's going to continue forever. It was such a shock to him that for a long long time he could not believe that I would not at some point let him back again because I was soft for so long and had always given in. I think to his dying day he thought I was going to come back to my senses.

Before that time I couldn't see a way out. I lost a lot of friends at that time. Who could blame them, they thought "Why didn't she leave him?" It wasn't like we knew a lot of teetotal people who lived a very straight life. These were people who drank quite a lot themselves; people drank, they smoked dope. But, what he used to do if we were going out to see somebody was to have a drink first on the tube or the bus so by the time we'd meet anybody he was already halfway there. People could never understand, "Well why is he so drunk? He's only had one drink!" It was he'd because he'd topped himself up on the way. A lot of friends backed off because it appeared that I was going to stick with him. What could they do? People can advise you. But, I knew in my own head that because we were living in my house and I was paying for it I couldn't just take the kids and leave. I suppose in desperation I could have done but then it would have been very complicated. I knew that Stuart wasn't just going to pack his bags and say, "Okay I better leave voluntarily no matter what I did or said so I think that's one reason why it took so long. It wasn't going to be just a simple thing or a thing where I could leave the situation. So, it needed some sort of escalation like me calling the police to get him out.

Contact

Once I'd done it though, I wasn't going back. For ages afterward he was always trying to trick his way back in. He'd knock at the door and my son would answer and he'd get in and then I'd have him in here and try to get him out again. Things like that. I still remained quite soft in a way because I let him continue to have access to the children, which a lot of women wouldn't have done because there was several situations where he put the children in severe mortal danger. He lost them once at a festival. God, I let him have them for a weekend. My daughter was still in the push chair, I let him have them stay for a Saturday night and I went out to a party. It was lucky I came back because I had friends who had said, "Well you could stay at our house." But I said, "No, I'll go home." As I came down the street I could

see this big van parked on the street and as I got there it was a group of people who had been running the lost children's tent at a festival in Clapham and they had the kids in the van. I was so lucky; they really should have handed them into the police, but they managed to work out from my son's description where he lived and then they'd driven here. They could have taken them into care! On several occasions Stuart was really sketchy with the kids. But, I continued to let him have access.

He wanted to continue seeing the kids and my son really wanted to see him. My daughter was too young and, sometimes she didn't want to go. I did it for my son's sake, but Stuart could be very upsetting because he could either not turn up when he was supposed to, or turn up so drunk that I wouldn't let him take them. I think it was difficult for my son because considering he was so adoring of his father, his father could be very cruel to him. He would taunt him because he wasn't that good at school, or just for any reason, but they did have a bond; they have the same sort of sense of humour. . I am quite pleased and I think the kids are quite pleased that they did have that relationship with their father. I always thought it important that they knew what he was really like otherwise they could build him up to be some heroic figure. My son still misses him; he was the one that nursed him at the end when he died. The only person he wanted to see was my son at the end

Current Partner – Stepfamily Issues

I got together with my current partner when my kids were quite young; Helen was about six and Dan about eleven, but we lived separately until recently; so, although he was around when my children were growing up it wasn't the same as if he lived here. I met him through his first wife who I knew before I knew him. I introduced Andy to Robin his second partner because she was a friend of Stuart's sister when I went to school, so Stuart had known Robin, since she was five. Andy didn't want to be that involved with my children because he already had a whole selection of his own. I thought it was a good thing at the time. You start a relationship and don't know quite where it's going and I didn't want a succession of different surrogate fathers. But looking back it wasn't such a good thing because it was neither one thing nor the other.

What used to happen was when my partner had his two youngest children for visits at weekends and things they would come and stay here; so he was here at weekends with his children. They came because I had a nicer house than him and his kids liked coming here. He shared his house with another man and it became like a series of rooms of bedsits whereas mine was a family house. All the kids got on well together. We used to mainly do holidays together as well. Looking back on it I was a bit too soft on that front.

When you are a single parent; a mother, it's difficult just organizing things and getting through life. All the day to day and bringing up the kids decisions, were mine. Occasionally Andy'd come along to the school if there was a play or something like that. I think I got tougher as I got older and I've said to Andy that I should actually do with more help. I was far too understanding before, and did most of bringing myself to be honest. At the time Andy was working as a builder and often used to work weekends including the weekend he had his kids so I would end up looking after them in the daytime as well as mine. I've said to him "that was madness, what should have been happening is that you should have been having all the kids, my kids as well for the weekend because I was having to deal with them all the time"; A lot of people would say 'forget that, I'm not doing that, you should be doing this, this and this and I was a bit too soft and forgiving in my relationships; too willing to bend to accommodate, whereas maybe I should have been strong. But then I guess that's a personality thing. Now if he said that now I'd say 'well you don't have to' if you're a mother you just have to say 'no I can't work weekends'.

There have always been some issues between my daughter Helen and Andy. She was quite young when we got together and she wasn't attached to her own father. In contrast her brother, the eldest, was always quite attached to his father despite the awful things he'd done. Andy would be in and out. The way she describes it now is that Andy didn't really engage, and then when he had his own daughters here she felt a bit left out; she felt Andy would concentrate on them and not her. She's actually always got on really well, particularly with the youngest one, Erica. It was more about her relationship with Andy. She wasn't as close as she would have liked to have been. Also Helen and I had spent a lot of time together and she used to get

jealous of Andy because she had this bond with me. I feel I should have insisted and said, “Well, if we’re together we should have something more of a relationship here.” If we had talked about it and worked it out it might have been different. But, I think they have worked it out now. There’s always a chance for them to fall out though. In fact, they had a big bust up just before Christmas. It was over something really stupid like the bathroom. You know, that’s what big family rows can be about, can’t they? Something really stupid.

Dan missed out on a lot because by the time I was a single parent he was expected to do lots on his own and become quite independent. You know what it’s like when you’ve got two and one’s very little and you’ve got to put them to bed and he used to miss out sometimes on me reading with him at night because I was putting his sister to bed or something. He’s got a very different character from his sister; he’s quite forgiving but he also had issues with my partner. Dan quickly became a teenager after we got together and was a typical teenage boy; he and I would clash all the time. He was sulky and difficult and was truanting from school all the time. I tried and tried but I couldn’t get a handle on it. In retrospect the way my partner dealt with that was really bad, but he was doing it for the best reasons. He thought he was defending me by going for my son and then in the end he suggested we challenge him. Dan was thirteen maybe fourteen and at the time was always saying, “I’d rather be living at my dads!” so Andy said, “Well, why don’t you tell him to go and live there?” To give my son his due he was very strong willed. A lot of kids would say, “No, I am not going I was just saying that!” but he felt he had to go because we’d called his bluff. So he went to live there for about three or four years although he did eventually come back here. In a way it was a relief when he went. In some ways living there for him was good for him but his alcoholic dad was living a rather sort of weird life. Dan continued to truant from school so that wouldn’t have made much difference whether he was here or there.

Andy and I have talked about it since and he agrees that he was pretty horrible to Dan. What my son really needed was a decent father figure because his own father was completely dysfunctional and we didn’t give him that. I feel very guilty that I wasn’t strong enough to defend him. I think he was probably dyslexic or had

difficulties at school which because I was so busy working and trying to run the house I never addressed properly, so he ended up leaving school without any qualifications at all. I would have thought that he would be the one who would have held resentments but now, interestingly my partner and him have a very good relationship.

Me and my partner don't have kids between us but we've each got kids and I found that I was completely torn between my relationship with him and my children. When my daughter reached teenagerdom and there were clashes between her and my partner I found that I always ended up being the one in the wrong. They would both blame me because I was trying to skate between them and of course then you never satisfy either party. My daughter would say I didn't stick up for her enough.

It used to really annoy me when my kids were behaving badly and I knew they were. Sometimes when your kids are behaving badly you don't want other people to witness it. My partner would say I wasn't tough enough with my children. I found it very difficult that he said that because he didn't live with his own children and the parent that doesn't live with their children gets the benefits of holiday and weekend visits but doesn't have to deal with them day to day.

Andy had a close relationship with his two eldest when they were young and he lived with them, but not so much when they were older and he had separated from their mother. He was tougher with them than he was with his daughters; his two youngest. But he never saw his own children behaving badly, particularly his eldest daughter. She went through a phase where she was absolutely awful, but according to him she was never quite as bad as my children were. It was because he never witnessed it, he was never at the end of it. He didn't have to deal with that the day to day grind where your kids are behaving badly, in the morning when you are all trying to get out to school or work and in the evenings; all that kind of stuff. He had their mother going on about it but I think if you don't live it it's quite hard to understand. If you are witnessing other people's families you are likely to say, "Oh, God, well why did they do that? What are they talking about?"

I didn't feel that I had any say over what Andy's kids were doing or anything and that was fair. I guess if you are two families together it's always a bit complicated even if you are not partners. If you've got two adults and there is a group of children then one adult is dealing with their children and the other is dealing with theirs. If things go wrong it can get difficult between the adults. It depends whether you are working to the same values. Andy and I were doing that overall, but when one adult is dealing with their children the other one tends to always think they are being a bit too soft with them and vice versa. So I thought Andy was too soft with his own kids and he thought the same with mine.

I think for mothers particularly your children are a reflection of you. It always seems to be the way that they can be very charming when it doesn't matter much and then you take them to a relative you haven't seen for a long time and they seem to do everything just to make it difficult and you think, "Well why? Why did you do that thing? Couldn't you have saved that until we got home?" Now, I don't have young children and sometimes when I am out and about and I see kids playing up thoughts flip through my mind like, "Why are they letting their children do that?" I realise that it is easy to forget, even though you've been there yourself.

You have a particular relationship with your children. Everybody does don't they? And you learn in your family how to deal with things don't you? Somebody from the outside might think what you're doing looks a bit balmy what you're doing, but you've learned how things work best for you as a family.

Now the kids are all adults things can be addressed. Usually each time we have a few drinks at a family gathering my partner and daughter have an issue and then make up. My daughter is very, righteous and verbal and can get mad at everybody. Her brother says "I love my sister to bits but God I wouldn't want to be her boyfriend!" but they can all still have their moments. All the children, mine and his, get on very well together. They enmeshed so that we have become a family, although there are differences. The latest set of problems have been all with his children which was a relief to me! Sometimes you think, "Phew, at least it's not my

kids causing the problems this time!” But then it’s more to do with Andy and his ex-partner their mother. I can express an opinion but they are dealing with.

My son hasn’t got a family himself and he hasn’t had a girlfriend for a long time. I worry about him a lot. He’s got very low self esteem. Both my children can get into serious depressed states; Dan particularly and I realize all through his teenage years he was really, really depressed. It’s difficult I don’t know if I would have been able to do much about it even if I’d realized. Possibly because of his low self esteem he has a tendency to drink too much, which for me is a concern because it could be in the genes. All that side of that family drink a lot. This year he’s seemed more settled than he has been for a long time but I worry about him more than my daughter, although he’s the oldest. I think possibly because he’s dealt with his father he’s a very understanding and forgiving person. My daughter was depressed in her teenage years as well. I tried hard to get her help but it was really difficult to deal with her.

One benefit my children have had from their upbringing is the collection of friends I have – a lot of whom, we met through their father. One thing he did have was charisma when he was younger and he always met or found people. My friends aren’t all the friends he’d picked up but there’s a whole mixture from that era. They’re kind of alternative people. Most of them now are doing straight jobs and living a straight life, but a lot of them don’t and are living interesting odd lives. So my children have seen these oddball people through their childhood and are quite understanding of people. It doesn’t throw them if people are a little bit different; that’s what everybody says about Dan within the family. I think everybody likes him in particular because he is good with the little children, he’s a nice person and doesn’t have any issues with anybody within the family.

Our family Christmases were initiated by me early on. When I was first together with Andy Christmas was difficult because he would spend it with his two younger children and his ex Robin, and I would spend Christmas with my kids and sometimes some friends. Occasionally I spent Christmas with Andy’s first wife the one before Robin which is quite odd really. When we first started doing Christmases together

we used to have this thing where he would go up to see his kids at Christmas and I would have it here and I thought, "This is a bit silly," so I said, "Why don't we invite Robin and the kids here for Christmas Day and we'll have one big Christmas?" So we started doing that. The first one we did we had Robin and her kids and his first wife over.

It was great when the kids were little cause they really liked it.. It's always nice when there is a gang of kids and they got on and they'd see the adults getting pissed and they just did what they wanted to. It would be nice! There was never any rows or arguments on Christmas Day, amazingly enough. It's funny because I used to go back to work after Christmas and everybody would say, "Did you have a good Christmas?" I'd say, "Yeah, we had round both his ex wives." They said, "What!?" To be honest, I don't think he's ever quite realized how lucky he has been that everybody has been able to get on because not many people would be able to do that.

Typically there would be my two children, his two younger ones, depending who was around with his other sons. At various times they were living abroad but if they were around, if they had a partner they would come. Then we reached the point where Robin got remarried so her partner would come along. I think he looks on completely bemused. I always feel sorry for him because he hasn't got any children of his own. He is being a stepfather to Robin's two but he is probably thinking, "What am I doing here? My wife's ex partner with all these people!" It got a bit much after a while. There's usually fourteen of us.

Stepfamily Now

When we have the big family thing Andy likes to play the patriarch, and its fair enough but, sometimes I feel subsumed because it's all his side. Me and my two children are a unit within our bigger family and sometimes I have to remind him of this. I say, "Well from my side, it's me and my two kids! I know we have become a whole family but I don't want to be completely subsumed by your family cause we have our own family as well. I don't want to just be an add-on to yours, so remember that."

When I think of the whole family it's quite complicated and there are a lot of issues going on, especially when you begin to get in-laws. It started to be about partners, the two daughters-in-law. Andy's first wife who is the mother-in-law to these two doesn't get on with either of them for different reasons. Luckily we were away last Christmas because there was a row between son number one and daughter-in-law number two which escalated. She's a bit strange and she comes out with some funny things. She thinks Andy is very rich, possibly because her husband at one point told her that. She's got it fixed in her head and she sees our big house and she thinks we're rich. She thinks we should be more generous!

I get very annoyed with Helen sometimes because she can be really harsh with me and I have to bite my tongue. She gets a serious case of the verbals is very righteous and always knows what's right and what's wrong. She's always very clear in her mind of what's right and speaks her mind. It's very dodgy ground to get too righteous, you know! It's all very well if you've lived a very righteous life! She can also see offense where there isn't any intended. Andy pretends that he's mister affable, and he can be Mr. Affable, but particularly when the kids were younger he had a definite way of saying things and doing things to wind people up.

Erica is Andy's youngest. Her and my daughter get on really well because they were always the two youngest in the family. They were the ones that continued to come on holiday with us. It was her birthday in the summer so she rang me up; she wanted the party here and said, "I want all the family." At this point there was still a conflict with son number one but Erica said, "I want them all there. I'm going to contact them and they'll have to come because it's my birthday." It's true they did and it was really nice, everybody had a good time, and the two that hadn't been speaking managed to be civilized. I was very complimented that Lucy wanted her party here. So, it's funny, even though they have conflicts amongst each other sometimes, if they are all here at a family do they all manage to behave themselves; probably because it's probably neutral ground for everybody.

We had a really nice time in the summer. We've got a little house in France we've had for a long time and Andy and I decided to go for about six weeks this year. All

the younger members of the family said, “We’d like to come.” So, I said, “I am going to arrange it. If you are coming I want you all to come at the same time not spread yourselves out.” So, they all came out for a long weekend. They got on the same flight, and that was my two plus my daughter’s boyfriend and Andy’s two daughters and their boyfriends. That was six of them altogether and we had a fantastic time. Luckily they had two boyfriends who could drive because none of them can so they arrived in two cars and we all went shopping in the market and bought loads and loads of food. What is nice is that everybody had a role. They were barbequing and my daughter’s boyfriend is a proper barman; he was mixing us fantastic cocktails. We had a wonderful time; e partied for about three nights, barbequed, ate and drank and all got on really well.

I think I’ve got quite a strong place in the family. For one reason, all the family gatherings have been at this house. Even when Andy’s kids were younger they didn’t want to stay in his house which had a maleness to it and they liked it here. This big kitchen was always a meeting point and I was renowned for my hospitality and cooking. If we have a family gathering it tends to be here. Sometimes I used to put my foot down and say, “I don’t want it here I’m tired!” but now we’ve accommodated it and I quite like doing it if it’s not at actual Christmas. I don’t really want to do another one of those because it tends to go on too long. People are here for Christmas Day and they stay over, then there’s a feeling that you should be doing something on Boxing Day. Whereas if you just have a big day on an ordinary Sunday or Saturday you’ve had a family gathering but everybody else isn’t having one too. You go out and the world is functioning out there. It doesn’t close down.

There was a news item last week about Ian McEwan finding a long-lost brother or his brother found him. He turned out to be a bricklayer living somewhere and it was one of those rather sad stories where Ian McEwan’s mother and this guy’s mother had an affair in the war and she had a baby. Her husband was due back and she advertised her baby in the local paper saying, “Wanted, couple to take a baby. No ties.” and she handed over the baby at the railway station. But the sad thing was, her husband was killed before he came home and she married the father of the baby, the guy she had been having the affair with, and went on to have two more children;

Ian McEwan and another. She's dead now, but this guy was adopted and I think he only found that out quite late in life.

Then there was an article by Zoe Williams in the Guardian writing vis-à-vis the article about Ian McEwan. She said that her father suddenly announced that he'd had an affair with somebody and she had a half brother somewhere. It was quite a funny take on it. She said, "Yeah, another half brother. Well, that's to add to the one-fourth sister, the two-half sisters and the three step-whatever!" She was describing how they went to meet this brother later on. So, it sounds like they've got this very complicated family with step and half brothers and sisters

My kids haven't got halves, they've got steps, but Andy has two sets so they're half two each other and there are two mothers. We now talk about our family quite a bit, how it works and the dynamics. Andy and I say how bloody lucky we are because to be honest if you have a relationship and your kids don't get on it can cause a lot of problems and we might not have been able to stay together. In our case the children knew each other before we got together but I spent that long time on my own with my kids as a unit even when I was with Andy. I remember that as a time I really enjoyed. I was in my forties. I used to go on these holidays where I took my kids on my own. We'd just go off and do things. I think a lot of women feel quite strong in their forties; certainly I had that feeling of, "Well, I've dealt with this, this and this so I can do that. I can do lots of things."

If you've got a relationship and there's kids involved; if your kids don't get on I can imagine it being horrible, there would be always these conflicts there. But I think if Andy and I split up our kids would band together in other ways. They feel like family to each other and talk like that. My daughter is saying, "Yeah, I am going to see my sister." so they call each other brother and sister.

When you have kids you have to make that decision about 'are you going to force them to help you do this' you know, are we going to have that row again about washing up. You can have a half hour row about whose turn it is to wash a few dishes and then feel completely worn out at the end of it, or you can give up and wash the dishes up anyway. In my family there were rows about washing up that

were to do with fairness, whose turn was it, who did it, you know 'I did that and more then' you know, it was a family thing.

When I look at other families some people are very good at getting their kids to do things and they stick to their guns. I've met people and they have a rule and that's the rule and you stick to it, This is what I was no good at doing and once your kids know you're not going to stick to your guns you've had it. I always found that you make rules and then the rule would slide and slip and once you've done that the kids know they can get round you one way or another except for something really serious. Then it all becomes a bit murky and it depends more on what mood you're in rather than being able to say 'well that's the rule OK, just do it'.

I was too soft but I got rid of my first partner although I think a lot of people thought I would never get rid of him so I did do that eventually. So I was strong eventually. I reached my bottom line and I was able to do what I needed to.

Elaine

I have two stepsons called Lawrence and Gabriel, 30 years old and 28. They're both in long term relationships. Gabriel has two little girls, one who'll be 3 in November and the other one born this summer. Lawrence is planning to marry his girlfriend next year. I live with John who is their Dad, we have a son called Michael and he's 16.

My mother died this summer so I've been reflecting on the experience of the mothering I had, and on being a mother myself. Her death was not unexpected, she had been ill for about 3 years and in the last of few weeks of her life she was very ill indeed, so I was well prepared for it. I feel ok about it in that I'm clear it was a good death, peaceful and on her terms, but it brings certain feelings into very sharp focus.

Family of Origin

In many ways my mother was a very good mother. Even by the standards of the time she was an incredibly unselfish person, positive, uncomplaining, sweet tempered and gentle. I think for me and my sister that was a difficult legacy because it set an impossible ideal. She was a very bright woman, a trained nurse, gold medallist, best nurse in her schools on two separate trainings. But as well as this in some way she wasn't very good. She could have done anything but she spent her life putting herself down, having to go along with my father and indulge him. In fact if she'd walked out on him with two kids she would have coped fine; she was the kind of woman who could manage anything she had this quiet strength which got her through things.

My mother had three small children and one of them was my father He wasn't grown up he was a small baby and he was a terrible father, absolutely dreadful. She could be positive about anyone. She didn't quite have rose-tinted glasses, but she was very naïve. She put up with a lot of awful behaviour from him without ever complaining, not even saying a word. One of her jobs was to reinterpret his behaviour to the world. Occasionally I would say to her how can you put up with this? How can you stand it? How could you? And she'd say to me, 'Oh well he's a very caring person

really he just doesn't know how to show it'. That's just a classic female defence; "this person is really alright and I can see the truth". However there was no evidence. He was violent; not to her but to us. She never raised a hand to us, so it was not that she thought that was an ok way to parent but she saw her job as being to support and protect him. I saw her having to live the lie of pretending that my father was this wonderful person who was everything she'd ever wanted, and that she was in a perfect marriage. In response I developed a strong dislike of violent, irresponsible men and I feel strongly about seeking the truth in situations. It's something about having an authentic existence facing up to facts and being real; looking beneath the surface and seeing what really goes on. I was clear that I didn't want to be in a situation like hers I wanted to find a father for my children who was a grown-up.

My parents' relationship was life long and I am terribly monogamous. John and I have been together 20 years next year, I've never been married, and I've never lived with anyone else in a sexual relationship. I've shared flats with women, but this is the only live-in relationship I've ever had so obviously I have a notion that relationships need to be committed and long-lasting.

In temperament I'm like my mother, I'm calm and not given to throwing things and smashing things and so on whereas that was an everyday occurrence in our house. The caring relationships I have had as mother and stepmother have all been with men; I haven't helped raise girls. So I've had to learn as I'm much more woman oriented and my natural instinct is to gravitate towards and feel comfortable with women. I've had fantastic female friends and a loving mother who was in some ways a bit off the wall, but a lot of the sort of, my warmth and tenderness are directly attributable to her; the bit that can care for a small baby and not be phased and can cope with the unrelenting nature of it all. I think that's her as a role model.

You have to look at the times. The women's movement was a very formative influence on me I was a teenager in the late 60s, the world was just bursting apart with changes, questions and different ways to live and I had choices that my mother and previous generations didn't have. It's not just one way of being for women now.

Being born in 1954, I grew up in an era where there was a mismatch between what we women were told and what happened in reality perhaps more than at any other time. We were being told that our future was marriage, being a wife and having children. Alternative role models were few and far between and were seen as outlandish and outrageous

I've got a questioning mind which is a great benefit to me in trying to puzzle things out and make sense of things. That was encouraged at school. The headmaster of my primary school said to my mother 'you must realise how bright she is. You've got to make sure that she goes to the best possible school'. My mother hadn't actually thought about anything like that but she said I could sit this entrance exam and I got in. So I became a scholarship kid to a direct grant school; a bright kid from a non academic family. I went to a school where it was quite clear that women could achieve amazing things. I was at school with people who'd had open scholarships to both Oxford and Cambridge. But all of that was seen as counting for nothing in those days, if you weren't attractive in a conventional way, you didn't have boys after you and all the rest of it. So all the time there was one message in one place and a message elsewhere and certainly in the world outside my school the ways you were supposed to behave were reinforced very, very cruelly.

Sister

In our family I was seen as the one with the brains and Susan as the pretty one, not so much by my mother, but I remember my grandmother (she was a silly woman) saying things like, 'when they come I can only ever see Susan because she's such a pretty girl'. What a thing to say about children! I remember my mother saying militantly 'yes well Elaine comes as well'. She was really angry!

Susan had the same choices as I had but she made them differently. She decided that relationships with men were what counted in life and she dismissed female friendship and the strengths of not being valued just for your looks but being seen as a whole person. She doesn't have female friends and that causes problems for women. I would say that it's a linear relationship; if you don't have female friends it's very difficult to survive life's ups and downs. That's certainly been one of her

difficulties. I don't believe that. I'm not dismissing the importance of having close confiding relationships with men, all the evidence suggests that people who have those survive better in life than those who don't but for women that's a two-edged sword. I think as women we're sold absolute nonsense about the nature of relationships, and how we can be happy and what matters. Very often we spend years and years trying to find the men who we can really talk to. There are women in their 60s who are still looking for that. So I think it's a blind alley for women but probably one that Susan is still going down.

Being an extremely good-looking woman was difficult for Susan. When she was younger she had a great deal of attention from men. I remember going to the cinema with Susan and this guy coming up to her at the end and saying "you're the most beautiful thing I've ever seen, I saw you sitting in the row I want you to come out with me, when can I date you" This was not unusual. As a girl I got a lot of attention from boys as well, I think maybe the nicer guys were more interested in me. There was a vote at Susan's school about who was the most beautiful girl and she got it. It was terrible really, terribly distorting. It sounds like it would be what every woman would want but for her it's been really destructive. Looks do count in life, but they don't count in the way that people think they do. Also beauty's very ephemeral it doesn't actually last forever; you don't look 20 all your life whatever you do, whereas intelligence lasts. Susan's been in a complete panic about her looks since she was about 40.

Susan had her kids taken off her by the courts for violence and abuse. She became most abusive of her daughters at the time when they were reaching adolescence; both lovely looking girls, it's a good looking family. It was so obvious that she saw them as rivals at that point. She has an appalling temper which I guess is something you can work on, but she hasn't. She is terrifying as well and that's very, very powerful. I've been very close to her children particularly to her daughter. They haven't really had much in the way of mothering, they live with their father. My sister sees them now because they're adults but for a long time she didn't.

My brother-in-law Julian divorced Susan. It was very high profile because in his field he's well known. He looked after the kids on his own, did a very good job for a number of years and then married again. His wife is another winner of the Zelda Fitzgerald award for emotional immaturity - another small bloody baby. I remember meeting her and thinking 'oh god this is going to be disaster' and so it has proved. She has done everything she can to exclude my nieces and nephews and create a new family unit with no reference to the past. All her conversations begin with her telling me how she is the most selfless, loving person imaginable and that I don't understand and appreciate what she has given to these children. Her line is that they have behaved so badly that she can't possibly have them in the house so there's a sort of exclusion zone and when Julian sees his kids he's got to do it on the side, he doesn't tell her. Susan got sent to prison for an assault on her which was in breach of an injunction. What's wrong with these people? Honestly! I'm surrounded by people who just can't seem to think straight about children, the interests of children.

My dear nephew is the one who has suffered the most and for whom I feel most concern. He said to me that he thought his mother and his step-mother felt like the same person at times and that's about right. His experience of mothering is so dreadful he doesn't know where he is.

My overall response to my family is that I never ever, ever want to live like that and I never have done. I'm good at not causing harm and damage whereas my birth family's full of people that cause terrible damage. Probably the fairest thing to say about my family is that they were fairly mad and a lot of what I've established is in response to that. I've been clear about what I wanted and didn't want; it took me ages to get there and involved a lot of work and effort. I'm with John because I want to be, and because he's an adult. I was in the role of parent and I took John on like that. I'm not sentimental, I've got no wish to rescue anybody or be a wife. I wouldn't put up with somebody trashing the place, or having a drug habit that we were all supposed to feed. I want a truthful existence and to care for children in an adult and responsible way without tying them up in knots.

I think I've got through because people warm to me I think people see me as fundamentally sympathetic and trustworthy. I don't think my sister excites that sort of response in people. I think people have wanted her for the wrong things.

In my family of origin I am like an island of sanity. I reflect on things a lot; it's a very strong part of my personality that I try and think my way through things. It's probably why I said yes to this interview and feel quite comfortable talking. I remember when we first met you said to me that this can bring up very difficult feelings. The answer for me is no it can't because I've had to deal with them anyway; I know them, I know this sort of stuff already because I've had to explore it otherwise I just don't think I would have survived at all. I've been extremely depressed at periods in my life (not so much now) but I've never lost

John and his children

When I met John I was in my early 30s and I'd just come to the end of an appalling four years with somebody who was the biggest infant of all time and which in retrospect seems quite nightmarish. He wasn't physically violent but he was incredibly punishing, abusive and unfaithful - a right pain in the neck. He was doing something which people who are fundamentally violent do all the time; he would treat me appallingly and I'd say 'I can't go on with this, I want to separate'. Then he'd get on his knees, burst into tears, say he couldn't live without me, would I marry him and all this rubbish. I came out of going round and round in that distressing relationship feeling 'I never ever want to live in any situation like that again'.

Very quickly after John and I met it felt quite serious. He'd been living apart from his wife for about a year and was clearly an attractive, intelligent guy who wasn't gay and wasn't messed up. Men like that in their mid-30s are at a premium. I remember thinking that I had to make a decision and commit myself because there were all these other women flocking around him. I went through lots of dialogues with myself about whether this was the right thing or not and this included his children because he was very clearly an involved, hands-on dad. It seemed to me that John was a very committed father and if I'd fallen in love with him then the kids

were part of the package. It was because I saw him as a really good dad and a positive parent that I wanted a relationship with him.

John's kids were ten and eight and he wouldn't introduce me to them unless he was sure that I would be a serious relationship. He took quite a while to do that, we met in the October and I met them about 6 months later. He'd had quite a few girlfriends and he wasn't interested in introducing his kids to a new quasi step-mum every week.

The first meeting felt a bit artificial. We had a picnic in the park and then went to the pub. John brought along a mate of his, his mate's wife and their children so that the kids had someone else to relate to other than me. It meant I didn't have a lot of conversation with them that day. Over time I got to see them more.

I knew that the fact I was on the scene did mean that everything was over between Eileen and John. It was over anyway but there's something final about somebody being involved in a new relationship. Even then John and I were talking about having kids at some point; kids of our own, so it was serious stuff.

John and I moved in together in August, so it wasn't a rush job but it wasn't very drawn-out either. Lawrence who was 11 had never given up hope that his parents would get back together. Lawrence felt really, really torn about his mum Eileen, although he knew that his parents had not got on at all. He had witnessed a lot of rows. He was a very feeling kid and held a lot in. When John said "I'm going to buy this flat with Elaine" he realised that was it, and although he said nothing at the time. I now know that he was quite distressed because it meant his father would never come home again. Gabriel on the other hand was positive and accepting and said things like, 'it's really fun being with you, dad can we see more of you?'

Before we moved in together John had a little bedsit flat. The boys were seeing him about three times a week. He lived close enough for them to get there, have a full day with him on a Saturday or Sunday and then go home in the evening. They didn't stay because he didn't have a lot of space. He wanted them to be able to stay overnight and come during the holidays and so on. However, when we got our place

John's relationship with Eileen deteriorated. I've never met her so I don't know first hand what her feelings were, but she went through a period of making it very hard for John to have access. She started to raise a lot of objections and said to John that Lawrence didn't want to see him, which was incredibly hurtful and wasn't true. This meant that Lawrence was caught in between; he wanted to see his dad but felt he was being disloyal to his mum.

I felt very concerned seeing John distressed. I didn't feel that Eileen was putting the kids' interests first because it was quite clear the boys both wanted contact with their father. At that time I only had the very beginnings of a relationship with them but I didn't take things personally in that I didn't think 'they don't like me and they've told their mother they don't like me' I just saw that when they were around with their dad they were very happy.

I am a social worker by trade. I've seen a lot of situations in which children have suffered most terribly in stepfamilies, usually at the hands of stepfathers. I knew that my situation with John had the potential to be a real minefield, so I set certain rules for myself to minimise difficulties; I wouldn't expect Lawrence and Gabriel to like me as I knew that there was nothing that would make them automatically do so; I would try to support John in his role as a parent, rather than trying to act as a mother and I would try to be a friend to the boys and get on with them in an undramatic and unforced way. We wouldn't have long chats about how they felt because I didn't think it would be very helpful to them. On that basis we managed pretty well. I do think they're very nice kids. The very few times that Gabriel was rude to me I certainly gave back. I wouldn't have accepted the no rules household or anything like that. But the boys were never impossible, they were never outrageous, they were nice to have around and they still are.

Lawrence was always caring and responsible. He tries to be fair and he tries to be grown-up. Gabriel I think is much angrier, generally, and he was very angry with his mother in his teenage years. She didn't have a relationship herself, and she clashed with Gabriel a great deal. More than once she threw him out and told him to go to his father. Gabriel was also angry with John but John was better at managing it

and had a lot more authority. So during the teenage years Gabriel was a focus of concern for his parents, but he and I rubbed along. I suppose that was because I tried to be supportive and didn't cast myself in the parental role.

Being a Stepmother

I think I was a pretty good step-mum; John says I was, and I feel that the kind of conversations and the ease with which I talk to Lawrence and Gabriel now suggests that they see me as quite a positive influence in their lives.

I think I was good at accepting all the children the way they were. I did always see my stepsons as very different from me, in that sense you are very bound up with your own child. Certainly in the early years with things like breast-feeding it's a profound relationship. Whereas my stepsons were always different individuals they didn't feel so intimate and were always polite and reserved, Lawrence is the most modest kid ever in the world. I wasn't allowed to see a bare back or anything like that. They had physical boundaries which I didn't cross. I was absolutely delighted when Gabriel, having been told by his father that I was pregnant, came and gave me a big hug. But those sorts of things were quite rare.

The boys were with us most weekends and quite a lot of the holidays. I felt that they were the priority and that we needed to fit round them. We had a very small flat and sometimes when they were there it felt like I was always falling over them, or their piles of stuff. I could have done with more space and more money and those sorts of things. Financially we were very, very strapped but in the end the settlement John reached with Eileen was that he wouldn't ask for anything from the house, but that she would give up all her claims to maintenance although he would pay money each month to the boys. She then went and claimed income support in her own right and the Child Support Agency got onto John, sent him demands to pay £1000 a month to her forthwith and said that the clean break arrangement no longer had any significance in law. Fortunately they retreated from that position.

So John came into the relationship with me with nothing at all. He had no capital, and he'd been living in a council flat which was the property of his former girlfriend, the one before me who, cos she was a teacher had been given flat to let in Tower

Hamlets. She then went and bought somewhere and let him stay in that place. So he had no capital, he had nothing. It was me who had the deposit for the flat we bought together and bought the furniture and that kind of thing. We never had a bean in those days we were very, very short of money. I never resented the boys about that but I did feel I did feel some anger towards Eileen. I thought she could get off her arse particularly when Michael was small and I was having to work part-time with a breast-fed baby. This was when the boys were quite big enough to be left alone. but of course as a feminist I should understand her point of view, which was that she militantly thought that John should be supporting them.

Money was a reality at the time; we were very short of money always, and I wanted to make sure that the boys got Christmas and Birthday presents from me. Even now I worry about money, but at least they're on their own two feet. It's been a motif of our relationship that I've worried about money and also have the main responsibility for bringing it in. I coped with it pretty well but I would have liked a bit more room, and I'd like not to have been so worried about totting up the bills at the end of the month.

I didn't particularly like what I learnt of Eileen. I've never met her. John and she have never got on to a reasonable footing, they've never been out for a drink together, it's been a complete divorce. I was only informed about what was going on second hand; the boys told me things and John told me things so I had this image of her which may be a bit unfair. What she did eventually to everyone's surprise, was she enrolled on a teacher training course and now works as a teacher. This was fairly late in the day. John's adopted mother used to say, 'oh she was a lazy girl. She was so lazy, she'd just sit around, she was bone idle' and his adoptive father didn't like Eileen at all. He was a very gentlemanly sort of man but he made it clear that he thought John had made a bad marriage. So it was all very negative.

Becoming a Mother

I was 35 when I conceived Michael, 4 years after John and I met so I was waiting a couple of years. By that time I was an awful lot more grown-up, than I would have been had I had children earlier. I know everybody takes time to mature but it took

me a long time to be adult enough to have children and not be taking out my own inadequacies on them. From the start with John I really wanted a child. Once we moved in together I'd have been quite happy to be pregnant straightaway but John was concerned about the impact on Lawrence and Gabriel. He wanted us to be a more used to living with each other beforehand but I was running out of time. I don't think that John wanted another family in those days but that he went along with it because he knew it was what I really wanted. If he'd fallen in love with somebody who didn't want children or had their own family it would have suited him better but he didn't.

When Michael was born John was completely bowled over. Gabriel was twelve and was terribly interested in his new brother. He sent him loads of presents and insisted on coming to the hospital straightaway. I think he loved having a little brother. I've got loads of photos from that time of them being together. Lawrence who was eleven, found it harder, he took a few days to come over. But they've got soft hearts these kids, they have; they're all soft-hearted.

I think in many ways John's really enjoyed this later experience of parenting more, because he's a bit more mature. Very early on in our relationship he said to me, 'I just wish I'd had the children with you' which is very sad. He does feel very, very negatively about his marriage but he doesn't feel negatively about us. He and Michael are closer than he is with his other boys.

I'll tell you what I wasn't very good at as a parent. I was never very good at playing mummy in the sense of I couldn't stand all the hours and hours and hours of building lego castles and things and making musical instruments out of used yoghurt pots. I was never any good at things like that and when the school asked me to do them I would hide. I spent a lot of time with him but we do things like go for long walks. Michael has grown up in that way. He's learnt to be quite self-contained and good at managing his own time. Only children often do have very rich internal worlds where they can just get on with it and although he wasn't an only child for a lot of the time when he was young he was the only little one in the house. So I wasn't a super-mummy or anything like that. I'm good with illness, I can keep children safe, and I

know how to give them a reasonable diet, but I'm not the world's most inspired child minder. I'm better as they get older because I'm good at letting them be, not fussing and letting them have a bit of freedom. None of the children are at all whingey which I'm quite pleased about. They were all brought up to get on with it and not make too much of illness, they can all swim and they can get cold without complaining and that sort of thing.

Quite a lot of times I would stick Michael in the pushchair and set out for a walk rather than play with him. When we lived in London we'd do things like trail round art galleries, which he seemed to quite enjoy. So I don't think I'm that unselfish when it comes to small children. I was very clear that I wanted sensible bed times, and that was partly for them so that they had a night time, a bath, cuddle and story and they went to bed. That was partly for them, but it was also partly for me so that I had a proper evening, and was able to relax a bit. Michael was a good a sleeper, but I would have used all my skills if I had to, to get him to sleep through the night, in the knowledge that if I was on task during the day then I was a better mother. But Michael was very easy to settle; he was very easy to satisfy. You could make him happy very easily which is a wonderful gift in a child I think. Michael had the normal things like proper food, proper bedtimes, he learnt to swim and to ride a bike, he knew his friends were always welcome here and he always had the right clothes to wear because we never did at home. But there were loads of things that I wasn't terribly good at.

I used to absolutely hate standing at the school gates, I loathed it. Most of the time I didn't have to do it but when I did! You see round here the kind of conversations you have with women at the school gates aren't the kind of conversations I'm into; I'm very ungossipy and I'm not competitive about children, so I don't want to discuss where my child is in the class or anything like that. It was rare that I found myself standing next to a mum who wanted to talk about something else. It was something about a particular lifestyle around here as well, where there are a lot of women at home with kids. Sometimes I just wanted a drunken evening with a mate, which we all do.

When I was little I remember those Mr Men books; Michael's name for me was mummy rush. Daddy was Daddy Strong. I was always running around, charging out the door...poor old Michael, but he seemed to survive it. I wouldn't recommend working as hard as I did, particularly when I got to Mind and discovered financial worry, but he knows he can rely on me, he knows I'm safe and he knows that men can care for children which I think is quite a good message.

If I'd been a stay at home mum I'd have been depressed. I would like to have been less frantic, have more time, and not be so driven by the need to pay the mortgage, but I could never have been somebody who organised the school fete, I'm just hopeless at things like that. I can assess wildly psychotic people and not turn a hair, but I can't do things like that.

I do remember that as being quite a hard thing, as my mother was incredibly selfless and I wasn't like that. She kept it up it didn't erupt in her running off in middle age or anything like that. She was always like that and she did it more or less without complaint. I say more or less, because she loathed cooking. She was a perfectly adequate cook, not anything fancy, but she fed us properly and well and it was home-cooked stuff, but she absolutely loathed being tied to the kitchen and making us three meals a day. She was a very bright woman and towards the end of her life when she was quite severely muddled she said to me, 'who's looking after daddy?' and I said, 'well he can look after himself, he's quite capable of putting a meal in the oven. He can manage on ready meals and things like that' and she said to me, 'you mean I don't need to do any more cooking?' and I said, 'that's right you have time off for good behaviour' and she gave me a beatific smile. So wherever she is I hope she's not cooking another bloody meal for anyone.

Relationships Now

When Michael was small I worked part-time, and that's what I thought I would do until he went to school. But then we moved up here and John was threatened with redundancy. The job at Mind came up and it just seemed a golden opportunity really because I always wanted to work for Mind. I applied for the job and got it, so from the time Michael was three I was working full-time and he started at nursery two

days a week; John did two days a week at home and he went to my mum on the other day. He was ready for that by then really.

Actually John and I split the work, I do all the driving because John's such a green activist he just sits in the car and rants about how dreadful a method of transport this is. He hardly does any driving anymore. He cycles everywhere, and I drive. If things need fixing around the house it tends to be me. But John can cook a very good dinner, and does, he has taught Michael how to play a musical instrument and is good at being there. He's more laid back and relaxed than I am, I'm a bit driven really. He'll sit out in the garden for ages just looking at things and relaxing, whereas I'm always rushing around doing things.

John struggles most with his relationship with Gabriel; it's always been a bit spiky; he's very close to Lawrence and to Michael. He's done it all from start to finish with Michael whereas with the other two he was a part time dad from when they were quite young. When he was with their mother he was the sole breadwinner and often doing two jobs. He also spent much more time at home with Michael than he did with Lawrence and Gabriel. When I worked for the mental health organisation I went back to work full time and he was the house husband so he did the long bike rides and that sort of thing. It meant that he had lots of time with Michael as a small child so they became really close, whereas Michael and I clash a bit. Partly that's to do with how he feels about being mothered at his age and he doesn't want to be told to do things. He talks more with his father about music and things like that, which John knows more about than I do.

I've got an awful lot of experience of chaos and madness. I know perfectly well that families aren't always good. When political parties talk up the family it's often complete rubbish. You turn over a stone in many a family and all these horrible things come out. My closest friend is a lesbian who's raised a son and she's probably the best mother I know so I think things often aren't what they seem.

I do worry about my stepsons sometimes particularly Gabriel, who has got family with the first real girlfriend he's ever had. They're both in committed relationships. I know that's what the world says you should do, 'you should be in committed

relationships', but I do wonder. I feel they haven't played the field. I think 'oh boys there's a whole world to see' but they seem happy enough. I think why they've done it is that both boys want security. They come from a broken marriage, they're fundamentally caring boys and they want to have stability. But also they're very much working class lads and that is the difference between us. They were brought up in West London and went to the local comprehensive. So the way they approach things in life is different from me. This is particularly true of Gabriel who sees his job as being this young man who's got to be responsible, bring home the money, look after his children and pay the bills. He's been talking like that since he was about twenty two with me saying 'oh Gabriel come and have a life'. Whereas Michael and his mates all want to go and travel America and have freedom that's not what Lawrence and Gabriel. I think it's a class thing actually.

But you have to respect the choices people have made. I'm very unconventional you know. I said to Lawrence and to my niece who married last year, 'what is it about you? here you have these role models where we try and tell you that you don't need to be married and you have to get married nonetheless'. I'm very anti-marriage I don't believe in fairy tales. I do believe in the importance of commitment and long-term relationships but I think there's all sorts of ways that that can be done. I feel that particularly strongly when children are involved. One has to respect that sometimes no matter what you do the relationship can't be patched up. Even then you have got to be committed to your children. In a way I'm an old puritan, I think people treat their commitment to their children very very casually and seem to walk out of one relationship and into the next willy-nilly at times, without considering the impact.

In our lifetime divorce has become easier and there have been more choices particularly for women. That's a fundamental freedom isn't it being able to get out of a marriage. Polly Toynbee (I think most of the time is a silly old bat and I find myself arguing with every article she writes) said somewhere that the right of easy divorce is absolutely fundamental to the interests of women; and she's right on that. But you do have to think about what happens to children. I can see that for my

mother it wasn't an option but then even if you plonked her down in today's world she'd probably not think about it either cos she was so selfless and so positive .

It's something shot through by class as well. People with money and connections have always been able to move around within the confines of marriage; men more easily than women. You just need to look at the Royal family and the kind of accommodation that's been made for their appalling behaviour. That's what did for Diana; that clash of expectation against reality. You know what really happened to a young, beautiful, not terribly bright girl in the Royal family, what she was expected to be and how accommodating she was expected to be. She was expected to produce her kids and shut up really and she wasn't having it. But women like that would never have a world stage would they? Pre-war there were women like her only they weren't getting interviewed on television.

All sorts of possibilities have come up for women, but in all of this we don't think enough about what children need and that is a hard struggle. Not always just doing exactly what you want. I'd never condemn someone for calling an end to an impossible marriage. I have friends who've been absolutely suicidal in their marriages but when you've got children the problems don't end when you divorce. I'm thinking about one friend in particular, I'm not saying it was all to do with his parent's divorce but this younger son of hers about the same age as Michael ended up in psychotherapy because he completely dropped out of school. He was physically sick at the thought of going to school.

So there's an awful lot to work out which is why we all need to try and make careful choices about the men we have children with. But I think I made a very sound decision with John. He's not a saint, or the absolute perfect person with no faults, but he knows how to care for children and I think that's a really crucial point. On the question of raising children he and I have never had an argument. We see absolutely eye-to-eye about what Michael needs, and on what Lawrence and Gabriel need.

I think two things are quite crucial in regard to children and they are; not seeing them as owing you things, and just letting them be themselves. Of course you want

your child to be ok and sometimes you look at the other kids at school and they seem to be sailing through; there's always some girl who comes top in all the exams. But Michael is his own person, has done things in his own time and seems to be coping pretty well, so you get what you're given. That was true of my stepchildren as well; they are as they are, and we have to adjust to them, as adults. Of course you set rules and have boundaries and all of that, but they don't have to be top of the class and things like that. We're obsessively achievement driven with children now even more than we were when I was a child.

You do hear an awful lot of negatives, don't you, about stepchildren. In my heart I don't feel any. I think they've only brought good things to me. I don't feel jealous of them but I'm quite sure that John would not have formed a long-term relationship with me

It has been a drive for me to care for children, but not quite the way you might expect, as I think I'm not a very motherly mother in many ways. As I said before I'm not good at playing with kids. I did admire all these friends of mine who spent hours sort of crawling around the floor putting trains together and so on. I did a bit of it, I was just never very good at it. I remember my mother reading to me as a child the same stories over and over, to a point where I could actually simply recite the whole story and she was endlessly patient about that. Whereas with Michael sometimes I felt like, 'oh Michael I can't do that again' and he said to me once, 'you're not very good at playing with me'; but he seems to have survived.

I work with families where the adults are quite afraid of children and stepchildren and sometimes there might be very good reason for that, because their behaviour is really outrageous and out of control. However it often feels as if it's the parent who is behaving like a child and can't establish authority. It might be quite obvious that an adult is needing to say 'well you don't speak to me like that and you don't speak to anyone like that'. People seem to hesitate with that side of parenting a lot. The other thing we see all over the place in social work is extreme violence perpetrated against children, followed by surprise that the child is acting out in a violent way. So it's some way of finding that middle ground where you do have authority.

The issue of authority is about being adult, and I don't think I would have had that at a young age. When I was in my early twenties I thought parenting was all about love, which of course it is, but it's about recognising that there are aspects of love, and setting boundaries is one. My sister is still just an infant really and she could cope with her children when they were very small and were very good and very dependent. That's the time when they look to you for everything. It's when they grow up and have a will and oppose you that it gets difficult.

Michael is really very independent now, but I want him to tell me what he's doing, like he's going round to Ben's, that's fine and if he's going out for the evening and doesn't want supper, I want him to let me know. But now it's a doddle. It's about the rules of living in a family that apply to anyone really. But Michael has also grown up so hugely this year, it's amazing. He's been doing his GCSEs, and he's done quite well and he's now, on the A-level route and is at college, not school. He sees school as too babyish for him now. He's just on the cusp of adulthood really which is really nice to see. I've talked all along about the centrality of parenting and how important it is to me that the children's interests come first but you can't live through your children either, so you've got to have another life. You've got to have interests and not just be living off your kids' reflected glory. They've got to be able to go away and know that you're intact.

I have found this a very interesting conversation. It does definitely lead back to my own experience of being parented, no question about that. I started by saying that my mother had just died and obviously all that is very fresh in my mind. But I don't think I've left out major bits. I'm very interested in what other women say.

One of the things I realise is that I've never really had long conversations with people about being a stepmother except in an entirely negative way with Julian's second wife, where they were all the devil incarnate. Among my close friends I'm the only so it's interesting thinking about whether there is any positive spin on it. Because I think very positively about it and the boys gave me a lot. I think the experience of being with them prepared me for having Michael.

It's a different relationship. For me the striking difference is the intimacy of the early years. Even with a fairly self-contained kid like Michael my memory of the first couple of years is this very intense physical experience of attending to his physical needs, the breast-feeding, the cuddles and the intimacy. I have nothing like that with Lawrence and Gabriel, and it wouldn't be right for me to because the age I met them was the age when children are beginning to draw away from parenting and a lot of boys really don't like demonstrative things. So I think that you have to find a way to establish a relationship in the first place very differently. It's all about being friendly but not suffocating. Whereas with Michael, even in times when he's been driving me mad I have the experience of having been his mother in the first place, with the shattering intimacy of those early months.

I think that's a real issue with adoption cos John's an adopted kid. One of the things that gets you through as a parent is that your children are flesh of your flesh you see. With adoption the whole thing is that they are brought up as flesh of your flesh, but actually they're not, and there are differences. It's better to acknowledge those than not really.

John's adopted mother is a very angry woman, but I do remember her looking at me feeding Michael saying, 'well aren't you lucky'? And of course I was; I was really lucky to be able to do that wasn't I? You know they don't need anyone but you in those early months and that's extremely intense. I don't have any experience like that with Lawrence and Gabriel. I've been very touched at the times they've hugged me. They both turned up to my 50th birthday party, and that was a tremendous effort for both of them, they don't live nearby and Gaia was very, very small, she was only about 3 months old, but they trekked up from Kent. In my speech I said something about the experience of children and how privileged I felt I'd been to not just to have Michael but also the stepsons and to have such a close relationship with my sister's children who were there. They are my nieces but I see them as stepdaughters.

Gabriel e-mailed me after that to say that my speech had meant a lot to him so I was very touched but I was saying it from the heart, quite genuinely. I feel I've been enormously privileged. I would have liked more children, but that didn't work out

but feel I was given the chance to have other relationships with children, and I've been very lucky in that.

Esther

I've got one son, Peter and his dad is Gary who already had two boys Daniel and Mark; then I had a relationship with Henry for over five years who had a boy and a girl with somebody else so I was very involved with them. Now I am with John and he's got two daughters, one of whom does officially live with us, although she's at university now.

I was a stepmother when I was twenty three before I was a mother. I was very young. Now that I am older and all my stepchildren are older I realize just how young I was. Daniel was seven when I met him so the gap between us wasn't that big. That was the most difficult experience of step parenting. The rest of my step parenting has brought me a lot of joy, but that one was a bit tricky because of the way it started.

First Relationship

Before I had Peter I was dedicated to a spiritual teacher. I lived with a community in service to God and it was very simple.

I left school when I was fifteen and had to leave home as my father wouldn't speak to me because I dropped out. When I got into my spiritual teacher it was terrible for my parents because they are intellectuals. If I could have thought of something to do that would have annoyed or freaked them out the most that would be joining a cult, which was how they saw it. It was most difficult with my Dad. My Mum was rather like all Mums; more concerned to see that her children are happy. Certainly, she was much more upset about me going away and whenever I'd come home she would be upset about the fact that I had left home so early.

I got some surrogate parenting from living in the community home. I had my teacher as a father figure in my life, who, even though he wasn't around me gave me more of a feeling of love and protection than I ever got from my own father. I also got a lot of sisterly stuff. I was always the baby of the house and so the community was like a surrogate family. The aspirations I had during this time were the usual

hippy fantasy of going to live in the country and running my own smallholding. All that stuff. I never did.

I left to be with Gary because I met him when he was still married with these children and fell in love. It wasn't measured or thought out and of course the pregnancy wasn't planned either. I was one of those young people who doesn't plan anything anyway.

I felt so guilty that Gary had left his wife (Pauline) and his children (Daniel and Mark) to be with me and forever afterwards I feel I would never do that again. At the time I was very young and had no idea what it was to have a family. I felt that I had no rights in the situation even when I was pregnant. Even during my pregnancy I felt that they were the priority and were the most important.

Gary and my living circumstances weren't great so he would go over to their house a lot or we'd go over the two of us. His relationship with his ex-partner fluctuated so there were times when it was good and she would want him and me there a lot. At those times she was fine with me being there and then there were other times when she didn't want to see me. Gary would baby-sit three times a week and he'd be on call. He carried on being the husband and dad really in the sense that if something broke he'd go there.

Talking about this makes me want to cry, it's bringing up things that I never thought I would be tearful about anymore. It's the pregnancy and Peter, I didn't feel it was a very good start. The Christmas when I was pregnant with him, Gary went to his parents with his family and his parents didn't know about me. He still hadn't talked to them about me, let alone that we were expecting a baby. It was really hard.

One thing that made it hard for me to sort my own feelings of being neglected and being sorry for myself was that other people were asking questions such as "What was I doing seven months pregnant on my own or going back to my parents at Christmas?" I was already asking myself "Does he really love me? He's going there, they are the priority" so they were voicing my doubt from the outside. I felt I could

not admit it and had to justify and explain what he was doing to them so I couldn't be in touch with how I felt.

Becoming a Mother

There's many simultaneous stories in this you know. There is a story of a very lonely parent who feels they are on their own, but then with other women she was very supported.

When I had Peter and I remember these first glorious two weeks when he was born where I felt I had Gary to myself because we had this little being. But after those two weeks I felt alone a lot of the time with my mothering because Gary worked very long hours. He was doing building and would be out of the house for ten or eleven hours, and we had the boys at every weekend. With Peter being so tiny, the boys would go off and do things that didn't include him because he was too little; they'd go swimming on a Saturday morning so the early years were quite hard.

I didn't have much sense with Gary of sharing the parenting, but my saving grace was having a group of women where we were all having babies at the same time. There were three women who lived in the village had kids at the same time. Further out there were other women, and we were part of a big community of alternative types. The bond that we felt was of being women all with a certain outlook on life and similar priorities. We all had a very similar child centred parenting style. The men didn't figure so much because they were at work.

I adored Peter. He's always been my little boy, but I think that if I hadn't had the support of other women I don't know how it would have been. I can remember when he was two or three and just sort of sitting there and staring. It's a love affair. It's a total love affair. You just watch him and everything he does is wonderful. I felt like that from the start although I am not so great with babies and can't remember much about when he was really little.

It's been very hard since Peter started to leave home. It's been very hard, because actually being a mum has been the best experience of my life. I am sad because I am grieving about him not being here. The choices I have made in life have always

been centred around Peter. My decisions in terms of what I did for work were always whatever fitted best with being a mum. I found work that I could do at home and could be there for Peter; it was very convenient. It's not that I was just a mum, but really that was my main identity. I realise now, not all women do that and probably that makes a big difference to how you feel when your children leave home.

John was asking me the other day "Did you feel fulfilled as a mother?" Because, he was a single parent and it was never enough for him; he really needed to find his mission in life. I know that I struggled being a mum, it wasn't always easy but being Peter's mum as been my biggest joy; it's been great. I think I was one of the typical young mums where actually being a mum is incredibly convenient because it means you don't have to think about what it is that you really want or what it is that might fulfil you as a woman you just go completely into being a mum. "this is what I am and this is what I do" it makes life very simple in many ways.

Nevertheless I did my degree from when Peter was four to eight and then went straight on to doing a PhD which I was in the process of doing when Gary left. So it is kind of not true that I was 'just' a mum, but that being a mum was really my main identity. I applied to do a PhD partly because the grant I was potentially going to be awarded from the Economic and Social Research Council was more than I would get as a salary for any job that would have been available to me at the time. There did not seem to be a job that appealed to me locally anyway. I never thought I would end up as an academic.

First Stepfamily

I remember a whole period of time when it was great having Daniel and Mark because they were like brothers for Peter, and I wanted that for him. I had an abortion when Peter was two or three. I remember feeling that I didn't want to go through another pregnancy as lonely as my first one. I didn't feel that Gary had the time or energy to be there for me in the way that I wanted. I have never been very robust so, I was exhausted just having one child. I didn't drive and we lived in this place that was stuck out in the middle of nowhere, so, it was quite tough and I did

feel isolated. I did have friends around the village but unfortunately I lived outside the village and it was a one and a half miles to get there.

An interesting aspect of having Daniel and Mark around was that it really mattered to me that Gary was a good dad. At the time I convinced myself that he was a good dad but in retrospect I realise a lot of it was my huge desire for him to be that. One thing was that he was hopeless at communicating and so I was the one who would communicate with Pauline. If she had concerns about the boys then she would talk to me and I would kind of bring it up with Gary or try to do something about it.

Daniel was always a bit problematic and he was very resentful of me. I remember from early on was being aware of that and really struggling to accept and understand the way he felt and not take it personally. That was hard; but, he grew out of it, though he was always the one who really needed Gary's attention.

When I was very young I felt competitive for Gary's attention. I remember I was in a self-help therapy group at the time and we set up this role play where one person was Gary, one person was Peter and another Pauline. In this drama everybody was trying to grab at Gary and I just walked away. And that's what I did in life, I didn't fight for Gary's attention. I just gave up very early on.

I'm not good at asking for attentions. It relates to my family of origin where I was a neglected child. I gave up very early on in regard to getting attention from my parents. I have my own explanation of it, because I have done personal therapy as well. I was not planned and my parents were struggling immigrants. They had only been here three years. My Dad was studying and my mum worked until the day she had me and went back to work when I was two months old so I was in a nursery at two months.

As the boys got older they needed more of Gary's attention and I began to feel that perhaps he wasn't the great father I had hoped he was. He expected Daniel and Mark to come to us where we had a room for all three boys, and hang about as if it was their home; but it wasn't their home. I wanted Gary to make more effort to go to them and make plans with them in Norwich, or do things with them one on one. I

know Daniel would have loved to have done things with Gary Daniel was definitely a child, who wanted to be the most important one. He was the first born and did get a lot of intense attention from Gary to start with. Mark who was used to playing second fiddle probably wouldn't have wanted it too much because he was never used to it. Empathetically I can relate more to Mark not wanting to be in the limelight than to Daniel.

Of course as their social life developed they didn't come out so often because they had stuff going on in Norwich. As they grew older I grew to love them and also feel very proud of them. I would have conversations with Pauline that I am sure she wanted to have with Gary because you want to have them with someone. Of course, ironically I was not able to have those conversations either because Gary left when Peter was ten. So all those years when I wanted to share achievements or talk things over he wasn't around. I do have a very good friend who was there for me, but it's not quite the same as with the father of your child.

Separation

I became a single parent when Peter was ten and I had to provide for him. Gary left and went into a family where there were two boys and then they had another child and started a new family. He stayed in touch with Peter but I felt exactly the same thing as I had with Daniel, which was that Peter was expected to go there and fit in with this other family.

Peter was desperate for Gary to do things with him and he articulated it as well. But when he spoke to Gary he got so much flack. That got to me, made me so furious! Gary would get so upset; he would say to Peter "How do you think the others feel? You can't just ignore the others!" It was just stupid. I guess my perspective is slightly jaundiced because I was rejected but I just felt like shoving their heads against a wall because it just seemed to me such basic stuff. You didn't have to be a psychologist to understand what Peter needed, who was the one who was having to make the most adaptation. There needed to be some give from Gary towards Peter.

My sense was that Gary and his new partner were busy creating their new family and taking time out to spend a bit of time with Peter didn't fit with that. They wanted

Peter to be a seamless part of their happy family. Whereas, I knew that Peter felt a bit lost and unconfident among all those boys. Of course, that was very painful for me to see that and not to be able to facilitate it in some way. Peter struggles with his self confidence and self esteem to this day. He's had a difficult relationship with his Dad and doesn't feel his Dad likes him. It's similar to how it was with Daniel and Mark.

Daniel and Mark were furious when Gary left me and their loyalty must have been all over the place. They were saying that they didn't want anything to do with him. It must have brought up a lot of stuff for them from their own past as well as seeing it repeated in my relationship with Gary. At the time he left they were teenagers around sixteen. They were already leaning toward being independent and I was seeing a lot less of them by then. They were getting older and I saw less of them but they were still there.

I feel sad about losing my stepchildren Daniel and Mark as well because I was a witness to a big chunk of their growing up and their childhood. These children that you've grown to love become part of you; it's an awful thing that you then lose them. They moved away and went to university. Daniel got married a few years ago and I wasn't invited. I have met his wife because there is this community here. Every time he comes back here Peter says, "Oh you must come over" and they always say yes they will but they never have. I know how that is. It's just that they are getting on with their lives and because of what's happened there is no facilitation of us to see each other for example at those family occasions where you would see the young people that have grown up. Because they're not my own children I don't feel involved in their lives. I don't feel banished from their lives and their world but there's not really any opportunity to see them. I had a lovely chat with Mark not that long ago, but I know we'll probably never sit down and talk about their childhood I have occasionally bumped into them both and it's lovely to see them.

Single Parenthood

When Gary left I became a single parent and Peter and I were a family unit. I was with somebody briefly and there was a situation which was like these conflicts you

hear about in families between the son and stepfather. I realised I would never allow myself to be torn. There was just no contest. Peter was my world and if there was any hint of being made to choose or that it was causing too much conflict for Peter the man would just be out.

I felt when Gary left that Peter was very unprotected in that he was totally dependent on me and probably wasn't as rebellious as he probably needed to be and might have been if he'd had other resources there to turn to. He and I had a very intense relationship and were very dependent emotionally on each other. I think early on it was more about Peter being dependent on me emotionally for my approval and love, and then as he grew older there was also the sense of him feeling responsible for me and not wanting to upset me.

So Peter was inevitably the man in the house, and he was a very incredibly capable, sort of practical person, which I am not. He's got that from his dad. So he would be the one who dealt with mending things, changing the gas bottles, and sorting things out. I think one of them – the house was symbolic because this bloody house that Gary and I built remained partly Gary's and I didn't buy him out until very recently. There was a lot of animosity between us and poor old Peter was very much in the middle, In retrospect I think that was what was going on was that Gary must have said that I was neglecting the house and I wasn't doing proper repairs on it, because Gary he was very bitter that he had invested so much in it. He [Peter] did tell me at some point that he felt very responsible for the house and that would have been for Gary as well.

When Gary left he wrote to me to say "I have allowed you to stay in my house," but there is no way he could have chucked us out, you know? He never tested that but in his reality he was allowing me to have Peter and stay there, which I knew was complete bollocks. In a way I would have liked him to have gone to court but there was no way he would have been given custody of Peter. He walks out and into this other family and then thinks he's allowing me to have Peter?!!

Second stepfamily

About a year and a half after Gary left I met Henry and acquired Molly and George. Henry was co-parenting but he had a very up and down lifestyle and we had an off and on relationship. Henry and his ex-wife's relationship was much better than Gary and Pauline's, it was like they were a generation on. They were more emotionally literate and had been able to consciously talk about what they were doing, what would be best for the children and how they wanted to co-parent. They were much more aware of what the issues would be and what the difficulties were. They had sorted a lot out by the time I came on the scene.

Henry had a daughter, which was lovely for me. It was interesting because his relationship with her started to touch on my issues with my own father. I loved the way Henry was as a dad in some ways and in other ways I felt very protective toward Molly because I felt that Henry found it easier to be empathetic with George. He was much more protective towards George than towards Molly. Of course I don't know, how much my view is filtered through my own sensitivities. Henry was very laid back and had this great thing where he would say – if they complained “I'm bored!” he would say ”and are you enjoying being bored?” He had done co-counselling and stuff like that so he had some good ways with them.

Henry didn't have a proper home so when he had the children they would come to my home. That made me feel very much like a stepparent because then I would want them to feel at home. I do love nurturing so I would be really pleased that they were coming over and do all the kind of nurtury motherly things with them like getting their rooms all cozy, planning the day, getting the food in and making us food.

There was quite an age gap between George, Molly and Peter who was a young teenager at the time and off doing things with his mates. He was also spending weekends with his dad, so the times when all five of us were there didn't happen that often. I always loved it when he was there and probably wanted him to be more involved than he was but he was never very interested. He had his weekend family that he was fitting in with.

Henry was a stepdad in the same way that I was a stepmother so Peter never had to really deal with a stepdad in the sort of authority sense. He was around over five very important years in terms of Peter's development, but in a very erratic way. What was great about him was that he would encourage Peter and side with him against me, so he was like a buffer for him. He was also very playful and would make light of it when there was a clash, so he somehow diffused the intensity and I think took some of the responsibility off of Peter. I guess that one day maybe Peter will talk about those years, but it felt great to me because it enabled Peter to be pissed off with me.

But Henry also used to exasperate me. The children were living in London so it was getting a bit more difficult to co-parent and it seemed to me that he spent so much time agonizing and being upset about the fact that he wasn't with his children more, it used to drive me bonkers! They would come to spend the weekend with us my home and he'd be sitting in the kitchen kind of agonizing over where his life was going and how his life was all fucked up because he wasn't with his children and his children were there. Again I was critical and had the feeling that the men in my life were not as nurturing as I wanted them to be.

But I loved having George and Molly especially Molly. I still see them even though Henry and I split up after five years because they both live locally. I feel a connection with them – a bit like an Auntie - in the same way as I feel towards other children who I've known as they grow up. It's slightly different with George and Molly because I step mothered them.

Relationship with Peter

Gary and my relationship wasn't great for many, many years and it's hard for me to remember how we were together as a family. I only hear what other people said, like "Gary was a bit of a bully" I was probably compensating by being the sort of softy and protective one. The thing that I remember loving the best about us as a family was Peter coming into bed with me and Gary in the morning with him being between us. That's my image of sharing and the family. I have lots of very bad memories, but that is a happy memory. Peter used to do that with Henry as well

once Henry had been around for a bit, and he carried on doing that until he was quite old really. He was still sort of coming into bed with us when he was fourteen. You know, I loved that. It's awful to say, but I loved it when Peter was ill because he would be sitting still and being all cuddled up on the sofa and I would look after him. Then as he got older the only times I've been in that situation is when he's been heartbroken and had a break up with a girl, which has always been awful and poignant.

When I think about it Peter is the only one of the children that I feel close to he's the only one who's this side of the loneliness. Everyone else is slightly removed.

You know, being a mother is like one long experience of loss. I can remember being on the beach with Henry when Peter was only fourteen and crying and bawling my eyes out about how I was losing him. The minute they are born they gain their independence and you are losing them; that's how it feels for me. But when Peter left for university was the biggest one, cause he wasn't in my house anymore. I remember he was only at university then for four months but I was crying whenever I saw a mother and son on the telly; I'd cry, whenever I would look through his bedroom. Then he came back four months later!

Third Stepfamily

There is a kind of progression in my relationships with men from Gary who was a very traditional emotionally closed father, to Henry who has much more a sense of co-parenting, to John who I met in 2000 and really was a co-parent. John was not only a co-parent but was the one that worked part time, got the family benefits, dealt with all the educational stuff, and lived literally fifty-fifty with Lily. John and Lily's mum Sharon lived round the corner from each other and they'd always co-parented.

When I met Lily she was fourteen and Sharon and John had never lived together. They'd had Lily in a housing co-op and split up very soon after she was born, so, they had always co-parented and done this fairly OK job of it and for example always took her out for her birthday together. Because John lived in ***** I managed to get some work at the University there and started living with them during the week. Peter by then was sixteen. I talked about it with him and he said

“Look mum you’ve always been there for me and you’ve always made decisions around my needs. Now you really need to go and do what you want to do.”

I didn’t necessarily want to go to ***** but it seemed that if I wanted to keep the relationship going that I needed to go there because Lily was there. At some point Lily decided to come and be with John full time when she was sixteen because then she could choose. It’s ironic because you hear parents talking and you might think it would be ideal to share a child half and half but of course Lily hated living in two places. She said it did her head in having two sets of everything and she never knew where she was going to be. So, when she was sixteen she said,

“I’ve had enough. I am coming to live with Dad.” and came to live with John full time.

So then here I was in yet another relationship with a family and that was really interesting. It stirred up a lot for me because as far as I could see Lily twisted John around her little finger and he was a totally devoted dad. I was jealous and irritated and felt she was just this little princess. But there was another side to things; John gets very stressy and stressed out and barks at you and has all kinds of ways that I found really upsetting and difficult and which Lily found upsetting and difficult as well. So it was an affirmation to have this other female around, and I am sure it was the same for her. We joined together against John and this great bond developed between us. We laughed together about John and defended each other and supported each other when we were hurt or when John was being annoying. Again, because she was a girl and because I had never had my own daughter, it was lovely to have Lily in my life.

Lily had a very difficult relationship with her mum who I don’t think is a very kind of nurturing mummy type person, so there was quite a lot of room for me to be nurturing. Although John is very involved and committed he’s not a woman so it felt like there was room for me to do what I liked to do. As she’s got older things have got better. She’s become much less self centred than she was; she’s much more mature and I’ve spent some lovely times with her. When she was younger and she talked non stop and was very exhausting and self centred; you couldn’t have a

conversation with her but you could listen to her, whereas now she's more of an adult, she's lovely.

I was living at John and Lily's house but in 2002 when Lily finished her A levels they moved in with us. For a year there were four of us living in the house. Lily wanted Peter to be a big brother and I wanted that too. He was sometimes willing. She would always remember his birthday, she would text him. Occasionally we'd all go out together for example for three years running at Christmas we went to see a film, and the four of us did have one Christmas Day together where we were like a happy family. It was quite brief really and, it wasn't easy for John, but that's his story of being a stepdad.

I guess that was the first time that somebody had really moved into mine and Peter's space and John always felt that it still was our space. It wasn't until we moved to this house which is mine and John's equally that he felt more able to start saying what he would and wouldn't accept from Peter. They had one kind of, confrontation - by then Peter was nineteen or twenty – ending up with Peter walking out of the house. I felt dreadful and panic-stricken that Peter would never come back. Even then I did not know if I could 'stand by my man' if it meant losing Peter. He did come back and apologise and John dealt with the situation brilliantly. But according to John there is always a slight nervousness between them which I chose to ignore, I guess because I want the 'happy stepfamily'

Last and not least, in terms of mothering is Leila. That's a real biggie, because John and John's ex-partner have a terrible relationship; it was a terrible splitting up and had dreadful consequences in regard to John trying to assert his rights to see his daughter. He took her to court and the whole thing has been dragging through the courts ever since I've known him.

When I first met John he was only seeing Leila for two hours a month in a family contact centre which was this dingy little place in ****. There was a period when they managed to get a mutual friend involved as a chaperone and I think John took Leila out a couple days to the park. Then something happened and everything blew up again.

Two years ago we were in court and I think Fatima or the judge suggested that I chaperone. To do that I had to see the psychiatrist and was asked whether I knew what I was taking on and how I felt about it and blah, blah, blah. So I started going to the contact centre to get to know Leila and to start to form a relationship with her. It was a long and painful process. Then we all started to see a family therapist in order to work towards having her out of the contact centre so there was a whole saga of me becoming involved in this situation. I had to meet with Fatima with the therapist and that was pretty awful.

We seem to have moved forward to the point where John and I are now taking Leila out for the whole day with me as the go-between, even though right at the beginning I said I wouldn't do that. I used to get all sorts of dreadful e-mails from Fatima and have to be neutral and courteous with her, but because she doesn't want to have any contact with John I am the one to e-mail her to talk about where are we picking her up go to pick Leila up and drop her off. So I have a weird role.

Aside from that I've got this new daughter in my life and she's lovely. It's weird because she reminds me of myself much more than any of the other children. I think there are lots of reasons for that, because she is an immigrant's daughter. They live in the same place as where I was born and her mum does similar work to me. Leila is like I was when I was little; very precocious and articulate and she loves writing. She's much more of a performer than me and she does stand-up comedy routines. I just think she's a fabulous little girl.

A year ago it was unthinkable that we might take Leila out for the day and now that's happening so I am fantasizing about her coming to stay. Nowadays we pick her up at eleven, take her back at six and Fatima seems much more relaxed. We occasionally have had the sort of e-mails like I used to have with Pauline, where she tells me things about Leila. I think I have missed being able to talk about a child with the other parent and taking pleasure in them together. Saying, "You know what she said?" that kind of thing. I still feel that need hasn't been fulfilled. I don't seem to have those kinds of little exchanges with John about Leila. Maybe we have different communicative styles. With John it's been fraught with trauma and is still

tentative and he has so much resentment and anger towards Fatima that it's not a light thing. When we go to see Leila he's always totally emotionally wasted afterwards. It's not easy for Leila either. It's clear that it's hard for her to make the transition from her mother to us and then back. Sometimes she's a bit withdrawn and quite tired and John is often very tired.

Sometimes with Lily I almost feel like I am intruding cause John can get very jealous about my relationship with her, whereas I would love John and Peter to have a good relationship. For example I bought Lily Christmas presents and he said "you don't give her Christmas presents, I give her Christmas presents!" I'm like, "No, I always give her Christmas presents." Or if Lily has told me something and she hasn't told him it's like "Oh she talks more to you than she does to me!" So, there is quite a lot of jealousy rather than him being really pleased that we get on. It's sort of bizarre.

So I've had stepchildren all my life and it's been fine to talk about them. But talking about Peter brings the tears up. I think there is so much hurt there about my relationship with Peter's dad and I do panic sometimes. I've had two abortions and I sometimes think, "What did I do? I've only got one child".

I remember coming home on the train once and chatting to this bloke and I must have said I've got a son, and he said, "Oh, you must have more children then if something happens to him ...". It seems to be a weird reason to have more children.

Of course it means that a lot hinges on Peter. I suppose even though I have done my best I am sure I have put a lot of pressure on him to be with me rather than his dad. I know that Gary hasn't been the greatest dad, but I also know that I wanted Peter to be loyal to me. If he'd had a fantastic relationship with his dad I probably would have been really jealous.

When I thought about this interview I had the idea that I'd like to tell somebody the story of my stepchildren. So, that's what I focused on really rather than on my mothering as such. But I would say that mothering was the making of me really.

Leanne***First Family***

I originally came here from Wales with Andrew who's a Welshman, and we lived there for seven years. We got married when I was pregnant with Dan. Later I had David, and then Andrew legged it with Linda a sixteen year old. It was a bolt from the blue at the time for me and Linda's mother although with hindsight I might have seen it coming. I was then on my own.

It's hard bringing up kids on your own, but I can't help feeling it's even harder to bring up two kids and a grown-up child like Andrew was. He was idle and self-indulgent and he'd been a drain financially and emotionally.

Andrew would have these schemes. When I was with Andrew our way of getting by was to be on the dole. We'd hit a patch where there weren't any bills due and so there'd be a bit of money that week. Then he'd get some scheme. "Oh if only I had a really good tape recorder then I could tape lots of musicians and charge them for making these tapes for them, set up my own sound studio and that would solve all our financial problems". So he'd buy this incredibly expensive piece of equipment and play with it for three months. Nothing would come of the financial gains that he envisaged and in the end there'd be the rest of the hire purchase debt to pay off, but he'd have already sold it to somebody because the next scheme was to get a Land-rover. "If we had a Land-rover we could cart fire wood around for people and make a lot of money doing that" - another scheme! So we never got ahead of ourselves at all.

In that relationship I was the one that took responsibility. I was the one that filtered money away out of Andrew's grasp without him noticing so that I could pay the electricity bill. Once he'd gone and I'd paid off all the debts that he left us, I was much better off. It was easier to make my own decisions on what the money was going to be spent on, and how things were going to work; it was a lot easier.

When Andrew left me he did a moonlight. He said he was going off to South Wales to see his mates, get a bit of head space, sort things out in his mind, and then he'd be back. He disappeared with the car. Then after three or four days, when I was starting to think

“I haven't heard from him, where's he gone? he'll probably be here tomorrow or something”

I had a phone call from Linda's mother who asked “when are Linda and Andrew getting back from Wales?”

I said “Linda and Andrew? This is the first I've heard of this”

she said “Oh didn't you know Linda was going with him?”

“No I didn't”.

“Oh”. It occurred to me “hang on a minute Gloria”

I went off to the drawer where the cheque book was kept, opened it and it was gone. I instantly knew what had happened; he'd done a moonlight. I realised that Gloria was almost hysterical at the end of this phone.

Now I'm quite good at coping with things that you can't do anything about. I tend to straighten up and go, “oh right, what's the best thing to do here?” and that's what I did as soon as I realised what had happened. So during the first few minutes of discovering that my children's father had gone off with a sixteen year old, I was comforting the sixteen year old's mother, saying

“Come on Gloria, you know, they'll probably be alright” and this sort of stuff.

It was the boys that held me together in that situation. If I hadn't had children to look after I'm sure I'd have been a lot more self-indulgent and got into the screaming and the howling and the, “oh god woe is me, I've been done wrong”. But because the boys were there I just had to phone up the dole, change the name on the car insurance and sort things out.

Contact with Father

It was difficult with Linda especially in the first year when I felt very resentful and hated her and I named my sheep after her. However about a year after when and Andrew had been living near us and I was on my own with the boys, I went over to see my friend Marianna who was like a go-between between me and Linda.

Marianna said “you know Les, you ought to be grateful that Linda’s taken Andrew away from you because if she hadn’t he might still be there”. It was like a revelation, “Oh yes, oh my god...of course, I’d still be under his yolk”. It completely transformed my attitude having this pointed out to me.

David was six months’ old and when Andrew left and I don’t think he was very aware of him at all. Andrew went away for a year and when he came back he got a house with Linda over the west of the county, and was able to have the boys for the odd weekend. He wasn’t very good at that and I had to do all the travelling. It was basically down to me to get the boys to see their father. He did things like promise he’d take them out to a firework display and then not turn up so I’d be left holding the boys disappointment and it used to drive me barmy. Then he moved into the village up the road here. He went to the top of the council list because he wanted to be near his children, and said he needed a three bedroom place because he was going to have them up there. So he and his girlfriend moved in and he only came to see them half a dozen times in all the years that they lived down the road. The boys had to make all the running then; I didn’t have to take them but they had to go round there because sure as hell their dad wasn’t gonna come round here. In fact I had a conversation with Dan not long ago, about how cheated, (no that’s too strong a word) how disgruntled they felt that they always had to do the contact making and that Andrew didn’t make any effort to display to them that he wanted to see them at all.

I lived in the house on my own with the boys for three and a half years and then I met Phil and we fell in love. He had recently split with his girlfriend, the mother of Jack and had some time before split up with Marge the mother of his son Ben. Phil came to live in the house next door with me and we’ve been in this spot ever since. We moved to this house next door because this building plot became available by

that time we'd bought that house, and the mortgage wasn't quite as hard to pay as before. This one came up as a building plot so we bought it as well and built this house on it.

One winter we all went to Portugal for six weeks because Phil and I had a job out there. I got permission from the school and made them write a diary every day, sort of quasi school work and stuff and we all went off to Portugal for six weeks and that was fine. The following year we had to go out there again over the winter, and the boys decided they didn't want to go to Portugal and asked if they could stay with their dad. I went to see him and he said "Oh yeah sure, leave them here, they'll be fine" so they stayed there for six weeks. We had somebody in the house here, looking after the animals and all the rest of the stuff. When we got back we found out from the house sitters that the boys hadn't actually spent a lot of time round at Andrew's. They'd gone round there to be fed from time to time but they came back to the house to watch the telly and sleep most of the time even though they had beds up there. So they spent a lot more time down here than they did with their dad.

Andrew died a couple of years ago, out of the blue. That was a bit difficult. Dan and I were just going off to work. We were out the front here, getting in the van ready to go and I saw my next door neighbour. He shouted over the hedge, there's an ambulance outside Andrew's. So I thought we better go round there and see what's happened. We drove round there and sure enough things looked pretty bad. So I thought, "well what do I do? I'm the ex-wife. This looks like Dan's department". So I said to him "you go up the path" – it was a very long front garden – "you go up the path and see what's happening. I'll stay here and if you want me, come down and call, and see how things are. See if Linda does or doesn't want me there but you've gotta go and suss it out".

He went up the path and while he was there the paramedics told Linda, who by now was his wife, that he was dead. Poor lad! So, he came back down and I went up there myself. It was all hugs and stuff but Linda was shocked, and asked me if I'd go and get Celia her friend. I left Dan comforting his stepmother, while I routed Celia out of her job which was quite difficult because she works with people and was

in with a client. However eventually Celia came out and saved the day. But it was an ambiguous situation to be in. I didn't know whether I was needed or whether I was making things worse.

Stepfamily Life

When Phil and I got together it was a bit fraught. Fortunately all the boys seemed to get on fine together. It would have been absolutely appalling if they hadn't got on well. If anyone was going to clash then it would be the older ones together or the younger ones.

As a mother I did all the practical things such as peeling twice as many potatoes. Jack was also quite a picky eater as well so that started off being a problem until I sussed that he would always eat potatoes, so taking the least line of resistance I'd make sure that whatever I'd cook for everybody else there was always was a huge pan of potatoes. He was then happy with whatever else or he'd have potatoes with a bit of grated cheese on. Overall I took things in my stride although sometimes it drove me barmy and things got to screaming pitch. On those occasions because Phil was there I had an out. I could say 'right I'm off to the pub' jump in the car and drive off with my fags and a couple of quid in my pocket. If all the children had been mine I would have felt, 'oh they're my responsibility, I've got to see it through', but because half were Phil's I could actually drop everything and run away. I guess that gave the boys a bit of a turn from time to time. They had this woman suddenly say, "right I can't take any more of this, I'm off" and marching out.

Ben had had a really hard time. His mum had formed a relationship with Jules, his stepfather, and she'd had two more children with him. Jules and Marge had separate houses but Marge was spending a lot of time in Jules's house with the two young children and Ben seemed to be left in Marge's house a lot of the time. Ben got on really well with his half brother and sister because he's good with little children but whenever Phil and I went round there he seemed to be there by himself while Marge was at the other end of the village with the new boyfriend and the two babies. Ben always seemed a bit down in the mouth but would never admit what was going on with him, so it was never very clear whether it was his choice to stay behind by

himself in the house because things were too uncomfortable for him to join the rest of the family or whether he was forced to stay behind. He did used to go up there for Sunday dinner and stuff like that but that was it.

I got on well with Ben and felt very sorry for him because he was obviously not happy. I couldn't really understand why he didn't come to us earlier than he did, but he was at school over in that direction so there were practical considerations as to why he should stay over there and I didn't want to get between Phil and Marge who had made the arrangements. He'd come over to us roughly every other weekend but poor little lad he was so miserable. We had Jack every other weekend as well. Sometimes it coincided that we had all four of the boys together, and sometimes it would be three. Things were a lot more equal with Phil than with Andrew. I guess having two children each in the setup reinforced that equality.

Ben came to live with us when he was sixteen. He gravitated towards me and Phil, rather than towards his mother and stepfather because it was more difficult for him to be included with them. Once he'd moved in with us properly he didn't see his mum that often. He'd see her round his birthday and round Christmas. He'd go over there to get his divvy up with the presents. He came to us as a very traumatised 16 year old with braces on his teeth which had just been tightened up by the dentist the day he moved in with us. Poor lad, I felt so sorry for him, he was so miserable. He'd got a place at ***** College because his mother lived over towards the west of the county and he was more orientated in that direction. He'd got himself on to an art and design computer course over there and had digs in town so initially when he moved in with us he was only here for weekends and holidays, and spent the week there. Then he left college, applied for further education, and got a place in west Wales, so again he was only around for holiday times. When he finished college he moved in with us full-time and started working with Phil almost immediately, so he became a permanent resident then.

Both Phil's boys, were reasonable sort of guys although Jack could be a bit of a problem sometimes. He always had a lot of self-confidence and would come over as a bit pushy, but that was just his manner. I suppose that was what caused the friction

between him and David because Jack'd be slightly aloof, which used to drive David mad. David had a very thin skin, you could wind him up no trouble at all. He was just one of those kids. Dan and Jack both got at him, but Ben was more sympathetic and didn't do that in the main, although sometimes he couldn't resist it either. I guess if it came to the crunch I had more sympathy with my children than Phil's children, but I'd sympathise with Ben and Jack if that was the way things were going. If we were out anywhere with kids that were more distant from the four of them, then I would take Phil's kids instantly into the family fold. At such times they were more my kids than other kids were, so my family expanded according to the amount of outside opposition they got.

Phil was available for his sons on a practical level. Phil's good with babies and with young children and he's not so good when they start getting hormonal. He can be very jealous. I can remember him putting on his parts when the boys were getting older. He'd notice if I was favouring the boys over him for example if I'd shared out the last of the cake between the boys and not left a slice for him. He'd feel that he was earning the money and they get all the cake. There didn't seem to be any differentiation of who of the boys had got the cake, he just wanted to make sure that he got a bit as well.

Eventually Dan moved out and went to live with his mates. They'd got a house at a farm about a mile and a half away. I had to drive past his house to pick him up for work everyday. They were quite happy over there but they all got chucked out because the agents' inspector turned up. The boys had got it wrong, they thought she was coming the next day so they hadn't done a clean-up and it was an absolute tip. As a result they got their marching orders and all of a sudden there were five homeless boys a mile and a half away. Phil and I moved in here so that the five homeless boys could move in next door even though it was unfinished and there were no light switches on the wall yet. Our other house became the boys' house. (You can imagine what that was like). There was a sort of moveable population there made of a basic core of good friends. They'd come and go and sometimes there'd be some girls over there as well. The standard of the house-keeping would

go up incrementally depending on how many girls were living in there at the time, but mostly it was pretty disgusting.

So we were over here and all the boys were in there next door. Anna, Dan's girlfriend, sometimes stayed over there but she never lived there. Also Yvonne, who is Ben's girlfriend, moved in more or less, but it was hard work for any girl moving in with those boys, it was just awful. I mean the bathroom! God! Then Dan and Anna announced that they were pregnant and two months later Ben and Yvonne announced that they were also pregnant. About two months before Yvonne and Ben's baby was born, they moved out to Yvonne's father's house. He'd given them the top floor of his house and they intended to have the baby there with a midwife rather than going into hospital. That freed up a bit of room next door for Dan and Anna, but, Anna had a place in town still. Dan and Anna and some friends of theirs, also a couple, decided they'd move into town because Anna didn't want to be isolated in the country with a baby and no way of meeting her mates. That meant that we just had the lost boys next door.

When Yvonne was pregnant Ben and Yvonne had gone to France to see Yvonne's mother, who lives in France and has two houses there. (She sold one in England and was able to buy two in France for the price). They fell in love with a hovel which they brought with a car loan. So they made up their minds to move to France, but stayed with Yvonne's dad until a couple of months ago, before they moved.

Then the babies were born. Dan and Anna were sharing a rented house with Basti and Nicky, and Basti and Nicky were given the money to buy a house. So they left and Dan and Anna couldn't afford to pay the rent on a whole house. We were doing up half the house next door in order that they should come to live back here, but they left their house in town a lot sooner than we expected and had to move into two rooms which still had plaster not on the walls and stuff like that. They're still living in those rooms sharing the kitchen and bathroom with the lost boys, but it's more finished than it was then. We're planning on putting another kitchen and bathroom in the north end of the old house and splitting that part off so that Dan and Anna can have a family house. We'll keep the doors upstairs and downstairs so it can be a big

house if lots of people are living there and a small house if just the family are there without any hangers on.

Situation Now – Extended Stepfamily

Jack's always been close to us. But then his mum in contrast to Ben's mum has always been very much a mum to him. Jack's mum is a very competent mum; much more competent than me. She made sure that Jack went to cubs, got his canoeing certificate, learnt deaf and dumb language and all this other stuff that was totally admirable. I could never get that together I'm afraid. But she never found another partner after Phil, so I guess there's been some guilt on my part. I felt that if she didn't become part of our family then she would feel very bereft when Jack was over here with us and when he left, as he has now. Poor old Jan, she's quite a brusque woman, not the easiest to get on with but she's always been totally into doing the best for Jack and I've gone along with that, tried to make her welcome and include her. If something's happening like Phil's mum is coming to Sunday lunch then I'll pass out an invitation to her as well.

So we've included Jack's mum in the family, whereas I don't really know Ben's mother Marge at all. I've met her a dozen times I suppose. I don't know what happened with her and Phil, when they split up but the first time I met her she stepped back and gave out the message not to come to close, and its always been like that with her. Ben's stepfather has been more forthcoming but he's a businessman and I feel he's putting on his business associates smile when I meet him. He's quite jovial, but I feel it's a practice he's acquired through business to ask after the family and remember what your name is and stuff like that. But Marge has always been a bit of a mystery woman. She and her daughter are very horsy people they like their horses. I don't think I've met Ben's brother more than three times. Ben's wedding was the last time I met the family, altogether. And they were fine, but very distant.

Jack is in India at the moment. He and his girlfriend Lucy moved there a year ago to learn Indian and discovered that they could make quite a lot of money teaching English to the Indians so they're still there. They've just applied for an extension of

their visa to stay another six months. Lucy did international relations for her degree and I suspect they might stay there at least for the foreseeable future.

Jack and Lucy have just been back for three weeks from China after being out there for a year, and Jan took a holiday while they were back so that she could have the maximum amount of time with Jack while he was home. I don't know what Lucy feels about this but Jack was just the whole of her life and it's hard for her to have him in China. As I say I have a suspicion he might be over there for a bit longer.

Phil, I and Jan all went out there last spring. Jan found a cheap flight to Beijing so we couldn't pass it up really. She went out five days before we did because she wanted a bit of time with Jack on her own, which is fair enough and we all came back on the same plane on the way home.

It was great, because Jack and Lucy had got the hang of Chinese and taught us how to buy subway tickets and basic Chinese stuff. Jan was living in their flat, and Phil and I were in a hotel five minutes walk away. We were all together there for the first four or five days, and then Jack and Jan went off on a 2 ½ days train journey to see the terracotta warriors. It was great for Jan to be able to cart Jack off for a trek into the hinterland and have him all to herself for a few days. We were left with Lucy who was working, but we'd meet up and eat together in the evenings. I got to know Lucy a lot better for Jack not being there, because he's quite a strong character and Lucy is outwardly very shy so she doesn't get a word in edgeways with him. So that worked really well.

I said earlier that the balance in our family helped things and it did. But something strange did happen at one point, I felt like I wanted another baby to seal our relationship. I was hassling Phil from time to time about having another baby, and he'd always said "no no I don't want any kids, I've got enough kids. One time we were all out on the broads in a rowing boat, and Phil suddenly said, "oh alright we'll have a baby then" and instantly, It surprised me how fast, I thought, "my god nappies and all that sort of stuff again. Oh god I don't think I like this idea " I really didn't want one anymore I had just wanted him to say "Ok" as an admission from him that our relationship was long-term. It did make me laugh when I realised my

reaction to it. "Fuck, a baby. That's the last thing I want". It would have been nice to have a girl though.

I see Anna with her mum, and they have such a natural relationship. I'm originally from a very female orientated matriarchal society. There were four girls and one boy in my mum's family so it was almost the other way round to how I live now. My family kept pretty closely in touch, and we were always going off to visit one aunt or another, so we cousins always had a lot of contact with each other. The Barber girls would turn up and my dad would go, "oh bloody hell they're here again. I'm not gonna change my shirt for them".

"Oh come on Jack you must change your shirt".

"Well why should I change my shirt?"

They'd always turn up with a box of groceries, extra milk, just a girl thing really. You don't descend unannounced in somebody's household without bringing a box of stuff with you do you? I spent time with my aunts as well when I was growing up. I'd go and stay with Eve or somebody for a couple of weeks in the summer holidays. So it was quite a woman orientated childhood.

But since then there have been so many boys around me. I used to commiserate with the cat. "It's just us two against this lot". It's made me a lot less able to deal with the women in my life now. Even with the young people next door it's easier for me to talk to the boys than it is to talk to the girls. Smetimes I can't even recognise the girls because they dye their hair, put on a new face and stuff like that. I can be talking to a girl for 10 minutes and suddenly realise, "oh it's that other girl that was here three weeks ago, and she's wearing sunglasses and she's dyed her hair. Oh right".

But I get on with my daughter's in law fine. I'm so pleased the boys have chosen girls that I get on with. I mean can you imagine having them bringing women home and eugh, you know. If you hated the mothers you wouldn't be able to have any sort of relationship with your grandchildren would you? It'd be awful. So I'm very lucky. I've got a good big family and it's pretty harmonious. It's absolutely vast.

It's incredible. From only giving birth to two, I find myself in a large extended family. It's quite a surprise.

How things are now is that Ben is e-mailing us because he wants pictures of us lot to put on the walls, so his daughter who's two months younger than Rose won't forget what we look like. He obviously feels a family bond as well. It's amazing all these mother-in-laws all over the place. He's got a lot closer to his mum and family since the babies arrived. Yvonne is quite family orientated and I think she's encouraged him to make more contact with her than he used to. She comes from a family where they do have a lot of contact.

Ben and Yvonne's wedding was amazing because mother-in-law Marge was there, and mother in law Sue, Yvonne's mum was there, and there was me and Yvonne's father's girlfriend as well. So there were four mother-in-laws at the wedding. It was great all good fun.

There's a woman May lives over the back here who's got three boys, and she's always been incredibly hospitable to young people. There was a time when it was so hospitable over there, that I felt my boys had left home. I was really quite resentful of May, because they'd much rather be round there than they would come home. There's Portuguese blood in them and when they were 17 one of her boys James was going to go to Portugal to see his grandparents and invited Ben to go with him. Ben wanted to go. I had a stash of money that I'd put aside towards higher education when Phil and I started making a bit of money but Ben had given up his A-levels, so I knew he wasn't gonna need it for university. Instead I gave the money to him for a ticket to Portugal, and a bit extra. The idea was that they were going to get a job out there and work their way round.

They left, and it wasn't until half way through the time they were gone that I found out that they had both run out of money and May had lent them a whole load of money which they took because it was easier than getting a job. I was really pissed off that she hadn't let them starve until they'd had to go out and get a job, she'd just given them this way of dossing their way through Portugal. It didn't seem the point to me. I thought they were going on this adventure and if they hit hard times they

should get themselves out of it; that's part of the adventure. However May being the soft-hearted mother she was just supplied money to them, This meant instead of having had an adventurous time, learning how to do things and getting jobs, they'd sat around, got stoned in people's houses and came back with this fucking debt. Oh fucking May she'd go completely over the top. When the kids were small she'd have one of the old fashioned sweet jars full of Bounty bars, and Mars bars, and every sweet you can imagine. The kids could go into the pantry and help themselves to however many whatevers they wanted out of the sweet jar. I mean who can compete with that for god's sake? And it just carried on through their early teens. I found some other mothers whose children spent a whole load of time over there as well, and found out that they felt the same as I did, which was quite a comfort to me. I thought I was suffering alone you know. She's a lovely woman, she's great but she just collects children. Now those kids are grown up and they're bringing their own children back to see her.

It was the same when my boys went to Andrew's on the rare occasions they did. They'd have this wonderful weekend, be given Mars bars, and it was me who had to be the strict person. I was the one that held it all together and moaned at them for kicking their shoes to pieces against a brick wall and stuff like that. I had to do all the unpopular parenting. I never had so much as a penny out of Andrew the bastard, because he was always so impecunious, he spent most of his life on the dole. If he did have money it was on the black so that the dole didn't know about it. I never had any maintenance off him or anything at all. The boys used to catch the school bus just up the road here. Andrew came down one day and he said he'd seen them waiting for the school bus and how untidy they were, and how their clothes weren't up to scratch, and what did I mean by sending them off to school in that sort of condition. Oh I had a field day that day, it was great. Yes, talk about tongue lashing; my god! Andrew realised as soon as I went off bang that he was completely out of order and you could see him backing off towards the door. He never moaned about the condition of their clothes again.

It's been interesting bringing it all together because you just get on with things as you're living through them, but, to look at it as in terms of the dynamics that hold

stepfamilies together or cause ructions definitely blood will out. I can't imagine being fonder of a stepchild than I am of my own blood children. But we've rubbed along alright.

With my own children the connection is almost physical; it's that bond that could never be different. But then when I think of Ben and Jack, I can't imagine them drifting away and my never seeing them again. It's beyond comprehension. Maybe it's because I've been through it and we've got to a stage where they're making lives for themselves and all the logistics and upheavals, the schooling and the adolescent angst and stuff is all behind us. I don't know whether it's different for people who are still going through that sort of stuff, perhaps they feel that these people their stepchildren could disappear and they'd never been seen again.

There was never any sign of Jan emigrating to Australia with Jack, but I suppose it was always on the cards that she might because he was her child more than he was Phil's. But I wouldn't say that Ben was more Marge's than Phil's and Ben became more ours, the longer he lived with us, especially when he stopped just coming here for weekends. When he started living here full-time he became one of the residents. We've got a house full of boys over there, or boys and girls and that's always felt like we have a bit of an extended family.

Oh Rose must have woken up. I can hear the hedge trimmer going again. The local farmer has told us we can put the hedge trimmings out on his fields. Its great, it really means that, you know, today's the day; I always need a kick up the arse to get these jobs done. Otherwise they drag on for weeks.

Mary

I met Jim when I was visiting my sister Janet and her husband Andrew. He was their mate and used to come round to their house. At the time I was living near Wigan with my parents and Howard my boyfriend. I used to come and stay with them and eventually decided that I wanted to move to London, so I did so. I split up with Howard who was still living with my parents. We were still friends. He stayed on with my parents for about six months. .

I met Jim, fancied him and was sort of egged on by my sister (laughs). I arranged meetings and invited him for tennis and stuff; we weren't really together. Then Howard came to stay for the weekend and I slept with him. We'd been together for 4 years and I'd never got pregnant so I didn't think about it.

Looking back it's quite bizarre really because we didn't talk about any of it very much. I wanted to move to London and give up my job and just did it really. He didn't object much, so when he came to stay it was as friends, it was fun. A few weeks after that me and Jim got together and started having a relationship, so when I found out I was pregnant we had been together about a month. I can remember feeling that I couldn't tell Jim about it because I knew it couldn't be his, we'd only been together for a month, and I knew I was more pregnant than that, I must have been a couple of months pregnant. I was scared, I didn't know what his reaction would be and I imagined he'd probably want us to split up. I remember that my sister and her husband Andrew went out to give me the space to tell him, I tried to work up the courage and eventually told him. His immediate thought was that it must have been his so then I also had to say, "well no it's not". So that was how that went.

He didn't want to split up; it's hard to remember really but we stayed together anyway. It was quite strange because all through the pregnancy I was worried that he was staying with me because I was pregnant, or that he would want to split up when I had the baby because it wasn't his. There were loads and loads of different things I was worried about.

I felt unsafe and I think Jim did as well. But when she – Grace - was born he immediately fell in love with her. It was like she was his baby from then on. He was there at the birth laughing his head off, it was very emotional. For me, at that moment all the doubt went. Jim and I have talked about it and he's always felt completely in love with her and that she is his. He doesn't think of her as not his child, she's the same as the others.

I've always thought that I did it all wrong and that I should have done it differently. I always wished I had told Grace that Jim wasn't her father right from the very beginning. As far as Grace was concerned Jim was her dad and that was it, so then to tell her that she also had this other dad seemed huge. I didn't know how she'd react, I didn't know how she'd feel and I always thought that if she'd have known right from the very beginning then it would have been part of her life whereas to tell her now was going to be a big shock. At the time we just got on with our lives really. It wasn't an issue then it was only as she got older it became like "she'd better know. We're not going to never tell her". And then it became this big thing, "we've got to tell her", It went on for quite a few years.

I've never wanted to make to make a big deal of it but the older she got the harder it became and I didn't tell her until she was 12. Leaving it till then 12 felt like a long time but also I think that was quite a good time because she did have some understanding. I still think that if she'd always known it would have been better.

So that was all quite difficult but how she took it was amazing really. I think I took her out for lunch or kept her off school to do it and I'd gone over in my mind many times what I was going to say. I can't quite remember what I did say, but I told her the story of me and Howard, how we were together for 4 years and then we split up, and he came to visit. I think because she was 12, I felt I could explain it a bit more I suppose and that she might understand more than she would have done. I didn't want to say "Jim's not your dad "because that's just not true so I told her "you've got a biological dad as well' and explained it was his sperm. She asked a few questions and one of the first things she said was, but Jim's my dad and I said "yeah of course he is; definitely".

I think probably Jim was scared of how she might react and was very relieved that she still thought of him as her dad. I guess he thought that she might want to go off.

Grace didn't want to meet Howard then, but after about a year or so she said that she would like to meet him, so we went up, stayed with my dad and tried to get in touch with him. He was working away, so we couldn't see him then and after that she's never wanted to. He's now got a family; he's got three kids and a wife. I still feel it would be good for her to meet him even though she says that she doesn't want to particularly. What she says is that it would be really weird, it would be like meeting a stranger, but I think that there's you know something there.

I've often wondered about why she hasn't wanted to see him. Maybe it's just the way Grace is or maybe it's something to do with Howard. I can't even describe what I mean by that. Grace doesn't like talking about emotional things. I think there are things that she feels or that go on with her that she doesn't tell me? I've always wondered if that was something to do with Howard. I am very aware of the fact that she has always had a picture up of Howard in her room somewhere always had pictures of him so she must have occasionally thought of him. I want her to be well in herself, and things to be ok. I think it would settle something for Grace if she were to meet him. She looks quite like Howard. There's lots of things about her that are like him and not Jim. Jim didn't really know him.

I did try and get in touch with Howard myself a couple of years ago just to talk to him. I spoke to his sister-in-law and she said she'd tell him and she came back and said he said "it's all water under the bridge, it's too late to speak to me". That felt weird after all this time. I don't care how Howard feels about me at all but it would feel really sad if he felt that he didn't want to speak with Grace, which I suppose is what he is saying, but I don't know for sure. Every now and again I think I'll write to him. I would be really upset if she ever did try and get in touch with him and he didn't want to see her and I'm sure she would be. I now think I should have always kept them in touch. It feels like that would have been the best thing to do, because then it wouldn't be an issue now.

Maybe I should just let her get on with it and get in touch with him herself if she wants to. But I can't quite let go of it, I feel like I need to speak to him, I should sort it out. I suppose. I don't know why I think I should sort it. Maybe it's not right, maybe it's irrelevant, but I think at some point she must need to see him, to meet him. It would be easier for me to know that she was able to if she decides to. Whatever she felt about him isn't really the relevant thing what's important is that she'd be able to meet him because she hasn't ever knowingly met him as her dad, as her biological dad. He saw her a few times when she was little and has never tried to see her since.

It does stir me up when I think about it, it is emotional. I find it quite hard to put things into words, to express this. I don't really talk to Jim much about it. I've talked to other people and to my sister about it. Different people have said different things but it all comes back down to me doesn't it? One friend said she really thinks it would be good for Grace and that it would mean something to her to know her father so again that makes me think I should do something about it. What do you think?

Katie's always known about this ever since Grace's known, but Ruby had no idea and only found out just a little while ago, I think because her understanding things is different anyway...it's never come up. Grace just mentioned it the other day. I can't remember exactly. I think Ruby was talking about somebody having another dad, and Grace might have said "yeah I've got another dad" and Ruby said "what? What do you mean?" Grace says, "I've got another dad" and something about being really only half sisters at which Ruby freaked out. "No you're not you're my sister". Grace talks about it quite freely and quite openly with people.

You think that what I've said might be helpful? I suppose it's different from your other interviews. It's good to talk about. I sometimes think about it but not as like a whole thing you know it's sort of quite nice to talk about it all.

Since the interview Mary told me that Grace's half sister got in touch with her and they've been in contact. She received a picture with all of that family including her father waving to her. Mary says that it is a relief and that she can let go of that now and let Grace and her father take over.

Robin

What you're talking about here is the whole of my adult life. I embarked on this when I was twenty one and I'm fifty two now. And my first husband became a parent at twenty two. So it's amazing really. My older daughter's almost twenty six now and I was her age when I had her. I look at her and she's just a baby. I have people saying to me "God you became a stepmother at twenty one!". But at the time I just did it. I didn't think.

By the time I had my first child I'd had five years of being in a step-parenting role. David is twenty years older than my youngest, so Andy became a father for the first time when he was twenty two and for the last time when he was forty three. When Amber was born in 1981 David and Richard were fifteen and thirteen. Then when Erica was born five years later they would have been twenty and eighteen.

My current partner Steven and I have been together since 1994 but got married in 1999, we don't have children, and he has no biological children. And my ex is now with Barbara and she has two children, Dan and Helen. Their father was a guy called Stuart who's now dead. So I have two stepsons from my first marriage and two daughters from my first marriage to whom my now husband is stepfather. I've also got step-grandchildren.

First Family/Stepfamily

I was very young when I met Andy. His children David and Richard were six and eight at the time, and he'd been separated from his first wife their mother, for about four years. At the point at which I met him he was looking after David and Richard full time because his first wife had gone off to India for a few months. Because of that I met the boys virtually immediately after I met him. It was very, very quick. They were always part of our relationship and I didn't particularly think about it. I'd not really had anything to do with children in any shape or form before because I'm an only child, I didn't have any younger brothers or sisters or any nieces or nephews, but they were nice kids, I got on with them.

Andy moved in with me a year after we met, and by then their mother was back from India. She was looking after them during the week and the kids would come to us at weekends and school holidays. That carried on up till when Richard the younger one was about eleven and elected to come and live with us full-time which he did until he was eighteen. It was fine because I was young and didn't even think of any of the problems or pitfalls. Maybe I would have been more cautious if I'd been a decade older I don't know.

Richard was a conventional little boy and he wanted all of those things that children want such as bedtime stories and cornflakes for breakfast. David was a much less conventional little boy, and perhaps also had more of a loyalty or more ambivalence around his mum. He might have felt that coming to live with us would have been disloyal to her, I don't know. He was also older. I mean he was old enough to remember his parents being together, whereas Richard can never remember his parents together. Funnily enough, I then mirrored that with my own children because Amber's old enough to remember Andy and I being together but Erica isn't. So that's a kind of interesting parallel dynamic because both the eldest children - David and Amber - had a difficult time; perhaps that there is something about that.

The tricky point came when I got pregnant. Richard (the younger one who was living with us) was fine with that and he was really excited. David, who was fifteen and didn't come to live with us, was having quite a tricky adolescence and he found me getting pregnant quite difficult. I think he maybe had harboured a fantasy his parents would get back together one day or whatever. He'd always been fine with me before, but when he hit thirteen he started to be a bit rejecting of me. Its not that he was really terrible; he was never abusive to me, just grunty, rude and a bit graceless. I remember him saying to his father once when we were on a holiday "why does she have to come everywhere with us", or something like that. But it wasn't consistently horrible behaviour. He was just being a teenage boy really.

So when I got pregnant he was already being a bit tricky and distant with me, he just became a bit more so. He hadn't been coming to stay with us as much anyway, because by then we lived in a house in Hackney and he was visiting less. I think that was possibly as much about getting his own life with friends as it was about me.

But he didn't come to stay with us throughout the whole of my pregnancy with Amber. His father used to go and visit him regularly in Leytonstone but I didn't see him for quite a long time. He started to visit again when Amber was a few months old.

That was most difficult I think for him and his father. I was preoccupied at the time with being pregnant and working full-time as a nurse doing shifts and things, which was bloody hard work, but it bothered me at some level. If I look back on it now twenty six years later, I don't remember it as dominating my life; it was upsetting but nothing more than that. It was worrying for Andy, but he was in contact with Dave regularly and I suppose we hoped Dave would come round to the idea, which he did. However I'm saying that with the benefit of hindsight rather than how it was at the time.

First Child

I think probably in common with a lot of women when they have their first child I just entered this bubble of totally being in love with my baby. She was such an easy baby a lot of my friends who had children at the same time couldn't believe it. She was one of these babies who slept through the night from birth and didn't cry and was just so easy to look after. So it was great. I'd given up work, I had this baby that was a dream baby who didn't cry and slept all the time and it was wonderful. Richard who was living with us was completely in love with her as well. He was thrilled to bits to have a baby sister and was just old enough so that when she was a few months old he could baby-sit if we went out. He was pretty hands on in looking after her. I'd wanted to have a child for two or three years before I had her anyway, partly because I'd been unwell and I had to have gynaecological surgery so I'd been told that I had to get on with having children if I wanted them. It was also because I'd had an enjoyable time step-parenting. If step-parenting had been a nightmare it's

interesting to speculate whether that would have put me off having my own children isn't it? I rather think it would have. So by the time Amber was born I'd wanted to have a child for a couple of years.

Its different being a stepparent to being a parent. I'd had the recreational aspects of parenting with the boys because we had had them at weekends and school holidays, although when Richard came to live with us I was doing all the sort of things like buying the school uniform and making the packed lunches. But because my training involved a lot of weekends and shift work, I didn't have the regular pattern of always being around in the evenings or at weekends. I think that they probably did as much with their father with me not around, as they did with me there.

If they had been my own children I wouldn't have done the training, I wouldn't have wanted to embark on three and a half years of back to back shift work and stuff.

Although I don't know whether the different level of commitment was just because David and Richard weren't my own; there was also something about their age. The level of commitment with a baby is twenty four hours a day, seven days a week.

Whereas by the time I met the boys they were already at school. They were away at school when they lived in Leytonstone with their mother. So in terms of hands on care it was different anyway. But I think it's probably a mixture of both.

When you've got your own child there's something about wanting to spend as much time with them as possible. Well that's how I felt when Amber was very small. So I was with Amber twenty four hours a day at least for the first year of her life, whereas with both the boys by the time I met their father they were both at school age. In fact, I took maternity leave when I was about seven months pregnant with Amber, and then didn't go back to hospital nursing and shift work at all until she was fourteen months old, and then I was very much part-time. Although I wanted to be with Amber all the time I might not have felt like that if she'd bawled her off or had colic. She was such an easy baby to look after that it didn't feel like hard work. When she was two and a half I went to university to do a health visiting diploma because I wanted regular hours, I wanted to work nine to five Monday to Friday, so that was the decision we made.

My next daughter was born five years later and she wasn't difficult but she didn't sleep through the night from birth. She woke up in the night for the first three or four months, but she was still pretty easy really. I was there full time for her until she was 8 months old and then I went back to work three days a week. By then I was working as a health visitor, I was living in Hackney, working in Tower Hamlets, and I used to drop her off at the child minder's on the way to work. So I wasn't at home for as long with her.

It must have been in Amber's first year when David took his O-levels, and he moved. He left London to go do his A levels at Sixth Form College in Scotland. We saw him when he came back in the school holidays. He was down in Scotland for two years and then he went to Manchester University to do art. I'm not close now to David at all. I see him very occasionally. He's quite a tricky person anyway, irrespective of my relationship with him as a stepmother. His brother finds him tricky, his father finds him tricky and he has lived abroad for a lot of his life. When he finished university he lived overseas for about fifteen years. He's only been back in this country quite recently.

David distanced himself, but I think he distanced himself from all kinds of things. He was living abroad from the age of twenty one until his late thirties. That was also because of his work. He's a conductor so he works all over the world conducting orchestras and studied abroad for a lot of that time. Richard in comparison carried on living with us and was on the brink of moving out when Erica was born. He continued to visit a lot and lived with us on and off for a combination of reasons. He didn't go away to university, although he did go and live in Denmark for a couple of years in his early twenties. He is now based either here or Southend so he has been geographically nearer as well as emotionally more accessible.

Separation and Single Parenthood

Andy and I separated when Erica was about one and a half in 1988, I moved up here to Crouch End and Andy stayed in the house we'd lived in, in Hackney. When we separated it was really because I felt the relationship was over it was my choice, there weren't any other people involved, I didn't have any particular animosity

towards him and I thought he was a good father. I know in some relationships when they break down the children can be used as a kind of bit of a tennis ball can't they? That just wasn't the case with us. Andy continued to be involved and I encouraged rather than tolerated it. For some women that is quite difficult but it wasn't for me. In fact it was quite liveable with.

I became a single mother with financial support for the children from their father not for me but for the children. Andy had regular contact with the children; he continued to have them for a lot of weekends and big wodes of the school holiday and he'd do things like come to their parents' evenings at school and come and see concerts and that kind of thing. He'd also come and visit them sometimes in my flat. They were with me from Monday to Friday and it was down to me to do all the domestic stuff, make sure the homework was done and they were in bed on time. I had other support as well; I chose to move up round here because I had friends living nearby. I think it's interesting when you share your children with a custodial ex-partner because you get used to letting your children go and be without you on holiday or whatever. It means that you have time, space and leisure to yourself. I have to say that as their mother I never worried about them when they were with Andy, I trusted him to look after them properly. I think that made a difference to the children because I don't think they ever experienced that feeling of divided loyalties, or feeling that they had to take anybody's side or anything. If I was ever critical of Andy about anything I would attempt to be critical to him in person rather than in front of the children.

New Relationships

Andy got together with Barbara very quickly after we separated. She'd been a friend of both of ours and I'd known her for as long as I'd known him. He'd known her for slightly longer than he knew me; in fact we met at the house she shared with her ex-partner. So Andy and Barbara got together about a year after we separated and it made things kind of easier because she was also single parent with two children Dan and Helen, and her two children and my two children knew each other. So in terms of our being a reconstituted group it wasn't as though the four children involved were having to suddenly get to know each other, they knew each other already.

Barbara had been more of a friend of Andy's than she had been of me but I was perfectly happy for the kids to go to her house or to go on holiday with her, Andy and her kids, no question about it. I suppose for the children in terms of continuity and stability that made it easier. It was probably also easier for me, that he got together with somebody everybody already knew, rather than somebody who perhaps hadn't got any experience with children or lived a long way away or even somebody who wanted children. The kids always had a good time when they were with their father and with her; they had great holidays and they got on with her two kids and still do. So from my perspective I felt that it worked out well. Its now sixteen years later and they're still together.

I was on my own with the kids for about six years before I met Steven. In that period of time I didn't have any other relationships with men, nobody that I'd introduced the children to; so they were used to having me to themselves. Just under a year after we got together we bought this house and moved in together. But when Steve came in we had this new dynamic. We had this man who hadn't got any experience of children, he didn't have any biological children of his own, and we were getting used to being in a relationship with each other. He was also taking on my kids.

Very soon after I met Steven Erica formed quite a strong relationship with him and she became the easy, good child with whom it was fun to do things and spend time with. Amber became the difficult, challenging, badly behaved one. Although she had been fine initially with Steven, she became really hard work. We had about two or three very tricky years with her from when she was fourteen to when she was seventeen and that was difficult. I don't know now that that wouldn't have been the same if I'd still been on my own with them or if I'd still been with her father. Of course it would have been different, but I think there would have been similarities.

Amber was just very rebellious. When she was round about in year nine at school, the year that we moved into this house she started staying out late. Drugs were involved, and not doing any schoolwork was involved. She wasn't involved in criminal behaviour, apart from the drugs, it was pretty standard teenage stuff, but she

was pushing boundaries all the time, all the time. I felt pissed off and frustrated with her because she was behaving appallingly. There'd be loads of rows all the time if she was here and if she wasn't here I'd be worried about where she was and if she'd be back. Steven would be worrying about her as well.

A lot of Amber's anger was aimed at Steve and it put our relationship under a huge strain. I was in the middle she wanted something from me and he wanted something from me. Steve found it difficult which of course he would because he'd had no experience of children of any age, let alone suddenly being in the middle of what felt sometimes like world war three with a teenager. My take on it is that she found it hard that he supported me in trying to get her to behave, do her homework, all the rest of it. Her take on it is that at the time he was telling her what to do. Because I'd been on my own for six years with the kids there were times when I just thought god maybe this would be easier if I was still on my own. I felt exhausted by it and just wanted to run away and let everyone get on with it without me. I don't really believe that now, it was my response to trying to juggle the complex dynamics of having a really tricky fifteen year old, a very new relationship, and of course my other child Erica who was nine.

The interesting dynamic around this is that it was one time in all the years I've known Andy that I took issue with him because I felt that he was colluding with her behaviour and not supporting me and her stepfather. I said to Andy. "What you are doing is less than helpful really, it's polarising me and Steve into being the bad parents and you being the dad who gives her money and takes her side". along the lines of, "fuck this! If you think that I'm overreacting" (I think was the word he used) "If you think I'm overreacting and that she's not really that difficult, why don't you have her to live with you for a couple of weeks and see what it's like". That made a difference because after about a week she came back to me and Steve because she didn't want to be there and Andy was a little bit more supportive after that.

Andy and Steven couldn't be more different. Andy's initial advice to Steven when Amber was really difficult was "well I don't think you should get involved". Steven

said, “but I live here”. It seemed that at the time Andy was thinking “well if this was me I would do it in this way” and that was what he was doing in his own relationship. Andy elected not to live with Barbara when her children were growing up, he only moved in with her after they were adults so he was much more hands off in terms of his stepfather role to her children than Steven was with mind. Barbara was bringing up her children and she was having a relationship with Andy but he wasn’t living with her. That persisted for quite a number of years.

As regards whether Andy might have felt a bit threatened by Steven, there may have been a bit of that in it. Andy was the man who had had two marriages, in both of those marriages he had two children, and in both of those marriages the relationship had broken down. So he had four children to whom he had not been a full-time parent for very long. I suppose there must have been an element of feeling something about the fact that his daughters were now living with another parent that wasn’t him and that he had chosen not to live with his partner and her children. He said to me once that he felt odd living full-time or living with someone else’s children when he couldn’t live with his own. Maybe that’s why his response to Amber being tricky was to collude with her, I don’t know. Also the nature of his work and his lifestyle was such that he is away a lot anyway. He’s an artist and he works overseas a lot of the time. Having said that, we got through Amber’s adolescence and although they are very different I think that Andy’s got a lot of time and respect for Steven and his relationship with Amber and Erica. I don’t think I could have done what Steven’s done. I don’t think I could have done it because it was difficult.

Situation Now – Reflections

I didn’t envisage that Amber and Steven would be able to repair their relationship and become close so one of the things that has been a pleasant surprise to me is that they have got a really good relationship now. I think that’s partly because Steven was very consistent. He stuck with it, and worked very hard at becoming a stepparent. Also Amber got through adolescence, left home, came back, grew up a bit and I think made an effort to form a relationship with Steven which is now pretty central to her life I think.

It is presumably no coincidence that I took on a relatively nurturing role at twenty one with the boys. I then hurtled off to be a nurse which is also a fairly nurturing role and after my first marriage broke up there was a sense in which I was trying to maintain and nurture the relationship that Andy had with his daughters. I don't mean for a minute that if I hadn't done that he would have walked away but I was very keen to try and ensure for the girls, that although they weren't living full-time with their father he still played a full part in their life.

I took on responsibility for the kids and I wanted to do it. I wasn't thinking "Oh I've got to do this" but I was actually embracing it. Not all mothers do feel like that. but I think that often, particularly with very young children, mothers that don't feel like that feel guilty about not feeling like it so it's a complex dynamic.

A long time ago part of my career a long time ago involved working in prisons with women who were serving custodial sentences in Holloway. A lot of those women were mothers and I saw that the kind of negative judgement and opprobrium that is aimed towards women who break the law is much more than towards male criminals. It's not just that they've broken the law, but it's that somehow they're worse because it means that if they're serving a custodial sentence, they're separated from their children. So I would say that mothers who break the law are seen as worse than women without children, because they've ended up in a situation where they aren't able to carry on with that nurturing relationship and society sees that that relationship should come first. More criticism comes their way because it's seen somehow as unnatural. So yes there is something about the nurturing role which I have taken on and if I look at virtually all my adult life its spilled over into the work I've chosen to do as well.

The whole family is now a group of mothers and fathers with a relationship towards all the children in some way or another, but with special feelings towards our own. That then goes into the next generation because of Richard and Jane's kids. They live in Brighton and they've got step-grandparents as well as biological grandparents. It sounds like a corny cliché but I think it's true that the more adults children have around to love them and support them, the better for them. My kids

don't have uncles and aunts and cousins they have a 21st century version of the extended family that doesn't exist anymore; the reconstituted extended family.

When stepfamilies don't work or they work badly children can feel less loved than siblings or stepsiblings or they can feel overlooked or marginalised. There can be a lot of rivalry as well, a lot of intense rivalry. One of the big differences in the stepfamily is that in a biological family you can have rivalry, you hate everyone or whatever, but the connection exists despite that; whereas in a stepfamily you can say to somebody you are nothing to do with me. And there is a reality that they are not connected. It seems to be that the blood thing is very powerful.

Talking about that and going back to thinking about when I became a stepmother to David and Richard and Steven became a stepfather to my kids, I don't think, unless I've edited it out, that David or Richard ever said to me, "you can't say that to me you're not my mum"; and difficult as Amber was during her adolescence she never said to Steven, "you're not my father, you can't tell me what to do".

I haven't said very much about David and Richard's mother because I've got very little time for her. I find her egotistical, self-centred, and I felt she neglected the children when they were growing up. Both David and Richard love their mother but she's not particularly nurturing or trustworthy or reliable. When David and Richard were small she worked as a musician and there were concerns around her not looking after them properly. She was very much, a reconstructed hippy and still is really; so she'd go off and leave them. The fact that Richard chose to come and live with us was because he got things living with Andy and me that he didn't get when living with his mother which was some sense of safety and continuity and regular meal times and so forth. So I've not got much time for Marge at all. I occasionally bump into her at the odd family event and last time I saw her was when Richard and Jane got married down in Brighton in the spring. We're always perfectly pleasant to each other but that's about it.

David has been very angry with his father for a lot of his life and whether that goes back to his parents splitting up, or whether it's because David feels that Andy should have realised sooner than he did that there were issues around Marge neglecting

them I don't know. David particularly will press his father's guilt buttons whereas their mother doesn't have any guilt buttons to press.

Andy has made an enormous effort with Barbara's children Dan and Helen in the last few years as they've become young adults. He now sees them as his stepchildren, whereas he was a bit more ambivalent when they were younger. My girls, Richard and I think David to an extent are very, very fond of Barbara and she's been great with all of them. When Richard and Jane got married in the spring, Dan, Barbara's son, was Richard's best man. He's also godfather to their little boy. So there is a step-sibling connection right across the family. Having said that David is separate because he's made himself separate and he dips in and out at the odd family occasion, but he is very tricky.

The thing that stands out for me is that when you talk about things you're talking about them from your own perspective; how you've responded emotionally to them, or what it was like in a particular point in your own life and your children's lives. For me, talking about it all, I think this is my take on it and I wonder what other family members' take on it will be. What would Andy's take be on it? what is Barbara's take be on it? because people do see things from different perspectives. It's fascinating how the same set of circumstances are experienced and distilled differently by individual people. The fact Barbara and my families are linked and because you are interviewing her, you will therefore get a different perspective on the same story from the other branch of the family.

Sally

In my family there's me, and Robert my husband, and the children are Ben and Olivia with Rory who I separated from twenty two years ago. Olivia is twenty five, Ben is twenty two. Then I've got two children with Robert; Lizzie and Frances. Lizzie is fifteen and Frances is twenty. I've been with Robert twenty one years. We started living together just before Frances was born.

Breakup of First Marriage

Rory broke up with me suddenly when we had been married for ten years. I met Rory as a student when I was nineteen and was twenty when we got married. I felt pressurized into marrying at the time by him. I think it was partly down to the influence of his parents; his mother was totally religious. Olivia was born when I was twenty seven. We moved to Bristol around that time.

I wasn't in paid work in Bristol. I tried to do some economics teaching when Rory said he'd cover with the children. That was a disaster because Rory was completely unreliable and he'd always have a last minute reason why he couldn't do it. It didn't occur to me to get any child minding or anything, so I just gave up. I tried to take an OU course too and I gave that up. I did run a small playgroup in my house which ran for a year or two until Ben was born, but I wasn't working outside the house.

I had a miscarriage in between Olivia and Ben but that didn't seem particularly significant in terms of our marriage, or even in terms of mourning for a lost child (it was quite an early miscarriage). Nevertheless I did have a strong reaction. I had a big haemorrhage, I lost a lot of blood and went straight back to full time looking after Olivia. I got quite anxious after that, I couldn't sleep properly and had anxiety attacks. I think of it as being less to do with grief at losing a baby as such – the baby didn't yet feel real to me – than being completely exhausted and being vulnerable to a sense of a loss of identity and direction. It was over suddenly and after that I felt I'd really sorted something out; I was much stronger than I had been before, after that experience.

All the same when Ben was a baby I did get depressed for a while. It was summer holidays Olivia wasn't at nursery and I didn't get a moment to myself. I was completely exhausted and would find myself in tears by lunchtime. It was quite a difficult time. Ben, born in late April was still exclusively breastfed and had a voracious appetite (at four months he was apparently the biggest baby they had at the local clinic, the weight of an average one year old, but he was only breastfed). Rory and I hadn't planned a proper holiday and he was obsessed by work. I was resenting it and we were arguing. It improved a lot for me once Olivia was back at nursery and I had a break in the morning when Ben slept for a little bit. The two of them went to nursery in the autumn and I used to get a few minutes to myself. I have a photograph of us at that time when Ben was a baby; we all look terribly solemn and unhappy.

When Ben was a baby I insisted on going to marriage guidance counselling because Rory and I were arguing all the time about his work. He kept changing his mind about where and when he was working. The plan was that he worked three days a week in Exeter, being in Bristol where the firm's computers were two days a week, and seeing more of the family; but he would change his mind at the last minute if someone asked him to do something in Exeter. After Ben was born he didn't seem that interested in the children. Nothing he had said in the marriage guidance sessions implied that he was thinking of separating and in our family backgrounds no one had ever separated or divorced or anything like that.

I was quite lonely at the time, although I had some friends down the road and in the next road as well; there was a certain community spirit around and I was friendly with a couple from the National Childbirth Trust Group that I had been in. Compared to nowadays though, I wouldn't describe any of them as close friends.

Things settled down for me a bit then but then Rory seemed to get very depressed, like he'd caught it off me or something. I noticed earlier in our marriage that if I got a really low patch or even a really good patch he seemed to experience something similar about six months later on. His work pressure seemed to be increasing and he

got very depressed. He had some weeks off work which I had been involved in negotiating; I had got concerned about how tense and depressed he seemed to be in the evening and had gone to see his boss (it was a small informal research company). When he went back to work he felt he'd been pushed out. In particular, one of his colleagues who was subordinate to him had been plotting against him. So he became quite determined to win his corner and fight back. I think he concluded from then that he couldn't cope with obligations at home as well, because he'd only been back at work about two weeks when he left us.

The evening before he left the marriage we had a row. I'd asked him the previous week if he was going to be working in Bristol on Ben's birthday. He said "Oh yes I am definitely going to be at Ben's birthday". I hadn't *asked* him to be around because by then I was so tired of all the arguments about that sort of thing, but I did think it was important for me to check and prepare myself. Then at the last minute he arranged a business breakfast in Exeter. We had this massive row about it (a business *breakfast* was a first – out of the norm entirely). He went off the following morning and phoned to say he wasn't coming back.

I didn't expect it at all. He had always gone on about how committed he was to me all the way through our relationship. The children were very young, because it was around Ben's first birthday and Olivia was around four. So, that's the age they were when I became single parent; I was still basically just at home with them. I stayed where I was and the children kept going to the same nursery.

Single Parenthood

It was a shock; it felt massive and things were so mixed up it was really weird. I had to find energy to adjust to the new situation and deal with my shock and at times I was absolutely furious.

It was a year of feeling exhausted all the time. By the time the children were in bed I'd lie down and then get up again to do the housework and clear up for the next day. I wouldn't get back to bed till around midnight and then Ben would wake at five in the morning and breastfeed. I arranged a child minder for two mornings a week so I could get on with things like working out my finances and making sure they were

organized. My Mum said I should be careful to keep records of absolutely everything I spent so that when Rory and I tried to sort of out the money side of things it would be clear exactly what I was spending, so that's what I did.

In regards to staying in touch with the children, Rory met with me about two or three weeks after he'd left and said he wasn't interested but that his friends had told him he'd regret it if he didn't see them and so he was going to. It was as though he'd completely turned and adopted a new identity. He'd re-cast himself as somebody who didn't want children but that I had wanted them and had twisted his arm to do so. It wasn't at all like how I had perceived it. I knew from his history that he'd made complete identity changes before in his life. For example, he had been bottom of the class at his comprehensive school, completely failing and academically completely useless. Then his parents had got him into this other quite academic school where he felt he had to prove himself and he went to the top of the class. So he'd gone from one extreme to the other. Then he had gone to university, failed his first year exam and then got first. So, this felt like there was something similar going on in that he'd changed identity.

So he planned to see them but he had nowhere to have them, so I found myself in this awkward situation where I had to leave the house to enable him to come and say with them for a few hours. I never got a break at home without them. That changed some time in the autumn.

It was a very mixed year. I'd always felt in part compelled to marry Rory and then to support him emotionally throughout his work crises. It was all very up and down he was quite a volatile person. I felt in part that I'd been playing this role and that the reason he couldn't cope with children was because he couldn't be a child with me any longer. I was now free of that and part of me was terribly excited. Even though I had the children I managed to proceed with some things that had interested me for years. For example I got in touch with a summer camp which had alternative craft weeks. I'd been vaguely interested before but if Rory had still been at home I would have never got around to going because family life and our relationship would have predominated. So I did some things that I couldn't have done before. That was

also the time when I sought more experience of counselling and therapy and I wrote a lot of poetry about the break-up.

When Rory got a flat in the autumn he had the children for the weekends. I was very worried about that because they seemed to find it quite disruptive but it did mean I had all weekend without anybody around and I quite enjoyed that. I hadn't had that sort of freedom for years. I had begun to come to terms with being a single parent which was completely outside anything I had ever expected.

But alongside that there was an incident in the autumn when Rory wavered about his decision to leave. He came back one evening to talk about things and we ended up going to bed together and I had this shimmer of, "maybe we'll get back together." I decided at the time that I would be prepared to do that because when all was said and done, and despite my periods of feeling immense freedom, I had an overwhelming feeling that I wanted the family back together. I thought that there wasn't any reason why we shouldn't work on what was wrong through family therapy, but he had previously said, just after he first left, that he wasn't interested in doing that because it would be far too much trouble; he just wanted to get on with his work.

After that he didn't get in touch with me for a few days which was confusing and when he finally did manage to get in touch with me and he said he wasn't coming back. He said that I bewitched him when he came back for the night and that he didn't really want to stay. The episode really threw me. That's what I found most difficult of all around this entire period of separation and stress. Rather as though I had given my soul away and couldn't get it back.

However Rory did then ask if there was anything I really wanted from him and I said, "Yes, I want you to take the children for five days because I want to go down to a residential group about bereavement and divorce." So, I went down to the residential group which was run by people who were doing similar work to that which I eventually trained in. That was another thing because I took an interest in it all my life from then on.

Some Personal Background.

I had three brothers and I was the second child, but I was aware of our family being quite socially isolated. I didn't really have any, childhood friends. I had one who emigrated to Australia and another was who was in the year below me but on the whole I didn't meet any other children. There something about my dad and him being depressed and angry too. I remember thinking about him very critically the way teenagers do "he's put all this effort into trying to do good in the world, but it doesn't really work because he doesn't really understand himself. What's the use of trying to good for other people if you can't even relate to your own family?" So, the idea that you could somehow do your own psychology was around for me in a vague way from when I was quite young.

When I was at university counselling was a very odd thing to do. When I look at my life, I see what a difference it would have made if there had been student counsellors around like there are now. I'd have definitely gone when I was engaged to Rory if there was somewhere to go. I was so aware of wanting someone to talk to and there wasn't anybody. I think my life might have been very different.

From when I first graduated I had been interested in Child therapy. I remember thinking I would like to work with children who are disturbed. I thought that I should have studied psychology with my philosophy. My interest came because I was aware of being lonely as a child. I remember thinking to myself, "If I was so quite miserable for some of my childhood then other children must be much more miserable and I'd like to do something about that". I went into teaching training with that in mind but in the year I qualified from teacher training it was very, very hard to get jobs and I didn't actually teach, I did a research job instead.

Then I got pregnant and Rory and I decided to move out of London so the whole thing about work didn't seem quite so urgent. Although, I hadn't really meant to stop work entirely that's what happened.

Around the time that I was doing the research job it was suggested to me that I might seek counselling. Although I took it seriously at this stage, getting the right job seemed the key issue to me; and I was also worried that having to go via the doctor

would mean it would be something I would need to put on my job applications, which made me nervous. So marriage guidance counselling was the first experience of anything resembling counselling that that I'd ever had. Then after the marriage broke up I went to the residential thing (mentioned above) with some Neo-Reichian based therapists. It was mind blowing; quite extraordinary to me that people could hear me or recognize me in the way that they did. I came back very fired up about it thinking "well in my childhood the church kept *talking* about love but I never experienced any of it. But this is *living* something about love". I went back a second time around the anniversary of when my marriage broke up, by which time I was involved with Robert.

Meeting Robert

I met Robert through some friends. There was a work colleague of Nick's who came to see me. This man had worked for Rory and left because he said he couldn't stand it. Through this chap I got in touch with two people from my university and they mentioned another man who lived not far away. They came down to visit and spent a night or two with me and a night or two with Robert. While they were with him they persuaded him to invite me over to supper.

The next time Rory had the children I planned to do a British Trust of Conservation work party and it was up near where Robert lived. Rory had the car so I bicycled all the way to the work party and then on to see Robert. It was quite a long way out of ***** much further than I expected. I remember sitting on his work surface in his kitchen, swinging my legs and chatting away. Then he invited me out to a concert. It was very rare for me to get out and I had to phone up Rory and say, "Will you keep the children for an extra night?" in order to go. So, I was very excited.

How I felt when I met Robert does echo what happened with Rory, because when I met Rory he showed me all sorts of things I had never done before. Both Rory and Robert came from slightly more wealthy backgrounds than my family. It was all quite exciting for me in that respect apart from anything I felt about them, a bit like introducing me to another world. I remember with Robert, on that very first occasion, it was as if it was the first time I had been out. I was quite excited; not so

much by about getting out of the house and away from the children for an extra evening in order to do something with somebody else.

Robert had never really been involved with children before although he shared his house with a family with children. He had moved out of London to this village near ***** and it was quite a big place for a single man. He therefore shared it with his work office so there was a consultancy office in his house. When I met him the office was moving out and a family with three children were moving in to have a little more space at the weekends. In that sense he did live with children but it was in a very detached relationship.

Robert started asking to come around to my house early evening after work and I got quite tense about it after a while. I found it difficult because I had my bedtime routine with the children and if someone else was around who didn't really know them well it upset their routine. I remember asking him not to come at that time. I felt quite conflicted and confused because I was split between appreciating support for my family and wanting to be free. We had got sexually involved very quickly, but I kept wanting to pull back. But I did feel very emotionally involved with him.

Getting Pregnant

I had a pregnancy scare even before I got pregnant with Frances. It was unlike when I was with Rory as I never had any scares with him and it was dead easy to plan contraception and so on. It seemed very easy to do what we were supposed to do, whereas when I was with Robert I felt like we weren't quite clear. We started using condoms but then I said I was happy to use my cap but it didn't seem to fit very comfortably anymore because I hadn't used it since before I had children. Even though I went and got another one it still didn't feel comfortable. I got scared that I was pregnant about two months after we met. I had decided that I couldn't cope with having another baby on my own because I'd been quite drained by Ben only being a baby when my marriage broke up. I didn't have spare money to employ any help and I just couldn't see how I could do it. Therefore I knew that if I was pregnant I would have an abortion but in fact, I wasn't and that was alright.

But then about two months later I really did get pregnant. I couldn't work out how I could have conceived at all because I had been combining the rhythm method with the cap and condoms; I was quite skilled at that and I knew my cycle exactly, when I was fertile and when not. We were therefore completely bewildered and shocked to find that I was pregnant; it wasn't in any way it was planned at all.

I felt sufficiently close to Robert by then to want to keep the baby, but it did feel very scary because I knew that there was no way I and the children could cope with having a baby in the house if I was on my own. I also knew I couldn't possibly get a baby adopted because it would be far too upsetting for me and for the others – well for Olivia actually. When I got pregnant I was going through all this in my head. Robert then went to America for a couple of weeks at a time when my energy levels seemed about half what they needed to be. It really hit me trying to look after the two of them while I was pregnant on my own. I was back to feeling sick with tiredness by the time I got Olivia into bed and I got really worried. I thought, “I don't want another baby. I can't cope with another baby and I don't want to be tied to feeling I've got to live with Robert because I've got the baby.” But after he was back I went off for a couple of days to think about it and decided to continue with the pregnancy.

By then Robert wasn't generally working. I think he was in between jobs. His company had a rotation system whereby the foreign consultants like himself would take a stint in the office so, when I met him he was working in the office in Bristol. That finished while I was pregnant and he was waiting for another appropriate job to turn up. He wasn't worried about the finances as he had enough to live on in between jobs and was quite well off. He hadn't completely moved in with me, he kept his stuff in his house but he was around a lot.

When I was pregnant this time I was desperate to retain my autonomy and my independence. I was clear that I didn't want to marry Robert while I was pregnant and it didn't often come up as a subject between us because he wasn't suggesting it. In fact originally, he said he'd always thought that marriage was a bad thing anyway.

“What was marriage if it was tying and removing your freedom”. At that stage I didn’t want to either, but I wasn’t anti in principle if I felt committed to somebody.

Robert was quite involved with the children. From the beginning he would change Ben’s nappy which I was terribly impressed with. He was quite good at throwing Ben around the bed which Ben loved.

Impact of the New Baby

I think the arrival of Frances had an enormous impact. The fact that there was a new baby who was Robert’s made a huge difference because everything revolved around her. Even Olivia was obsessed with her, although, she also reverted in that she went back to pretending to be a baby like she did when Ben was born. That was the way she coped.

I can’t really explain this but the minute Frances was born my feelings changed a lot. Up till then I was worrying “am I losing my freedom?” But once she was born there wasn’t much point in worrying about losing my freedom because I had lost it!

(Laughs) I mean, that’s not true, but once the child is there all that matters is looking after her properly; its an immediate thing. All concerns about my autonomy went out the window. I had a lot of love towards her then and towards us as a couple wanting to look after her. So, I had a very strong sense of connection and I was quite keen on getting married then. I kept quiet about it for around three months.

Robert was over the moon about Frances. I remember thinking as a single parent that no man would be interested in me because what man would want to take on two small children? So, I had resentment around that. Robert was aware of having been sad he wasn’t in a long-term relationship and was very consciously looking for that – which surprised me – but he’d never thought about wanting children, however he actually seemed quite interested in the children (Laughs) and he was fantastic with Frances, who, although most of her life was the easiest of the children for the first six months was the most fretful. I was quite surprised. (A part of me thinks, “Was that because I was torn in two when I got pregnant with her?”) I was quite surprised by how involved Robert became with the children.

I managed to organize an au pair because I thought that without some help there was no way Robert was going to be able to enjoy having a baby because he'd never had children before and it was going to be a complete shock. He still didn't know the full weight of having Olivia and Ben around all the time. I thought "to go from no children to three is a bit much and they were all under six; three under six!" So I got an au pair for the first and only time in my life. (I did try one or two other times to get an au pair but this was the only time it came together in a positive way). She left at a rather bad time so that wasn't positive, but for the first few months she was great. So that first six months were a very, very precious time because she was there to help to look after Ben and take him for walks, or do the housework and Robert was doing housework as well so all I had to do really was look after Frances. It felt very warm and supportive. When Frances was about four months old we decided to get married in the summer.

Impact of Situation on Older Children

Rory continued to see Ben and Olivia first of all in my house, and then when he got a flat in London he would take them off for the weekend. The visits had all sorts of implications for the children's security levels and were quite disruptive. I remember very, very vividly that Ben who was two and basically out of nappies, would be dry at night with me, go off to visit Rory and wet the bed when he got back. Olivia also used to come back quite agitated after seeing her dad. She would look forward to it but then she'd come back hyper but then she'd come back hyper and it was very, very difficult to get her to school the next day. After Rory had left the marriage I had had lots of trouble getting her to go to nursery. I did usually get her to go but I had to stay half the morning or I had to take her guinea pig with us.

Olivia was three when Rory left and although she remembers seeing a couple of really unpleasant quarrels between us before then, her behaviour changed after he walked out, not before. At the time she didn't really know what was happening and I wasn't sure that he was leaving for good or not, even though he said he was; so I couldn't really explain to her what was going on. Before she would let anyone baby-

sit wasn't fussy and was really outgoing; but after he left, I had awful trouble with her having separation anxiety. She just didn't want to leave me anymore.

Even the following year when she started at "proper" school, after Frances was born, she would still cling and cling to me. As I said it was particularly bad if she'd been to Rory's at the weekend. It would be next to impossible to get her to go to school the next day. The teacher was quite good, would take her and let her sit on her lap and she'd get into the routine, so that she was better later in the week. I'd walk her over to the school the mornings after and I either had to leave her screaming or I had to stay half the morning. It was really difficult. Sometimes I gave in and I'd just keep her at home. I never felt that was very good because then the problem was compounded. Looking back though I wish I'd done that a bit more because she might have relaxed if I had kept her at home for an extra day but I couldn't really by then because she was four and in proper school. I think loads of parents have this sort of problem with children who go on access visits

In the summer when Frances was five months old Robert took a job abroad. He was away for three weeks without us after which we were due to fly out and meet him. He'd been away before for ten days at a time when Frances was very small and I still had the au pair, but this time the au pair decided to leave the same week as Robert did. The kids were used to having three adults around full time and suddenly they had only had me. It affected Ben an awful lot because he'd had a lot to do with both the au pair and Robert. So I was worried about Ben; I was very aware that two significant people in his life had both disappeared the same week.

First Visit to India and Difficulties the Following Year

I was going for the whole summer to India with three small children and I was scared about going for the same sort of reasons as I'd had previously had in regard to Robert i.e. I was worried about being dependent on a man and leaving my friends, such as I had, behind. Was I going to like being in that sort of situation in India? Robert was working during the day, would there be anyone to talk to or to see?

In fact, we had a fantastic time. I really, really liked it. Robert was working in the day, but wasn't very pressured at that job. He was able to have lunch with us and we'd meet at the pool some days. We considered staying out there and trying to get the children into schools because Robert had more to work to do but there was also Rory to deal with. In the end we decided it was all too complicated and we came back as we had planned and Robert went out again separately.

I was struck by the fact that when we were in India that time for six weeks I had never seen Olivia so happy. It was as though she was young enough that being in a completely different country with a different climate where there was no question of her seeing Rory meant she could completely forget about him. She threw herself into just being part of a new family with Robert and me, Frances the baby and Ben, and never talked about Rory the whole six weeks. She was so happy; I've never seen her so happy before or afterwards.

Overall though I think the combination of Robert doing short term work abroad with having had their original father leave was very difficult for both the children. For Ben in particular Rory's leaving had very little discernable effect because he hadn't had much to do with him. Rory had been obsessed with his work before Ben was born. He hardly ever had put Ben to bed or anything, and I was breastfeeding. But when Robert left to go to India I had a sense it would be worse because there must have been some sort of echo of the prior leaving. Ben didn't show his disturbance immediately but when he arrived in India he was very angry with Robert and wouldn't speak to him at all. He rejected Robert and wouldn't really let him touch him or do anything. I never asked Ben whether he remembers any of this because I assume he was too young, but Robert would certainly say that his relationship with Ben changed and that he never, ever got back to having a comfortable relationship with Ben again after that – till Ben was an adult really, in the last few years.

The following year was difficult for me as well and confusing for the children. Robert went back to India for two six-week stints without us because both children were in school by then. Rory was in a new relationship who was someone he had met at work. It was difficult for Olivia and Ben because during that year because

both Rory and Robert were doing long trips abroad. There was a series of weekends where Rory had gone abroad and Robert came back after having been away for a long time and I thought, "God! This is so confusing for them!" Olivia would still not stay at school very easily. After her second year she had got used to it but, she went through a stage where she would crawl under the table when she knew Robert was coming home for supper and start screaming. That in itself didn't seem so bad, but a bit later on there was a stage where she got so hysterical when Rory had dropped her and Robert was due to come, that I got really, really worried about her.

We were so concerned about Olivia that we took her to family therapy. We only went three times because she wouldn't go back. I really questioned the way they worked; that sort of intensity with children that young. It was a small family therapy centre that had recently opened and we went on a two or three week waiting list. They were helpful in a way because they saw all three children falling all over me and Robert and I described how we had this habit of having in depth heart to heart talks at three o'clock in the morning in bed because it was the only time we had on our own. They made a helpful comment on that and I felt the level of day-to-day stress around us was recognized.

They tried to get Olivia to talk about Rory and in a way it was quite constructive but I think it was also quite traumatic for her. Unlike Ben she was very devoted to Rory and he had been very warm with her when she was a baby. They asked her explicitly about her dad and what came out was that up to that point she had held this fantasy that Rory was coming back to live with us as well. She said, "Why can't Rory move back?" and I said to her, "What about Rory's wife Joan?" and she said "Well, she can do the housework." (That's a wonderful picture of importing my ex-husband's wife to do all the dirty work in the house - all the washing up! Yeah, right!) So, she had this idea that Rory and Joan could move into the room in the garage and Robert and I could live there too and that we could all be a nice happy ménage à quatre. But after they pointed out to her that Rory wasn't coming back she came into our bedroom the next morning and went into the corner screaming; so, she really found it quite heavy. I think it did help having it out in the open that Rory was definitely not coming back. This was two years after the he left and I was

powerfully struck by the fact that in all that time she had never really accepted that he had gone.

I never at that stage thought that that Rory maltreated Ben and Olivia in any way. I always assumed, and I still tend to think of it like this, that the stress of him seeing them was the stress of the change; the stress of adjusting to being with him and then adjusting to being back to our house.

Going to Live in India

Robert and I immigrated to India the following year. Robert had been working in India previously as I mentioned before and he got himself a job directly with the government and we lived there for three years. That's when we really started to have trouble with Rory, who had treated me quite reasonably up till then.

Rory behaved very weirdly over us taking the children abroad. His first reaction was more or less, "Good riddance. So I won't have to bother to see the children. It's a terribly hassle. So, that's actually fine." I went to see our lawyers and they said, "Well, if you are in agreement there is no need for a court order. As long as you've got his written permission there is no issue. You don't need to go to court or get anything formal, it will be fine." But, for some reason *his* solicitors were saying we had to get a court order and so he mentioned this a few times. Robert had already been over in India and flew all the way back so we could go out as a family when we finally left. The night before we were due to fly I had been up all night, doing the final cleaning of my house which I had arranged to let. I got back to Robert's house very exhausted and then Rory phoned me up making threats like, "You realize that I'd be quite within my rights to put an injunction on the airport to stop you going because you haven't got a court order?" It was all very surreal because he'd already given his written permission. (Not that I believed for a minute that he would do what he threatened). He wasn't denying he'd done this but he had suddenly got upset that the children were leaving and he sounded pretty threatening. So there was some very volatile stuff going on between me and Rory and he certainly succeeded in upsetting me.

(The actual problems with setting off to India were rather different in the end. We went to the airport and they didn't have any seats for us because there was a muddle about where the tickets were booked which was down to Robert's company. So there we were with three children under seven, emigrating on an international flight and we didn't have seats on the plane! Eventually they found out as some other people either didn't turn up or got off).

We had some difficult years in India. One problem was that Robert had quite a battle issue with Ben because he never quite seemed to get that little boys are very boisterous. It wasn't an issue with Olivia who was very good in that sense. Robert didn't have a problem with Frances either who was just a toddler. Ben wasn't good with table manners and was often jumping up and down in the middle of meals, or running out and shouting; he had a very loud voice. I was very protective of him and that caused tension between me and Robert. I had the feeling that I couldn't get the balance right because I was always trying to compensate with Ben because Robert would be quite strict with him. I seemed to be forever trying to explain to Robert that you didn't need to be that strict with a three or four year old and that Ben couldn't necessarily live up to the standards that Robert was expecting. I remember a lot of tension because rather than letting it drop I'd get really upset and worked up with Robert for not understanding children. I'd shout at him for not being more tolerant?

No one seemed to understand Ben. My mother came out to visit a bit later on when I was pregnant with Lizzie towards the very end of our stay in India. I was quite ill during that pregnancy; not medically, I just felt terrible. (Later on I found out I was anaemic). I was feeling guilty because I was ill and kept lying down. I was trying to keep the peace between my mum and Robert around the kids and stuff. We were travelling and Ben was doing something in the kitchen. I remember my Mum screaming at Ben and us for not keeping him properly under control.

Sometimes I got frustrated with Ben as well. I used to think he might have a tinge of autism what they now call dyspraxia; when children aren't very organized with their movements. He didn't really know what other people were doing and was

completely in his own world. So, he would sort of be noisy or inappropriate and have these repetitive behaviours like getting his toast and putting it back in the toaster. That's the sort of behaviour that used to drive people nuts, particularly my Mum and Robert. He grew out of it, but he was very much like that until he was about seven when it was as if he suddenly woke up and thought, "Oh, that's how you do it. If you don't bang on the table or mess around with your fork and knife, people like it and people prefer it". The girls picked up social behaviours instinctively but he couldn't learn any of these things that way and had to work out in his head how to behave and treat people so they wouldn't get upset. Even now sometimes he still fiddles like crazy. He does this trick with his spoon. If its mealtime, you need something off the table and you just can't find it; it's probably because Ben's been around picked it up and fiddled with it.

In India I got into the state I was scared of getting into when I met Robert. I felt under obligation to him for taking my family on, making us financially secure and putting effort into supporting me emotionally with the children in a way that Rory had never done. So when he said the children should be doing such and such or the children should behave like this, I used to get confused and lose confidence that I did know what was best for them. I'd think, "Perhaps I am wrong? Perhaps I should be shouting more at Ben when he won't sit down at the table?" I did feel very caught at times between wanting the children to behave right with Robert and for Robert to behave right for the children. I was the one in the middle. Now looking back I feel embarrassed and sad because I didn't have the courage of my convictions and I think in almost every instance I was right. The fact was I knew how to look after children and Robert didn't to the same degree. I've always been interested in children and I could see things through their point of view instinctively. Also, I had had three years of bringing them up before I met him.

We had problems in India around schooling and housing. During the first year we didn't have housing for nine months during which time we were all in temporary accommodation. Then we had problems with schooling. We got schooling for both Ben and Olivia but Olivia had a terrible teacher and I took first her and then Ben out of the school. Olivia went on to another school and I was told that because she was

already there they would find a place for Ben but they didn't and we never found anywhere else. This meant that Ben ended up being home educated the whole time we were there except for one term.

The most stressful problems we had when we were out there were to do with Rory. We'd made an agreement before we left that we would bring the children home every summer and he would come out to visit them at Christmas time. The first year we put an enormous amount of effort into his visit. I did all the research about where he could go and where he could stay and got quite tired. We had faxes going to and from Robert's office and I did everything Rory asked me.

That first time Rory came out to India he took them to Mauritius, which I was really surprised about. I thought, "Well why didn't he just take them somewhere here?" The day Olivia got back from Mauritius she went under the table and I remember her screaming, and screaming, and screaming, and screaming, and screaming with Robert and me taking turns sitting with her. I just attributed it to the shock of having to switch homes.

Afterwards, when we were back in the hotel where we were living Olivia started saying to me, "Joan wants me to call her Mummy. Can you tell me how to spell it?" I wondered "how on earth do I deal with this because I really don't think I am comfortable with them calling Joan Mummy, because she isn't her mummy". I said, "You can call Joan 'Mummy' if you want but you'll have to get someone else to tell you how to spell it because I don't want you to write it, so I am not going to help you." I remember staying quite calm but being really thrown by it.

The third year we were in India Rory started campaigning for me to send Olivia and Ben back the following Christmas rather than him coming out. We had been trying to discuss what would happen after we came back from India and whether they could alternate Christmases with us.

Legal Issues

Looking back I regret what I said (a bit, but I completely understand it too), which was that I thought the children should stay with us for Christmas because we had

brought them up. I was basically still angry that Rory had walked out on them and I had an issue with separation as well. Rory and Joan seemed to accept my argument and didn't make any fuss about it; they seemed very friendly. But after we got back to India it was obvious that they hadn't said what they really felt because I started getting nasty letters from Rory's lawyers which said they wanted Olivia to fly out for Christmas. I was really quite shocked by getting the letters.

The problem was that Olivia got very, very airsick whenever she flew and she was terrified of going without me. I didn't want her to go, but she was old enough by then that if she was keen on doing it then I didn't have a major argument against it. I thought if she was happy to go I had to let her go. But every time I tried to broach it with her she got really upset, so I would leave it for several weeks. That was very difficult.

Meanwhile we were getting nastier and nastier letters from Rory's lawyers. The letters accused me of not being fit to make decisions. They started dragging up all sorts of things such as questioning my capacity to home educate and saying that the children weren't being educated properly, even though the children were doing well in respect to school. They dragged up things like the fact that Ben had caught dysentery when we were in India and anything they could to try and show that I wasn't fit to look after the children. They even drew up a list of my unreasonable behaviour when I was married to Rory. The bit that amused me most said that I didn't cook him meals properly because they weren't on the table when he got back from work; when I was looking after two small children! The argument wasn't really relevant. They weren't trying to take the children away but to use it all as a background to their campaign for them to go home the following Christmas. We actually thought we were going to have to go to court over it because Olivia was still refusing to go and the solicitors were saying that I was refusing to let her and Ben go.. I found it a very scary situation because I did know that Olivia was still young enough that if a social worker spoke to her, she might suddenly change her mind and say "I do want to go." There was the possibility of making a huge court case over this thing that might have shifted anyway.

Eventually what happened was that just before we were due to fly to England for the summer which is when the court case about the following Christmas was going to be, I asked Olivia again. I said, "Well, you know, we're going to have to talk about whether you are going to England for Christmas or not and what you feel now? Are you still sure you want to stay in India with us rather than to spend Christmas with Rory in Granny's house?" This time she said something a bit different. She said, "Why do I have to decide now? Why can't I decide when it's closer to Christmas so I can tell what I feel like then?" (they were asking a nine year old to decide in July what she wanted to do at Christmas!) I said, "The reason you have to decide now is because we are going to court." I had to explain the whole thing to her and what a court was. She said, "If it's causing that much fuss I better go." I was due to meet Rory anyway because they had arranged a family meeting at a conciliation service. I hadn't bothered to call before but I turned up at it and said, "Well there's not actually an issue about this any more because she's now agreed to go." So, that was that; except that I was left absolutely fuming about the whole thing. I had been under strain for months, and months, and months with it. I walked out of the conciliation service and Rory was behaving as though nothing was wrong. He asked if I would like to have a cup of coffee or tea. I just said, "No thank you," and walked off. It was quite something for me because after that I didn't trust him about anything.

Back in England and Older Children Entering Teens

There is no doubt Rory's attitude towards me changed once I met Robert. I think that as long as he had a wonderful job, a new marriage, new woman and everything he enjoyed feeling sorry for me with two small children being on my own. He always behaved very nicely to me in the first year. After he realized that Robert and I were serious and that Robert had quite a bit of money as well he started behaving much more nastily to me.

There was a patch when we came back to England where things seemed to settle down. Lizzie was born about five weeks after we got back to England and the same year Rory had another baby. I had a settlement with Rory which seemed perfectly reasonable for a change. Also Ben grew up. Although Robert and I still had

occasional big battles about him when it came to really important things I often agreed with Robert.

I suggested that in order to try and reduce some of the disruption we had experienced between their visits to Rory and going back to school that they visit Rory every three weeks once they were back in England?" As the children hadn't been used to seeing him regularly at all I think they were quite relieved when he said, "Yes every three weeks is fine." Robert was abroad and I felt resentful about having to help with the transport and drive them over to Rory's. I thought it would be really difficult doing all that with Frances and Lizzie as well so I resisted offering to ferry them. We came to an agreement over that quite easily because Rory by that stage was pretty wealthy. In return for him paying me a bit less maintenance he paid for a taxi for them. So there weren't any arguments about transport they got picked up by taxi and driven to Rory's which was about £50 taxi ride. Later on they went by public transport but at this stage they were still only seven and ten years old.

Schooling

We had one other major negotiating episode with Rory at that stage which was around Olivia's schooling. Because she'd got back from India at the age of ten she found it hard to settle into primary school. Most of the girls in the village had been there all their lives and she was quite unhappy and lonely for a while. She also found it quite a culture shock because over here of ten or eleven were beginning to dress like teenagers and were sophisticated in a way that Olivia was completely unused to. In comparison she was quite naïve. In India there was no pressure to be fashionable so she played like a little girl. I liked her wearing these little girl dresses and she liked them as well. There was no question of her wearing makeup or tights and we didn't even have television but there was a lot of all of those things around in England. The younger children Frances and Lizzie they would have never worn the sort of dresses she did at that age; by then they were wearing jeans or short skirts. I've got these beautiful twelve-year-old dresses that I kept, thinking the other girls would wear them but by the time they were that age there was no way they would touch that sort of thing.

Olivia had just settled down at the primary school when she had to transfer to comprehensive. At this stage Rory had already offered to send her to private school, but none of us took it particularly seriously and he didn't seem very bothered about it. I think it was all too much adjustment in too short a space of time. She started asking to leave the comprehensive school and whether there was any way she could go to a Steiner School. It turned out she had been doing much worse at comprehensive school than I realized. She'd been lying about what homework she had, because we'd been told they would be given some every day, and would insist that she had none and show me her empty book. It turned out she'd just been not writing it down. I still don't really understand what was going on that term, and now looking back I wonder whether she was more disturbed than I realised.

I had become involved in the Steiner school system, partly through educating Ben at home and because when we got back to England there was a Steiner kindergarten nearby where we sent Frances for a very short while and then we used to take Lizzie to a toddler group there. I had the brochure at the house but I had never suggested it because it was to her because it never occurred to me that I could persuade Rory that Olivia should go. However she was very determined to go to a Steiner School. Looking back it's clear something inside her knew she was in a lot of trouble at the comprehensive and not coping, and wanted a radical change and a more nurturing school environment. We went to visit the school and then we contacted Rory. He still said, "Why don't you go to another private school?" but I wasn't particularly behind it and Olivia was just interested in the idea of going to a Steiner school, so he agreed.

She became a weekly boarder and was clearly very determined in regard to her new school because she coped with the long bus ride and everything. I can't remember exactly how we got her there every weekend now. She used to get a bus and a father from the school who worked round there picked her up. We used to make the trek down there often for all the parent's evenings and stuff. It's not like some boarding schools where you are only expected to turn up once a year for something and I am not that sort of parent. We had to go there regularly. Initially Olivia seemed to really benefit. She loved her school work there and where she used to hate science

she now loved it. When I picked her up she'd come home singing all these songs in the car and I thought the school was really doing her a lot of good. I got really inspired by the Steiner system and did some of the training

Before this happened, I hadn't thought of moving to a Steiner school because it would have disrupted Olivia again and because all of them had had far too many moves in their lives I didn't want to move them again. But, once Olivia decided she wanted to go there I thought that there was not much reason for staying where we were which I wasn't that happy with anyway. We decided to try and put the younger two in Steiner school and we looked into moving near Olivia's school so they could go there.

Ben's Schooling

Rory wanted Ben to go to a private school and I had wanted him to go to the local comprehensive here and stay at home. In the end I decided I'd better ask Ben what he wanted. I knew he was a bit young to make a decision, but unless Rory and I were going to agree it was difficult to know how to do it. Meanwhile, Rory suggested places near where he lived. That would have been a nightmare for me because of the travelling involved, on top of travelling to Olivia's school and the two younger children at home. I also didn't want that sort of social milieu for Ben and didn't think he would feel at home. But there was a Quaker school in the nearest town and Rory was quite impressed with that. He visited it and said he liked it. So that's where Ben went. He tried going as a day boy but it was too far and he was exhausted, so he ended up weekly boarding too. That was quite difficult for me, and for him; he would phone up clearly quite lonely but not really able to make conversation, and I couldn't engage with him in the way I could have if he was at home; normally I was trying to make tea for the two younger children at the time! But the school did seem to understand him quite well.

So it is true that Rory was involved with his children's education in a way that Robert wasn't. Both Robert and I felt that Robert lost a lot of money over bringing up the children because, apart from the direct costs, due to the strains and complications of our family life he'd taken a lot less work than he otherwise would

have done in order not to go abroad so much. Robert was very resentful against Rory really and he was pretty keen that Rory should pay for anything that he could be asked to pay for on principle. Therefore Robert wasn't going to offer to pay for private schooling – or even Steiner school – as long as Rory could be persuaded to pay for it. Rory seemed to be actually quite proud of how much money he made at that stage so he was happy to do it.

It was just about as soon as we had moved to our current house that there was this issue about Ben's secondary schooling and I went to London to meet Rory to talk about that. It was the first time I had met him for a long time and he was his usual sort of charming sort of persona with me but I felt pretty resentful towards him. There wasn't any healthy communication; the discussion about Ben's schooling was okay, but other things that weren't great. Partly this was to do with the aftermath of the court case and so forth, and partly because of issues that were coming up with Olivia. For example he asked to have them for New Year and if she'd stayed here she would have had a really nice time but she went over there and they just used her for a babysitter. There she was twelve years old, and she was stuck in the house looking after their kids while they went out and had a fancy dinner! .She used to get in trouble because they'd go to the supermarket and Rory would buy them things; they would get back home to Rory's wife Joan and she would say, "Why have you bought that?" and Rory would say, "Oh, the children asked me to." I was getting these stories that he would be extravagant with them and then they would get blamed for it. Olivia was often upset about the way Rory was treating them I had once or twice phoned him to say, "Olivia's a bit upset about this do you think you could look into it?" Eventually she said to me, "Don't ever talk to Rory about any of this because it makes things much worse; he's really cross that I have spoken to you." So it wasn't easy between us with all that going on and once Olivia and Ben were in secondary school and entering teenage years, things began to deteriorate again between us.

Difficulties with Olivia

We moved here when Olivia was twelve and about a year after that she started showing quite disturbed behaviour. I hadn't experienced teenagers before and

people kept saying to me, "Teenage years are difficult!" so I thought "I know I wasn't like this as a teenager but this must be normal she's obviously a very sensitive child and very upset about Rory leaving in the first place. That must be what's causing all this". When she was thirteen I remember her screaming in the garden and saying she hated Rory. I was surprised because she had always been devoted to him even though she had criticisms. When her breasts started growing she was saying she hated her breasts and she didn't want breasts and this sort of thing which seemed a bit unusually passionate. At around that time I came to the conclusion that I had to make quite sure I had nothing to do on Fridays or Friday evenings because she would come home and start being hysterical every Friday night that she was home.

I thought something was wrong at school so when she was around fourteen I went down there for three or four days and talked to staff in the boarding house where she was. I couldn't pick up anything from them other than that they were all taking care of her and some of them spent ages supporting her and talking to her. A while before her GCSEs the school insisted that they found her a counsellor as it was quite clear that she was terribly emotional; she was always getting upset about things and clinging to people quite a lot. It was difficult to believe that it was because the school wasn't the right place for her, because the first year or two she seemed to really thrive. Much, much later her counsellor said she had realized that Olivia was in a far worse state when she came back from visiting her dad than when she came back from staying here, but I don't know why they didn't say so at the time to somebody.

The situation dragged on. I can't remember exactly what happened, but between the age thirteen to sixteen when this was really developing she would talk endlessly about these other girls. Steiner schools attract children with problems, or parents looking for solutions for their children and there were two other girls in the boarding house who were quite disturbed. I was getting stories all about Jo who had been anorexic since the age of eleven or twelve and had been hospitalized at one point and about another girl who used to self harm. I can't quite remember what this girl's main symptoms were. She was into drugs, but the school was very, very strict about

that so I am not sure she would have survived there if she was using them at school. Looking back now with the perspective of my fifteen years psychotherapy experience I think that if a child starts telling stories about other children I'd wonder why and think they were giving some important messages about themselves – well on one level I knew that but I didn't know what.

Rory invited Olivia and Ben to Greece so she went off there and just after she came back the school rang up, said she'd cut herself and said that I had to take her to the doctor. I did that, but the doctor dismissed it because he'd talked to her and had decided that there wasn't that much wrong. She'd managed to talk quite normally and cheerfully to him so I guess he had the wool pulled over his eyes. There was a cycle with her where things would settle down and then there would be some episode at school where they rang me up, or I'd become worried and we'd have another discussion about things. The following Christmas we had a meeting at the school and one of her teachers wanted her to see a psychiatrist, but I'd been to talk to her counsellor and things seemed to have settled down so I didn't want to disrupt her and I knew that the idea would really upset her.

She did her first year at sixth form but cut down her A levels because she was finding things too stressful. It wasn't clear why that was because she was a very bright child. Then, shortly after that she said that she definitely wanted to leave that school. I phoned the counsellor she was still seeing who said she thought it might be a good idea because she thought the school wasn't being very supportive; they were regarding Olivia as attention seeking. So I suggested to Olivia that she came home to the local sixth form college and she refused saying that she wanted to go to this other school that was near us. She'd heard good reports about it. So that's what she did.

She'd managed to avoid seeing Rory for most of the year by making excuses like "I am doing this" or "I'm going to the school to do a rehearsal." I phoned her up in the middle of term and to say that Rory had asked if she could go there for Christmas. She said to me "I don't want to see Daddy for Christmas. I don't like Christmas at his house but I'll visit him afterwards. I'll go for New Year. I'll write and tell him

or something.” She sounded calm to me on the phone, but, after this call the school found her crying in the corner. They took her off, had a very long talk with her and then phoned me up. I can’t remember the words they used, but they said they had a feeling there had been inappropriate behaviour and could I talk to her about her father? So the next time she was home I had a talk with her. I still don’t know the full story but that’s when she first said that he’d been abusing her since she was about twelve. This was as far as we could make out because I began to wonder about some of the incidents earlier on like the way she was screaming and screaming when she came back from the holiday with Rory when we were in India.

After Disclosure

The first thing I did was to ring up her counsellor from school who was really shocked. I think she felt betrayed because she had been trying really hard to support Olivia and had been putting out probes in regard to her relationship with Rory and Olivia completely denied any abuse at all.

In regard to my own feelings; the whole situation was very removed from anything I had ever contemplated or thought about, but I didn’t doubt the truth of it for a moment. For a start when Olivia normally told us stories about what was going on she would get quite hysterical and worked up, but when she told me this she was completely the opposite and terribly subdued. Also everything clicked and fell into place suddenly; the light went on. I also had this strong intuition that if Rory knew I knew he would want that knowledge completely wiped out. So, I had this bizarre fantasy that he was going to come to the house and kill me. I was picking up some very strong psychic current. Of course the whole thing put us in an incredibly difficult position with Ben as well.

The first thing that happened was that Olivia was suspended from the school. They said they wanted her to get proper psychiatric help before they took her back. I think it was unwise of them because what they didn’t see was that to Olivia it was like being punished for having revealed the abuse. I could see that her self esteem was completely shaken. It was awful; she had revealed this thing and she hadn’t realised

they would have to tell Rory so for her it was a massive shock. She had told this woman in confidence, but the school were legally obliged to report it.

The whole thing was such a shock, but emotionally I didn't feel much about Rory. I'd been through this whole process of losing any trust in him while we were in India and over this court case where he tried to force Olivia to fly back. I had gone dead in regard to him. It was shocking in regard to Olivia, but it was like there wasn't a relationship with Rory left for me to be angry about. There were episodes where my anger leaked out though. The strongest one was the very first Christmas after we learnt about this. We had spoken to Olivia's aunt; Rory's sister about because they were due to visit. She had been surprisingly supportive of Olivia at the time.

But then she went to the grandparent's home, for the family Christmas with Rory – the first Christmas after this had come out. His mother was distraught and refused to believe any of it. Olivia phoned them on Christmas Day and spoke to some of them and her Aunt said that she retracted anything she had previously said, that she didn't believe a word of it and that Olivia was inventing it all. She said she'd been on this long walk with Rory and he was really, really upset and distressed; he couldn't believe anyone would say this sort of thing and he loved Olivia so much and so on. Olivia came off the phone really, really upset because she wasn't being believed anymore. At that point I remember feeling absolutely livid with fury. I could just see Rory playing what I used to call his poor little boy act and going all weepy which he did when he used to get in trouble at work or when issues arose with his parents. He'd suddenly become very vulnerable and pathetic “The whole world is against me,” kind of thing. And I could just see him convincing his sister and his mother that Olivia was telling lies. I knew she wasn't. Basically all contact with us from his family was cut off from then on.

Court Case

The court case didn't succeed. As with the situation in India, Rory had hired very expensive London lawyers. My mum was present in the first day and said she thought the barrister employed by the Crown Prosecution Service was young and inexperienced unlike the barrister on Rory's side. His solicitors had been astute

enough to go to Olivia's school. They had twigged that the school must have more records than they had given before. Rory's lawyers had subpoenaed the school so that they had to come to court and argue there were no more records. So, the school then found further records from the pastoral care group and from the boarding house. The police officer dealing with us said he'd been down to the school and got the records but all he had been given was Olivia's basic file. At the time I was surprised that there weren't more records than that but I didn't think to query it. The court case was a fiasco because these records had been given to Rory's lawyers, Rory had seen them and the Crown Prosecution lawyers were completely unprepared and hadn't seen the material in time to use it as evidence whereas Rory's lawyers had had it for a while and were using it to prove that Olivia had been lying all along. They were saying "Look these records of Olivia show her not telling the truth right back to when she was thirteen. It's down here in black and white. She's lying about this as well."

The police officer involved said he was already worried a week before the court case by the fact that Rory's solicitors were planning to be very aggressive and cross question Olivia in a really unpleasant way. In the end they thought Olivia was too fragile for the case to go ahead. I didn't agree because I think Olivia had been through the worst of it by then. During the run up to the court case she had gone through a terrible, terrible state but by the morning it started she'd got herself keyed up to do it. I think that then being told it wasn't going ahead was the worst thing of all so it was a complete fiasco as far as we were concerned.

The whole thing felt like being frozen in time. In some ways it felt similar to when I got divorced or when Rory walked out. Then, with my immediate friends, like the mothers I met every day in the street I was very open. I thought, "Well, I've been married to Rory all these years and I always thought the fact that we've always had these quarrels, was my fault. But now, I see he is capable of walking out on two small children I don't think it's my fault at all". In that respect it was positive for my self esteem. But I noticed that when I had to go outside my little circle and meet Robert's friends I felt like I was no good because I had been divorced with small

children. That stigma of being divorced which I wasn't aware of in my own circle showed up as soon as I got outside it and then I felt really, really self conscious.

So again, in this situation people I knew around here were talking freely about it, and were terribly shocked and I did not notice it affecting my self esteem. However, when I was in psychotherapy training which I had just started I felt terribly self conscious and found it quite isolating having to tell people in the groups that this was what was happening to me. The feeling wasn't exactly shame, but if I couldn't really explain it properly I did feel it as a stigma. The worse thing was that people were unclear who the abuser was. I kept assuring people that I was living with Robert and not Rory when I talk about Olivia's abuse by her dad. Even so people hadn't necessarily taken it onboard like at and I'd suddenly find out they weren't clear that the person who abused her wasn't my partner.

Oriel and Myself, Over the Years

The situation had a curious effect on my relationship with Olivia. I was thinking that the only good thing to come of out it all was that she and I were close. First of all we got much closer because she got very, very dependent and reverted to being emotionally a child. She then moved from being very close to being very distant with me. That was quite a shock after her having being so dependent and close. She then got very involved with another older woman for about a year. That ended up disastrously because the other woman couldn't take the intensity and it ended with a massive row between them. She went through a phase of shutting me and Robert out completely from everything going on in her life, and now it feels like things have swung back to something a bit more normal now. However she doesn't feel she can cope with a job and doesn't know where she's going with her life.

Olivia survived and completed her degree but every now and then it would come to light she was still self-harming and making herself sick. I think her symptoms got much worse at university again because she had much more pressure on her. She got a first; I think she was absolutely determined to prove to her dad she could do well academically despite all the things he said in his letters about how mixed up and incompetent she was. She then started trying to do her MA but she realised that it

was too introspective for her. She left and has been living here since and is just doing some childcare. Unfortunately her first therapist left and emigrated to New Zealand. She's thinking of going there to visit her (Laughs). She's with another therapist and doing intensive four times a week therapy at the moment. She's gone off skiing today, even that is quite an effort for her because she won't want to go skiing and not be able to phone her therapist from wherever she is.

It was quite sad for me because when Olivia was really distressed and we were close I ended up not having much to do with the other children. We would get this division in the family where it was me and Olivia, and Robert and the other children. It had the most effect on Lizzie because she was the youngest when it all happened. All the children are fine now but I am curious to see what on earth will happen with Ben and Rory. Ben and Olivia get on quite well but they don't talk about this, it's a closed area.

As regards Robert and I, we still argue more when Olivia is around. It's usually to do with us bending over backwards to do something for her. We try to avoid confrontation with her because she gets upset and then we end up fighting with each other instead. This has lessened because Olivia is much more independent now, and manages to keep things mainly in her therapeutic relationship, but things are still changing.

Concluding Commentary

Talking to you has been more difficult than I realized it was going to be. I'd fantasized that I'd be able to focus on the more general difficulties of being a stepfamily. The aspect I really haven't touched much on, because perhaps I am still feeling protective about it, is the impact its all had on my relationship with Robert. It's quite hard to summarise but the general stress of the whole situation made me miserable then I'd feel quite vulnerable and dependent. In India I was very dependent on Robert in many ways for example I needed him to get the correspondence because the faxes all came to his office; but, it's very complicated to describe it.

A lot of the story is about how I wasn't in control and didn't know what was happening. The issues that made the abuse that took place possible are similar to what happens in other stepfamily situations. That's why I decided I was very interested in your work.

I started to tell you about Ben and the way discipline is difficult in a step family because there is all this other authority coming in. I listen to other parents, like my brother my brother and my friend's brother and their children; the oldest one now is fifteen or sixteen, and I feel amazed at the control they have over their children. Partly its because they are in France where apparently teenagers are treated differently in France. They expect that their children will do what they say and there is no question about it at least at that age. I think, "What?" because that's not how I experienced it. Because there was another influence, once they became teenagers there was never a certainty they would do what we said.

One thing that shocked me about talking to you is that I had so much to say about the year when he left. Because you said, "Start where you want," it seemed quite natural to start by explaining how it began. I don't talk about that an awful lot. I haven't even really talked about that with my current therapist. I end up far more often mentioning that my daughter's been sexually abused than the way Rory walked out and I was left as a single parent. It was a violence towards me and was more of a shock in a way than finding out about the abuse. It's interesting how it's still got the capacity to make me feel vulnerable talking about that. I judge myself; I should have been more aware of the cracks in the marriage rather than thinking that the problems we were having were just a blip. My inner voice says "Well Sally you should have realized things were seriously wrong" I suppose I'm wanting to protect myself against that shock of having had faith in Rory believing that he was really committed and wanted to sort things out

I saw my parents quarrel an awful lot in my teens and then they ended up quite close and fundamentally in a quite good relationship and so I always thought that when Rory and I were quarrelling it was just a process. However when I look at how my parents got together and their earlier married life I think it was actually a lot healthier

than my relationship with Rory. At the time though all I could see was that we were both in this relationship, were committed and so would sort it out. There was something more wrong with Rory than I realized because we don't just walk away from two small children like that and say you don't care about them otherwise.

So my vulnerability about the marriage break-up is something to do with me telling myself I was stupid or naïve in getting into that situation. Just about my whole world view has changed really because of it. I always knew Rory was quite inconsistent but it's only when you are outside of situation you can see certain aspects of it.

I used to meet other children's parents at the school gate down at the school and they'd casually refer to these awful problems they had when their children got back from visiting their dad and so on, and I would think, "Yes! These things happen all over the place; these sorts of..." I assumed Rory and I would be able to manage because on the surface we had had a very civilized marriage. There was nothing about his behaviour that I would ever have led me to imagine that the sexual abuse would have happened. Of course in retrospect I could trace back certain tendencies that I was aware of, like his saying anything to impress somebody whether it was true or not, but I assumed me and Rory could work together. When he left I comforted myself through thinking "Well, it's better than if he'd died because he is still there for the children to see and he can cooperate" but then six months later I was thinking "God, I wish he had died because it would be so much simpler, there wouldn't be all this stuff about visits and the children's reactions to the visits and having to communicate with someone you can't communicate with."

I was disappointed when I thought you mightn't interview me. When we met at the conference and you said you were researching stepfamilies I remember thinking, "my issue isn't about being a stepfamily it's about having a child who was sexually abused, and so maybe I am not relevant to your study?" and I was slightly self critical. But then I thought, "Actually I do have – a lot of issues, not just about the abuse, but all the ones before are to do with being a stepfamily and even the abuse itself is part of it really." It's relevant anyway to stepfamily situations because

research shows that with girls who were incest victims; sexually abused by their fathers, it's almost always the case that it happens when the mother is not able to protect them; either she is absent or is physically or mentally ill. So, there is a very strong protective function in having a mother present and active in the home with teenage girls. I wasn't there because it wasn't my home it was happening in.

Extracts from Analysed Transcripts

Clody - Death of a mother, how it was handled and subsequent consequences.

Clody's story brings forward several themes of interest in regard to this study. Firstly she talked about her feelings as a child in a stepfamily, providing a glimpse into how death and remarriage was treated in her family in 1959³³ when she was eleven. This demonstrates the impact on the child of not communicating with them about important events³⁴. Later in her own marriage she showed how her experience as a child was carried forward into her expectations of her own family. Finally she described how she is now talking with her sons and stepchildren so that processing and moving on is possible for all.

Clody's childhood situation illustrates the formation of a stepfamily at a time when a stepfamily was more likely to have come about following the death rather than the divorce of a husband or wife. (Robinson and Smith, 1993). It was usual that a bereft father would remarry so that there was someone to care for the children. In this case it was her mother's cousin – who had not previously married. From Clody's account the expectations seem to have been that she would automatically fill the place of Clody's mother; it was not possible for Clody to replace her mother in this way.

Mothers Death

It's a whole other terrible part of my story; it was really bad. It was really bad because nobody ever spoke about things like that. When my mother died people didn't mention her, nobody, nobody would talk about her.

³³ Clody was close to the same age as the fifty children born in 1958 studied by Gorell Barnes et al (1998) who grew up in stepfamilies.

³⁴ Gorell Barnes et al (1998) p93 – 98 (in the early 1960s) death had become a subject not to be spoken of, and from which children needed to be protected. There during that period no popular conception of the need to mourn.

I had big issues with my Dad about it and towards the end of his life he started to talk about it . Apparently he knew and the doctor knew she was dying and no one else. They didn't tell a single person, they didn't tell her. That's so terrible.

The fact that nobody talked to Clody or her brother Richard had an emotional impact that is still with her. The phrase 'children should be seen and not heard' comes to mind. Clody and her brother were given no opportunity to assimilate and grieve their mothers' death through talking. Her mother must have just vanished and it seems did not know that she was dying herself. The most painful thing for Clody was that nothing was passed on from her mother to her and the uncertainty.

(crying) I said to Richard (brother) 'I can't believe that she died and she didn't leave us a message'.

The way I feel about my children must have been the way she felt about us. And to not even know that you're going to die. If she would have known, would she have left us a note or something? There wasn't such a thing as a video in those days but I just felt cheated.

In these few lines the deep interdependence between mother and child is expressed. Clody moves between herself as a child then, talking to her brother about their loss, her experience now as a mother, her objective compassion for her mother not knowing of her own death, and the pain of her own not knowing. Her brother was her companion; the one person in the same situation as herself.

If Clody's mother had known she was dying would she have done something different? Within that question is hidden another dreadful almost unthinkable implication 'she mightn't have left a note anyway' and that might mean she didn't care? The missing message leaves room for an uncertainty that can never be answered and was a further abandonment (in that the living are abandoned by the dead) as Clody and her brother had nothing of their mother to carry into the future. She not only left but also passed on nothing of herself for her daughter to keep. Clody's feeling of being cheated is that of being deprived; deprived of her mother or something from or of her mother.

Without receiving a message or visual reminder of her mother it was difficult for Clody to process her death. This was compounded by the silence of her father and people who knew her. She and her brother did not have the opportunity of holding on to her through stories that might have provided a tangible sense of her existence.

Clody imagines her mother being like herself and feeling about Clody as Clody does about her own children. She recognises how important she is to her children and how important they are to her. She feels that given the choice she would never leave them without giving them something of herself.

The whole manner in which the adults around Clody and her brother dealt with this made impossible any processing of her mother's death in the form of grieving, stories, messages from her and so forth. I assume that she was just supposed to get on with things and act as if nothing had ever happened.

Its so important it makes me want to leave a video or something for my kids, although in some ways they know such a lot about me. They know how I feel because we do talk. But when you are 11 and 8 you don't.

She has determined to leave something of herself for her own children. A video will mean that they know her voice, her face, what she wanted them to know about her in contrast to her own mother who disappeared without a trace and in a conspiracy of silence. A video would mean that they could both see and hear her. They would have a visible reminder of her presence from beyond the grave.

*I felt cheated that nobody discussed her.
A couple of years ago I went to a few people that might have known her, who did know her and nobody could tell me anything.
But last week I thought of a woman who I've known since I was little and her kids are my age and she mentioned my Mum. I can go and see her any time she lives just down the road. When I see her again I'm going to ask her. But this is forty five years ago?
How much will she remember?*

In searching for adults who could talk about her mother now, Clody was expressing the hope that someone might hold the memories that she has longed for. Her mother was emotionally and physically immensely important for her and her absence left a hole. It was impossible to deal with that in a real way because she was supposed to act as if nothing had happened, her mother had just died and she and her brother were supposed to get on with it.

I remember having such a lovely time with her, she was just so lovely and beautiful and cared so much about us. It was just such a happy happy childhood until she died

.In the lack of anything concrete and without further discussion or talk about her, Clody's memory of her mother has crystallised into a golden memory of love and beauty.

Stepmother

My stepmother was Mum's cousin and she was our favourite Aunt. In her wedding picture she was a bridesmaid. Single woman, she was 40 and she'd had a lovely life. Well her mum and dad had died when she was very young and she'd been brought up by my Grandmother's sister.

Auntie Alice had been brought up by her own Aunt. In this story men aren't mentioned much. Knowing how death had been treated in Clody's immediate family I surmise that the circumstance of the death of Auntie Alice's mother was also something not talked about. Perhaps this is what enabled Clody to describe her life as 'lovely' a word that in its generality and lack of depth has the ring of a fairy story.

She came and lived with us for 6 months to see how it would pan out and then she and Dad got married just up the road from where we lived. We didn't go to the wedding. Mrs. G. said 'I met your dad and Alice in London in Whitechapel and they'd just been to Blooms. They said they'd just got married.

Not being invited to the wedding is another demonstration of how in Clody's family children were not involved in the stuff of adults. This happened even in situations that affected them deeply.

Anyway I've been really wicked in my life because I couldn't love her the same as I loved my mum. I went through stages of not loving her at all. I loved her for being Auntie Alice and she was a lovely grandma to the kids. It wasn't just that she wasn't my Mum but she stopped being Auntie Alice as well in a way. She stopped being that fun person who came to stay with us.

Clody was unable to replace her mother with Auntie Alice but somehow feels she should have done. I felt protective of Clody when she talked about her guilt and addressing this aspect of her said 'but she wasn't your mum'. It was then that Clody explained that she had lost Auntie Alice as well. Auntie Alice in her mother's place was very different from her as an exciting visitor.

My parents didn't have many friends and didn't socialise a lot so when people came to stay it was good fun. Auntie Alice would come in her little green car and she was always laughing. Of course at that time she was free as a bird because she didn't have a husband and she didn't have any children, so she would just come, whiz around and visit people, and go on glamorous holidays. She went to Italy and to France and that was lovely for her.

All that stopped really when she came and looked after us. It must have been so hard. Its not that she changed but her life changed because she'd got three bereft people to look after. How awful. My Dad's mum and sister (my grandma and my aunt) weren't nice to her, they were horrible to her. I remember them being really nasty and I didn't know what to do about that.

Auntie Alice's prior freedom seemed enviable, curtailed by the responsibility of a family. Clody here presented having a husband and children as a burden and seems to have felt responsible. Although she did not feel that Auntie Alice was her mother her description of wanting to do something about the hostility coming from her father's side of the family indicates a sense of loyalty.

Putting these two statements together we can see Clody's mixed emotions. Clody appreciated her presence but was doubly bereft, in that she had lost her mother and

her Aunt as she used to be. At the same time when faced with the world beyond her immediate household she was protective of her.

We always called her Auntie Alice except when I was referring to her and then I called her my mother and I introduced her as my mother. Aunty Alice always referred to me as her daughter.

In the way that she addressed her stepmother personally, Clody expressed her relationship with her.

Hearing that Auntie Alice called Clody her daughter I imagine the confusion that must have caused a child who could not feel the same towards her Aunt as towards her mother. The fact that Auntie Alice did this indicates an attempt for both to move automatically into the role of mother and daughter. The denial of her actual mother must have been very confusing and difficult for young Clody.

A further theme of the research appears here; levels of inclusion according to the boundary that is being described. In this instance there are two boundaries, the home and referring to people outside. Within the home Aunty Alice wasn't mother. For Clody to call her that in those circumstances would mean replacing her mother with her stepmother.

However, when faced with people from outside the household the different context brought into focus that her Aunt was in the place of a mother; Auntie Alice became Clody's mother as she was in mother's place. The idea of the outside is of people looking at the family and what the family chooses to show it seems likely that the family wished to appear to be intact. If Clody had called referred to her Aunt as 'stepmother' or 'Auntie Alice' she may have had to explain what had happened to her mother. No one else was acknowledging the death of Clody's mother and she would not have wanted to talk about it either.

The connection with the outside world also showed that there was a sense of loyalty between Clody and her stepmother. She describes being helpless and affected by the 'nastiness' of her Grandma and Aunt. She cared about and felt identified with her stepmother and wanted to feel that she was accepted.

I felt bad that I couldn't love her and I wanted things to be good for her but I wasn't able to do that.

Richard was much closer to her than me and I think that maybe that was because he younger and still little at 8. But I don't know, maybe he needed that mothering figure.

When a parent dies, the age and gender of their children has an impact on how they deal with it. At the age of 11 Clody was about to enter puberty which is a stage when girls develop their identity through rivalry with their mothers. (Robinson and Smith, p57). This rivalry might be exacerbated by the presence of a woman, not her mother being close to her father as she and her stepmother would be competing for his attention. Such a situation would certainly make it hard for her to be close to her stepmother during her adolescent years. This would be part of her natural development and as a girl this would not have been the case in the same way for her brother³⁵.

It could have been so much better but it could have been so much worse. I mean God it could have been anybody, it could have been someone ghastly that we didn't even know. At least we knew her and she knew the family. She was part of the family.

Clody was comforted by the fact that Auntie Alice was a biological relation rather than someone with no connection at all. Auntie Alice wasn't Mum, but she was family. The sense of familiarity, of someone known and who is connected by blood is significant in terms of what felt to Clody natural and manageable.

Clody's childhood was in many respects confusing. Important events weren't talked about i.e. the death of her mother and she was expected to accept new circumstances without question. This amounted to a denial of reality that made it impossible for her to grieve her mother and thereby adjust to her new situation. In Gestalt terms this is the time of digestion and assimilation.

³⁵ Although Clody's competitive relationship with her stepmother is surmised by me rather than described by her, we will later see that Clody felt jealous and competitive towards her own stepdaughter. This may have been an evocation of earlier feelings in a comparable situation.

Mary – Child raised from birth in stepfamily situation

Mary was in a slightly different situation to others that I interviewed. She is younger with three children, Grace, Katie and Ruby. Grace and Katie have now left home. She did not see her family as a stepfamily, however if her eldest daughter Grace has a different father than her siblings. Mary was pregnant with her when she got together with Jim, her current partner. Jim was present at Grace's birth and has raised him as his own.

I interviewed Mary because I was interested to see how the biological/step issues arose in a family where a child was raised from birth by her stepparent. I wondered whether she was in some way treated differently from the other children by Jim. What I discovered was that the issue of biology was important, but that this was more so between Grace and her father and her Mary. For Jim the fact that Grace had another biological father made his place with her insecure.

Mary, Jim and Howard

In common with other mothers I interviewed, Mary did things without much processing. She left her boyfriend Howard, moved home and started a new relationship without much thought. She did not expect to get pregnant.

I met Jim coming to visit my sister Janet. He was her mate in London and I used to come and stay.

I was living with Howard my boyfriend up North and I decided I wanted to move to London, so moved to London and sort of split up with him. We were both living with my parents; he was still living there, so we were still friends.

I met Jim, fancied him, sort of egged on by Janet, arranged meeting and things and invited him for tennis and stuff. We weren't really together.

Then Howard came to stay and I slept with him. We'd been together for four years and I'd never got pregnant. Slept with him that once when he came to stay for the weekend.

Looking back its quite bizarre really because we didn't really talk about it very much, just like I wanted to move to London and give up my job; just did it really. He never objected that much.

So when he came to stay it was just like as friends really; it was fine.

..... then a few weeks after that me and Jim got together and started having a relationship. So when I found out I was pregnant we'd been together a month I think.

I can remember just not being able to tell Jim because I knew it couldn't be his.

I knew it couldn't be his so it was really difficult to tell him.

I didn't know what his reaction would be. I imagined he'd probably want to split up and not be together. Its hard to remember but we stayed together anyway.

It was quite strange all through the pregnancy because I was always worried that he was staying with me because I was pregnant; that he would want to split up when I had the baby because it wasn't his. You know, all these loads and loads of different things.

But when she was born it was just like he immediately fell in love with her. It was like she was his from then on.

He was there at the birth, laughing his head off; very emotional.

For me, looking back it was like all the doubt went from then really.

We have talked about it and he's always felt completely in love with her and that she is his. He doesn't really think of her as not his kid.

The doubt in the relationship stemmed from her bearing someone else's child. If Jim hadn't loved her, then perhaps he would have disowning feelings. The language around children and parents is around ownership; they are mine, his, or not mine or his. And not mine implies some distance.

In terms of my query about Jim's relationship with Grace it was answered here; there seemed to be no issues between them about her parentage.

Telling Grace about her father

I asked Mary if she'd told Grace. It is a difficult thing to hide because father's are on the birth certificate; although I do not know who was registered as father on Grace's birth certificate.

Mary felt that Grace should know about her biological father. I didn't tell Grace (that she had another father) until she was twelve.

I always wished I had right from the very beginning, and the older she got the harder it got to tell her.

As far as she was concerned Jim was her dad; and so then to tell her she also had this other dad just seemed huge, because I didn't know how she'd react, I didn't know how she'd feel.

I always thought, "well if she'd know right from the very beginning then she'd of always known".

It went on for a few years; for a few years I just kept thinking "I've just got to tell her".

I remember I took her out to lunch or something, but kept her off school. I'd gone over so many times what I was going to say, and I can't quite remember what I did say, but I told her the story of me and Howard. How we were together for four years and then we split up and he came to visit. I think because she was twelve I felt I could explain it a bit more, I thought she might understand a bit more.

I didn't want to say "Jim's not your Dad" because that's just not true. So its like, "you've got a biological Dad as well" and explained it was his sperm.

One of the first things she said was "but Jim's my Dad" and I said "Yeah, of course he is, definitely".

Jim would have liked to have not told her. I think he was scared of how she might react and was very relieved that she still thought of him as her Dad. He thought that she might want to go off.

I told Mary that what struck me was that for all those years Mary was living with the knowledge of Grace's parentage. It was something that first she had to tell Jim and then she had to tell Grace, and she must have felt it was her job because she did it herself; she didn't do it with Jim.

She didn't want to meet Howard, but then after about a year or so she said that she would like to meet him. So we went to stay with my Dad and tried to get in touch with him. He was working away so she couldn't see him. And then after that she never wanted to. I still feel it would be good for her to meet Howard, even though she says she doesn't want to particularly. She said it would be really weird, it would be like meeting a stranger; but I do think that there's something there.

Every now and again I think I'll write to him. I did try and get in touch with him a couple of years ago, just to talk to him really.

He's now got a family, he's got three kids and a wife.

It would settle something for her I think to meet him.

Mary regretted not having dealt with the situation sooner or in a different way.

Looking back I think I should have always kept them in touch. It feels like that would have been the best thing to do.

Grace has always had pictures of Howard up somewhere, so she has always occasionally thought of him; must have done to always want that.

She looks quite like Howard. There's lots of things about her that are like him, which strikes me sometimes and not Jim, cause Jim didn't really know him.

Last time I tried to get in touch with him I spoke to his sister-in-law and she said she'd tell him. She came back and said he'd said "it's all water under the bridge, it's too late" that was to speak to me. That felt weird really. I suppose its not that weird after all this time.

I felt sad when Mary said that and told her. (This was an example of using my feelings to understand what the participant was feeling).

It feels sad. It would feel really sad if he felt that way with Grace, which I suppose in a way is what he is saying, but I don't know.

This is why I keep thinking I might just write to him. I mean he's never really tried to see her, he saw her a few times when she was little. I thought I might just write and tell him.

I would be really upset if she ever did try and get in touch with him and he wouldn't see her, and I'm sure she would be.

(In regard to Grace's sisters) Ruby only found out a little while ago, she had no idea. Katie's always known ever since Grace's known. But Ruby, because her understanding this is different anyway; its never come up.

Grace just mentioned it the other day, can't remember what she said. I think Ruby was talking about somebody having another Dad and Grace might have said "yeah I've got another dad" and Ruby was like "what? What do you mean?" and she says "I've got another dad" and something about being only really half sisters which freaked Ruby out. "No you're not, you're my sister". Grace talks about it quite freely and quite openly with people. I don't know why I think I should sort it out.

The way Grace is, I've often wondered if its something to do with Howard. I cant even describe what I mean by that, I'm not very good at this. She doesn't like to talk about emotional things really. I've always thought that I did do it wrong; that I should have done it differently. You know it's I would just hate it....

I interrupted Mary at this point so I don't know what she was going to say, but I think that her fear was that Howard might not want to see Grace if she approached him.

Maybe I should just let her get on with it. And if she wants to she'll get in touch with him, I don't know. But I still feel like I need to speak to him or something.

These anxieties were not something Mary had felt she could share with Jim, although she had done with her sister and friends.

However she was alone with the dilemma.

It all comes back to me really doesn't it. I know one friend has said she really thinks I should, she really thinks it would be good for Grace, it would mean something. So I suppose that also made me think I should do something about it. What do you think?

Here Mary was asking me for my opinion and support. I felt unable to give her a full answer. The truth was that I didn't know, but writing here, I trust that her motherly instinct was correct, that she had a sense of Grace and what Grace needed.

One of the things that held Mary back was her wish not to exaggerate the relevance of the situation.

I've never wanted to make a bit deal of it. Like if she'd always known that would never have been a big thing.

I was reminded of how adopted children often want to meet their parents. I asked Mary if she thought that Jim might fear that if Grace met her Dad he would lose her. Less security than if he was her only father.

Yeah I think he has felt those sort of feelings. I know probably they're the kind of feelings he had when we were going to tell her. It's good to talk about it. I sometimes think about it not as a whole thing. It's quite nice to talk about it all.

In some ways I found this the hardest interview to do. I know Mary but in a very different context and found myself inhibited in showing the researcher/therapist side of me. On her part, Mary found it hard to talk about emotional things, she said that she always had done.

However, I felt that what she had to tell me was valuable. I could see again how mothers often seem to be at the centre with their children, holding responsibility, aware of their feelings and thinking about how to do things for the best for them.

Also, how fearful it is for a parent to know that someone else might have an emotional claim on their child.

I become curious to think "what makes someone a parent?" I have assumed that parentage is biological, but within Mary's frame it isn't that. There is something about the level of inclusion and love that Jim felt for Grace that made him her father. He was more than a stepfather, he didn't just "step" into a role, she became part of him and he of her; it was a psychological process.

APPENDIX I I – PROJECT DESIGN AND DOCUMENTS

Original Design From Learning Agreement

Aims and Objectives

The aims of this project will be:

- * To make a contribution to the understanding of stepfamily issues
- * To explore the possible connection between physical/biological and emotional dynamic structures in stepfamilies as identified in my PEP
- * to increase empathy among psychotherapists who don't have much – or any – personal experience of stepfamilies
- * To develop support for stepfamily members through my own work and with other therapists
- * To bring forward the awareness of issues brought about by stepfamily situations among humanistic practitioners.
- * To provide a window into the lived world of mothers in stepfamilies and engage the reader/participant in the process (Asherson Bartram, 2006, p11)

Overview of Methodology

- * I will record and transcribe the interviews before writing up and will at all stages of writing go back to my co-researchers to make sure that I am accurately representing their narrative.
- * I will listen carefully to transcripts from earlier Focus Groups to extract the stories of stepfamily mothers.
- * I will make Biograms and Genograms of participants families which will provide a visible representation of co-researchers' family relationships.
- * I will write a journal (Etherington, 2004 p133) in which I record my thoughts, feelings, connections, dreams (since embarking on this doctorate I have at times had dreams that directly relate to my process).

- * I will remain in psychotherapy in order to process the emotional impact of the research, keep me on track with my doctorate journey and as a resource for my personal reflection.
- * The combination of transcribed interviews, Biograms/Genograms and my reflexive commentary of the process will provide the data of the research (Asherson Bartram, 2006, p22)

Outcomes of the Research

- i) Final project to include narratives of stepfamily mothers, discussion of links between physical/biological structures and emotional dynamics in stepfamilies, reflexive account of research process.
- ii) Groups for stepfamily members
- iii) Workshops for humanistic psychotherapists aimed at building empathy for and understanding of stepfamily members
- iv) A contribution to the Gestalt and humanistic family theory in regard to mothers' identity in stepfamilies
- v) Articles published in psychotherapy journals aimed at raising awareness among humanistic psychotherapists and counsellors on stepfamily and parenting issues as well as on my website. (www.gestaltworks.co.uk)

The document that I deliver to the University and Metanoia Institute will describe the process of the work with an ongoing reflective commentary. It will include the narratives of my co-researchers, analysis of their family structures in regard to their stories, the account of my personal journey through the research process, the findings of the research and the different influences and a critique of the overall project. Thus it will combine narrative and theory (Asherson Bartram, 2006, p28).

Extract from Transcript of Focus Group

Note: This is part of a 3 hour meeting.

C: Let's get closer if it might just be us – and even if it isn't. 18 people were expressed an interest and other people said that they can't come today but that they'd like to come so, even if it is just us

I: I'm sure the fact that the FA cup final is on didn't do you any favours.

C: It mightn't have done actually, I didn't realise about it. I thought that we'd start about what interested you to come really. Hang on .. I've got a prop, because I want to just start properly. *Brings out a bit of paper.*

I'll tell you first of all a bit about me, because you don't know me. I'm a psychotherapist and supervisor, Gestalt trained and I'm doing a doctorate at Metanoia, and I've been working and looking and thinking about stepfamilies for a long time, because of my own family which I found really hard. And myself and my husband, we each have children but not with each other. And my children ... I've got a boy and a girl and they lived with me and then his son moved in with us and it was really hard. I was surprised how hard it was. But while I was doing my therapy training I started to do some volunteer work for National Stepfamily Association on their phone line and discovered that lots and lots of people feel the same way. Then I thought that what was really useful for me and helped me was actually my therapy training because I got a chance to think about what was going on and talk about what I was feeling about it all. So I tried to set up um some sort of therapy stuff for stepparents and I got a group going for a year but it was sort of hard work to get it going and then it stopped. Like I talked to people and lots of people would be interested, but to actually get people to hear was harder. So a few years on I'm doing a doctorate and it just seemed to me that of all the things I've been involved in this is really important, its really current,

I: There isn't that much material out there either.

C: No there's not, there isn't. A lot of it as well is quite sort of academic and hard to follow and stuff like that.

I: & R: Mmm

C: So really where I am and what I'm wanting to do ultimately is to do this group today but also to do more and to get something ongoing where we sort

of think together about what useful ways of dealing things and ... I don't know if you read the cooperative inquiry thing I sent, but this is a way of working together so that we all think and we all try things out and bring it back and it's a process. I would really like to work that way myself. And I think that's something that develops, we can't sort of plan it and it would mean me being less of a group leader and more with everyone. I'm imagining like I would support that because I've got to do work for my doctorate by writing notes (*doorbell rings*) I'm going to answer that.

C goes out of the room.

C: Anyway so I suppose that's the background of my interest and I've done a small project which I sent you a bit of, which was based on interviews with people. And in fact some of what came of that I'd like to look at a little bit with us today. And um I suppose the only thing I was thinking was just to sort of set a basis because I don't want us to just assume things so I want to say, that I want us to be free to talk about things that may feel difficult and that therefore we have an agreement of confidentiality between us that those things aren't talked about outside in a recognisable way so that anyone could identify anyone from this group. I don't know if you want to add to that, but that's my thinking.

And the other thing that I wanted to say is that I'm really interested in people's reactions to their experience and also what its like here, and so as much as possible for us to bring that as well, if something feels good or difficult or uncomfortable then to say that. The other one was to just, I was thinking to nurture a culture of query, so that if we are interested in something that someone says, or don't fully understand, or want to know more, to come forward and ask the questions for us all to do that, not for it just to be something I do. Yes.

And the first thing I was thinking was just to go round and do names again and say something about why you are here, what interested you to come here, and what you might want. Um yes, I've said what I

Cl: Where did you find us all? I was out on the Stepfamilies website, so I'm curious Ch that you worked together at the Stepfamilies Association. Is that your entry point to this group?

B: Um no, I think over the years Claire and I have become friends, but we started off um at Stepfamily; I trained Claire in stepfamily issues. We then went on and co-wrote a book together about stepfamilies um.. for people in stepfamilies. Umm and I'm a psychotherapist in private practice so that

stepfamily issues are always within the work that I do. Claire and I originally had intended to do the PhD jointly together, um and I had to back out so you know, my interest is already hooked in to what Claire's doing. That's really how I'm here.

- D: I'll say a bit about me. I'm Claire and I are very old friends, we met at school in 1960 something or another when we were 15 and I was saying to I, we, our lives have followed quite a strange parallel in ways, we ended up going to college as mature students around the same time, living in the West Country around the same time, then doing different psychotherapy trainings around the same times. I'm a psychotherapist, but I'm not directly involved in stepparenting sort of associations or anything like that, not officially anyway, but ever since Claire started doing this doctorate, I started having conversations more about the stepparenting sort of issues and I was realising how I am a stepparent in many more ways than I actually realised. Its like the light suddenly came on, and yes, there's a whole load of associations and connections that I know have, things I've never thought about and considered, um so I'm sort of waking up to the whole issue, even though I've been aware of it, it seems like there's another level of awareness sort of creeping in. So that's me, that's my connection. So we've had informal conversations but I haven't actually been formally involved like this.
- I: I um got involved with R: and I he has two children and I have a daughter and suddenly having to confront stepfamily issues that, although I myself have stepfamily issues because my parents are divorced and both in new relationships it never occurred to me that they were stepfamily issues until I myself became part of my own stepfamily and um and so ya it is very much an ongoing process of learning and discovery. And I saw, happened to see Claire's little ad in Time Out magazine very soon after starting to live with Robin offering, advertising a support group and I thought 'that would be good' and I cut it out and never did anything about it and by the time I finally phoned her (laughing) which was quite a long time, I think I was cleaning up to move house or something, and I had this piece of paper and I thought let me phone it up you know, and um the support group at that stage wasn't running but Claire took my details and contacted me when this group was coming together to see if I was interested. Yes. I'm very interested in exploring everything to do with stepfamilies, because there are so many issues that um arise out of that dynamic.
- D: I don't want to start asking question, but part of me really does. Like I was thinking well, what I'd really like to know is in what way are we in stepfamilies. Not ask yet, because I realise that people sort of um

- C: I didn't know how many people there were going to be so I put on my list of how to do it, first of all just to say why you're here and then to go round again with that.
- E: I'm just curious how did you get us all?
- C: All from different places. Ooh, I'm going backwards a bit. There are others who aren't here who said they were interested and I would like to send them notes of this group because they will probably come to the next one. Well one person will definitely come to the next one and I wanted to ask you how you felt about that.
- D: Not a problem
- C: Thank you, sorry to go backwards but I had forgotten about that.
- B: Do you mean identifiable?
- C: No - just sort of R: anonymous C: yeah they'll be anonymous but they'll also be the same as I send you which will be you, I'm wanting to get themes from today really, and also to know if people want to carry on, but I want to get themes, so it's not really going to be the detail of what happened and its um ... and I'm happy to send them round to you all first, with a note saying 'are you OK with me to send this on, before I send them on'.
- ALL 'yes' 'I'd appreciate that' 'sounds good'
- C: Thank you
- R: I didn't say why I was here, its probably obvious um... I said she was coming and ur it was a bit hectic during the week, was I going to come and I said 'don't ask me at the moment', things were quite quiet today so I said that I'd like to.
- C: You're not a football fan
- R: No, I'm here because I'd like to be. Life is hectic but err ... fortunately its reasonably calm today.
- C: Cos I was thinking how old are your children? And I'll tell you how old mine are, they've all left home.
- E: Does it help that they've all left home? The issues still continue don't they
- I: It doesn't help that they're older you know, it's just different, because I have that, I have the situation where my mother's home doesn't feel like my home.

It's very hard for me you know, because no matter how much it is my mother's home, there is the man that she lives with who is not my father, and so I very much on the one hand the stepmother issues, and grappling how to relate to his kids and whatever, on the other hand understanding so much where they're coming from because I myself have issues of non-acceptance both of the stepparent and you know feeling that the stepparent is not accepting me. You know, that's a very interesting one for me to see that from both ends.

E: That ties into um my experience and that's one of my motivators for being here. I grew up in a stepfamily situation which was I feel very damaging, very dysfunctional and therefore that has very much set up belief systems and value systems about my own personal life choices and I now find myself in a stepfamily, but I've chosen to be in a stepfamily situation um and other motivators to being here is I feel in many ways I've kind of taken a very um work approach to this in terms of .. to get information, I'm going to um look at behaviour, I'm going to you know try and get insight and change my behaviour, its all been very um you know, there's been that approach so I many ways my feeling is that I've done the things I know how to do but um clearly I don't have all the answers so there's value in learning to do things differently from what I do, what I am doing although I see there are benefits, it doesn't um tick all the boxes and there's still issues and difficulties. And whilst I don't think that new learning will factor out all the difficulties evermore, I suppose I'm looking for coping skills and you know, this kind of, the action research thing, the structure of the group and how its planned will be to produce skills as well as that kind of support and sharing. And then on the back of that um I'm doing my own research project, its ur unrelated my research but um just that I think will be useful just in terms of your processes that I can borrow (laughs).

C: What is your research project?

E: To do with housing so community development and um housing legislation supporting people.

C: And I found you on the internet didn't I. I posted a thing on a website called 'Stepfamilies UK' and I got quite a lot of response. People who said they were interested, but um I mean err one person is someone who really apologised for not coming and is giving me dates that she can come to another group, so she's really interested and somebody else said they couldn't come.

- E: I think that's quite curious in the sense that although you will create an identity in terms of being there in terms of the flesh, that if you are on that internet site that to come to a group, your anonymity will change and so I wondered how many people would be up for that.
- C: Yeah – but I was clear, but more people offered to um talk to me, to answer a questionnaire or something like that, which may also be useful. So I think that perhaps that's something a group could do, to think what questions, or how would we like to approach people who didn't want to be in the group but who have got something to contribute even without meeting up. Or maybe that's too much I don't know but its just a thought that I had. I might be in danger of spreading too wide.
- E: Mmmmmm How much time have you got?
- C: As long as it takes really. Well I want something to get going whatever, but I have to write an accompanying document of 70,000 words to describe the process and what the outcomes are, the research background and the difficulties, ethics and that's what I have to do alongside of anything that we might generate.
- R: Our children are, my daughter is 9 and his two are 14 and nearly 13. 14 year old daughter who's had a lot of difficulty over the past 3 or 4 years and my son who is 13 this summer who is, different and sort of sailing through it.
- C: How long have you been together?
- R: Nearly 4 years.
- C: I ran into difficulties with my son and my stepson, who were a year apart; and my son got very upset and is still really upset. I got together with my husband when he was 8, well it was difficult and now it's become impossible, he won't talk to him. He won't talk to me either because I live with him, but he's 25 so that's what's happened to us. But I think there may be other factors that have caused that other than our relationship.
- I: Is he in contact with his biological father?
- C: Just about, um but his father is flaky. Laugh
- I: Yes we have that as well, my daughter's father is. ... she hasn't seen him for 6 years and he's completely unavailable and not in contact and .. very difficult for her, the feeling of this absent father.

- E: As the result of coming into my relationship now with my partner which is three years, and the children are 7 and 2 ½ and when my partner left his former relationships, his partner was 7 months pregnant and I mentioned previously my um history, I haven't seen my father for 20 years and on the back of seeing my partner struggle to maintain a relationship um in the face of the animosity of the birth mother and what I see as her .. this is a completely value judgement, corrupting behaviours, I just thought that well, all the things that I have taken on board and had questions I think in some way but very much in the context of somebody else's idea, my mother's history of how her explanation of my father and um that opportunity of my partner gave me another perspective, so after 20 years I um found my father 3 streets from where I'd left him so and that relationship is um I can't say restored, but the lines of communication are now open, but you cannot get back 20 years. So that's one of the drivers to you know, it has to work and things that I, you know, that are hard that I have to do for my own stuff, in my mind the whole thing is the children have **got** to have their dad. So we've got to put up with all this crap physically because they've got to have a dad.
- I: Ya that's something that I'm very keen to explore, because more and more we're becoming aware of the effects on R's children of the negativity of their mother and how damaging it has been and is, particularly for his daughter and um and it would be great if we could walk away from this with some idea of how to improve that for the children you know.
- R: I always aim to be very supportive of their mother. My kids are with their mother and my daughter did come and live with us stroke me, because I spent a lot of time with her very ill father recently, for 3 months and um .. she was fed up ... I wasn't able to provide the level of nurture she was getting .. physical nurture because I had lot of work on and things like that and I wasn't there for some of time, so the actual physical nurture I wasn't able to provide.
- C: You mean cuddling?
- R: No, I mean actually providing food and that sort of thing.
- C: Oh right.
- R: and giving her lifts here there and everywhere. She did want to be independent and do her own thing so ...
- I: The way that her mother is with a child is not something that anyone else can be. I can never be with his daughter the way her mother is with her. You know, it's just a different dynamic and different relationship, so it was

difficult for her, you know the daughter to come and live with us and suddenly find that she wasn't getting all the attention that she got from her you know mother. And it's not that you know I like his children very much um, I love them I don't have problems with them.

- E: There are layers because the parenting task I believe is the parenting task. And yes you in your role and personality might bring things into it, but um you know spag bol, beans on toast, you know lift to gym, is its own action, it's not um .. I don't feel that the children's birth mother has exclusive you know monopoly on that skill set, but to intimate the emotional dynamic that's happening or interaction that underpins that. What will be different is that...
- I: Well no the issues that we've had were things like she didn't like the food I make. You know it's not the same as the food her mother made. I've been a vegetarian for 20 years when they're father met me he became a vegetarian, so suddenly he started eating differently, so that they would come to his house and I'd changed him. And for his daughter that has been terrible. It's really been some issues she's been furious about.
- Cl: Has she?
- I: How dare he change, how dare he become different, so she comes to our house and the food that we eat is not the same as the food that she eats at her mother's. The food that I prepare is no the same as the food her mother prepares and she doesn't like my food you know.
- R: Having said that when she first moved in you know she was very happy to go along with you, I think it was just you know that I wasn't able to get it together
- I: Yah
- R: Four days after – was it four days, or just after week when she came to live with me, her Mum said 'I can't cope any more, I'll have a nervous breakdown if she doesn't come and live with you'. So there was that, it wasn't yeah: It wasn't her choice (I talking over) she thought she was being thrown out of home by mother so that wasn't particularly good, and then a week later I realised that she urgently had to go to SA to be with her father who was very ill, so I was left with M I's daughter and her daddy and we were fine
- C: A week after she moved in? How terrible!

R: A week after she moved in and then at the end of that week I had to go away on business for two days overnight so, my daughter then had to go back to her Mum's because there was nowhere else for her to go it was not appropriate to leave a 14 year old on her own, also a very disturbed 14 year old. So that really, it was a very challenging time. These things happen. So it wasn't like when she came to live with us I was so happy and the circumstances weren't ideal, that's why she came but

E: Did you feel like you'd got her back, that it was what you secretly wanted?

R: My feeling is that she and I are very very similar, the way we work we communicate on the same level and her mother and I, she and her mother the communication wasn't quite there, but because she'd been living with her mother there was this sort of wrench, that I'm the sort of absent father that's not seen that often although she and I are very very similar.

E: You're non resident

R: Non resident yes.

E: That's so loaded

R: And her mother his apparently this is what I: was saying, still puts a lot of negativity our way. I aim to be supportive. I actually phoned my ex-father in law today because it was his birthday and I had a nice chat with him and my ex- mother in law so, I aim to try and keep things as friendly as possible and not animosity. Occasionally one gets a bit stressed and might say things that aren't ideal.

E: It was interesting in the notes this idea about the identity of the children being part of us. We are trying for a baby at the moment so I don't have biological children of my own yet. And then again even "my own". So I say that, I immediately think well that's the possession bit (mm mm) of ourselves and um again partially as a woman and having lived in the world and all the rest of it I can think in terms of the biological mother while you know, when the relationship ends your always hurt anger, you know all the rest of it and then somebody that you don't know, you don't choose you know, bathing your children and um feeding them chicken, she's vegetarian. However, the children have been you know, brought up eating meat, but with the baby um the first two years, 2 ½ now we followed the non meat deal, because that's what she had said you know, it's the same washing powder, the same routine after school, although part of me is very resentful of that, you know I got myself through college, brought my own property and decided you know I was unmarried and not had children at 32 for reasons.

You know, so to have my life completely in somebody else's value set is very annoying. I'm amazed to some extent very annoying.

So I you know, that kind of, you know that children as extension of ourselves and our mind set and that that kind of I don't know I think for us there's so much conflict in terms of our roles and status, whose got control, whose got power over what issue, where is it located you know, it's our home but she thinks its her family in my home and its now not just my home, it's the home of everybody. So if we don't have a two tier stepfamily which is what I lived in where I didn't feel home was my home and I certainly don't want to have that negative experience, bring that to another generation. So we're here, its just too hard.

C: It sounds similar to I that your home isn't your home

I: But mines different because my parents split up when I was an adult, when I was 22 years old.

C: But it still feels like that.

I: But it still feels like that. It still feels when I go to my mother that I don't you know, have to be on my best behaviour and be careful what I say in case my stepfather gets offended because he's very different to us culturally. We're Jewish and he's protestant. The two cultures are just so unbelievably different (voice louder) he's English protestant and we're you know (laugh) its amazing you know, I'll say something that is not at all intended to be insulting, really isn't and for him it will be a major he'll really take offence, so I'm constantly having to tread lightly around him in case I say something offensive. You know, that he finds offensive. And that's not a relaxing thing in my mother's home.

D: I think, you know the thing that interests me um and I think it's from my own experience and also from talking to people is the envy factor, is the way that the biological children are so envied and things get played out through the biological children. You know I think, it's almost are lots of power issues, but it's the way that often what's unresolved in the relationships that are broken then get played out through the children, and it always seems to be around envy.

E: Shields and the weapon. Its over you know, it didn't work and that is very sad. And you have all this power and prestige and status as their biological mother and yet you would use these children to suit your own agenda, and it society says 'well poor you' you know, she's a Trollope, he's a bastard, you know you're left with this child, it's all so awful, and it's us dragging the

children from the car screaming and all sorts of other crimes that she's committed.

- I: R's daughter started self-harming. (That's a tough one). You know this has been going on for years and you know R didn't, so you know both parents were too scared to address it, she was refusing to get any help because of her mother's initial um pushing her into circumstances that she didn't feel comfortable in, and um basically because of a threat of social services early on in the whole thing, everyone's been in kind of denial about it and this child has been cutting herself for 3 ½ years already you know and this is the... I came up with the theory just in the last couple of days that this is to do with somehow the negativity that she is getting from her mother that she is.... The negativity against him, that it's been so painful for her because she loves her father so much and there's such a strong bond between them, and it's from the beginning the mother's just been giving her so much negativity about him that she's
- E: Well who do you choose?
- I: That's it well she's just .. the suffering is just unbelievable you know, and it's getting worse and worse and worse because it's not being addressed. She won't let anybody address it you know and now it's got to the point where she refuses help you know.
- R: She just walks all over her mother
- C: I'll tell you something just from my own experience with my son, that until a child is 16 you can get them to do things they don't want to do, but once they're 16 you can't.
- I: So we haven't got much
- C: If you really want to if you really think intervening is important, at the moment you can
- I: She's a typical 14 years old; she's very um grown up
- C: But I'm just talking about that law, I mean that is the law. Because I had difficulty with my um, the stuff with my son has been going on for a long long time, and we also didn't really even realise there was something to be addressed actually until he was too old and then I got in touch with somebody I know who's a psychiatrist and I was frightened about what was going on with him, and he said 'well there's nothing you can do actually, unless he's willing because he's over this age. So that's actually the way that

it is legally. At the moment she's under care and control of the adults round her but over 16, there are actually less services around for children who are sort of not children any more, 17 – 18 year olds, it's harder to find stuff. I know that's a sort of warning.

- R: We tried so many different things, she went to see a counsellor to start with and that was no good, it wasn't working, she went to see a psychologist, that didn't work, her mother took her to see a psychiatrist which I said 'no don't do that if she doesn't want to do it' and then she went to see a few alternative therapists which seemed to be working a little better but now she's not interested in that. Really she's um..
- C: Well you see a family's a whole system and I think that's what's difficult, I'm thinking aah – keeping my psychotherapy out, what is difficulty sorry
- E: I'm a trained psychiatric nurse and I'm thinking professionally well, just emotionally, it's not exclusive
- C: But it's just that she's representing something in the family. It's like there's a difficulty in the whole family but she's the one that's coming out with it. So in a way getting her to see someone, you're still saying it's you, it's you, it's you, but it's not, it's actually all of you and maybe a way forward would be to find a way where you're all involved and at least acknowledged it so at least she doesn't feel there's something wrong with me. I mean often when I talk to adults I find myself saying to them, well actually there's nothing wrong with you, you are having a perfectly normal response to a very difficult situation, but it looks sort of ... and in a way she is, she's drawing attention to something.
- I: Sure, something that's deeply disturbing for her. Of course
- E: I mean you said about the mother's negativity, birth mum, really echoes with me, and part of me wanting to be here as well is also about that um when we were talking about a whole system, a whole family, it isn't just this person, and I want to develop my insights so I can change or adapt my attitudes or behaviours. Because it's not just her, everything that she does I'm doing. You know, she's not acting in isolation, and even though I have spent three years heaping bile upon this woman who I have this really unhealthy hatred for, that's not only to role that back and unpack it because it's not the whole story, because in there is so much of my stuff, to do with you know, my mother, my stepfather, you know, even anger at my father, why did you have children with someone whom you don't even love? What were you doing?

You know I waited, waited, waited and there you go you, just. Oh, its hardly populating the world....

- I: The insight from your own experience to have the wisdom to hold back you know.
- E: In that direction, to others totally not, or the sticking point of some insight, no action (laugh)
- I: Wouldn't it be great if everybody in the world had the understanding to wait to have their children with the right partner so that we didn't have all these issues.
- E: So what happens when you think it is the right partner and it still doesn't work, because that happens too you know.
- C: Well people are young. I mean I was 22 when I had my children. I had no idea why but I met this guy and I wanted to marry him, and I clearly wanted to have children, I got pregnant pretty quickly, but I wasn't very mature.
- D: I made what one could describe as a terrible fatal mistake when I was much older because I um, I did have a certain amount of wisdom, a lot of experience etc. because in my situation I had my son when I was 28, I wasn't married to his father, we lived together and when he was 2 we separated and in the meantime I was a single parent for a long time, I had other relationships and then in the middle of all of this I also got remarried. Well not remarried, married when I was 40. When I met my husband, um my son was 11 (I'm trying to get the chronological bit right) so, we were in love and he comes into our family, and there's now 3 of us and for the first month it was fantastic and brilliant, and then just shortly before we got married this guy who was loving, and open and warm and tolerant and all the rest of it, became the antithesis of everything he had been. He became cold and intolerant and very nasty to my son, very nasty, very jealous and it all started.. he just one day lashed out at him physically and just out of the blue. And no warning, nothing. And I was so shocked by the change in his character and his behaviour that I, I was sort of thinking well, there's got to be, the person that I married has got to be there somewhere in all of this, he can't just have completely turned into someone else; however um his hostility towards my son just increased and what happened was that during this time my son was by now 12, 13, he got mugged twice in a very short space of time, he started to get very socially phobic, very frightened of going outside. But it wasn't just that, because when I think about our relationship, it was also that there was this awful hostile feeling in the house as well as

outside of the house. My feeling is always that everything, his phobia was also to do with the horrible feelings inside our family, you know, that had to be expressed somewhere. And to this day, he's now nearly 23 he's still suffering from the same sorts of phobias. He's a bit better, but he's still suffering, and it's still very hard to get him to go out and socialise and to go, you know, to go places, because of this feeling that something terrible is going to happen.

Documents Relating to Research

i) Recruiting Participants

Stepfamily Research

Narratives of Mothers in Stepfamily Situations

I am undertaking a doctorate research project at Metanoia Institute and am looking for people to take part in my research on stepfamily mothers. I am intending to write on stepfamily dynamics through mothers' experiences.

I would like to talk to mothers who brought up their own children in a stepfamily situation, and whose children are now grown up.

I would also like to hear from other mothers and stepmothers who would like to be involved at a later stage of the work.

Involvement would mean an initial meeting with me, followed by an interview, where I will be working with participants to make sense of their experiences as a mother in a stepfamily. This may take place over one or several sessions.

The interviews will be transcribed and discussed in my doctorate project. I will also be collecting material for a future book. Identities will be protected throughout and I will discuss this fully with participants.

If you would like to take part, know of someone who may be interested, or could suggest to me places to look for participants, please contact me.

Claire Asherson Bartram

020 8361 6146

clairebartram@blueyonder.co.uk

ii) Pre-Interview Meeting

Narratives of Mothers in Stepfamily Situations

Dear

Thank you for your interest in taking part in my research. This is a note that describes what we will discuss in our meeting in regard to your possible involvement in my research project.

While I hope that you would find your involvement beneficial, there is also the potential for difficult feelings to be stirred up through talking about your family in-depth. I would therefore like to talk through with you what you might fear in this regard, and what support you might have should this be the case.

I want to get in touch with your experience as a mother – so this will be my focus. It will be an open interview in that I don't have set questions. I intend to follow you and clarify your thoughts so that what is important for you emerges from our conversation and as far as possible I get a felt sense of your experience.

It will be impossible to talk about this without mentioning other family members. You can be assured that in transcripts and writing up names will be changed and identifying circumstances where necessary. Your involvement may have an impact on your family and you might want to think about how they might feel about it and possibly discussing that you are doing this with them.

I can offer some confidential time with me after the interview to talk through the experience of being interviewed and look at things that have arisen – this would not be recorded.

I would like to know any of your concerns about this.

With regards

Claire Asherson Bartram

iii) Interview Release Form - Letter of Agreement

Narratives of Mothers in Stepfamily Situations

I have met with Claire Asherson Bartram and agree to take part in her research on stepfamily dynamics. I understand that this involves taking part in an in depth enquiry into my experience as a mother in a stepfamily.

To this end I give permission to be interviewed by Claire Asherson Bartram and for this to be taped and transcribed for this to be used in the final document and a future book. I understand that my name, the name of my family members and other identifying details will be changed and that I will be consulted about this at the relevant time.

Following my involvement, should I so wish, I can have a confidential meeting with Claire to discuss anything that has arisen for me personally as a result of the research process. I am also am free to discuss my thoughts and feelings about the research throughout the process.

The transcript from the interview will be returned to me for accuracy checking and for any extra comments that I may wish to append. I will be shown any writing that involves my input for my agreement that it is an accurate reflection and in order to ensure my continued consent. In this regard my wishes will be respected and I understand that I am free to withdraw from the study at any time.

Signed date

iv) Approval of Transcript

Dear

Narratives of Mothers in Stepfamily Situations

Thank you for taking part in my research project and letting me interview you. I hope that you found it a useful experience. I am continuing with my research and will keep you in touch with developments.

I enclose the transcript of our conversation. Please read it, checking for accuracy and also if there is anything you might want to add or would like to talk about further. You can return a marked copy in the enclosed SAE. If you want a copy for yourself I will send one out to you or email you a copy; let me know. Also, please give me some alternative names for you and your family.

It's possible I will want to talk to you more but won't know about that till a later date when I start writing things up. In the meantime do contact me if there is anything connected with this that you would like to discuss or if on you have other things you would like to tell me.

Best wishes

Claire Asherson Bartram

APPENDIX III – INFLUENTIAL BOOKS, SEMINARS AND PEOPLE

Women’s Ways of Knowing – Separate and Connected Knowing

‘Women’s Ways of Knowing’ presents the collaborative research of four women; psychologists interested in human development (Belenky, Clinchy et al., 1986). The observation that inspired their research was that ‘women often feel alienated in academic settings and experience formal education as either peripheral or irrelevant to their central interests and development’ (p4). Research took the form of interviews with a hundred and thirty five women in America from a variety of educational institutions.

Belenky et al. described women’s ways of knowing as having been sidelined because until the time of their writing – more than two years ago - education had been male dominated. The result was that attributes traditionally associated with the masculine such as objectivity and logical thinking were promoted while those associated with the feminine such as empathy and flexibility tended to be ignored (p6).

Thus the researchers argued that knowledge - in the way it is acquired and type of knowledge sought - has a gendered bias towards what is most commonly valued and learnt by men, rather than types of knowledge that are more connected with women and mothering. The original book was followed ten years later by another titled ‘Knowledge, Difference and Power, Essays inspired by Women’s Ways of Knowing’ (Goldberger, Tarule et al., 1996) which provides critique and further thinking on this subject. Their writing speaks to my experiences in the process of writing up this project, and is relevant to the women who took part in this project.

My personal connection with these ideas is my family setting of thirty years ago in which men and their interests were given high value and status while women’s concerns – that is my mother’s and grandmother’s – came second. These values were supported by both the men and women in my family’s household. I received conflicting explicit and implicit messages from my family. The explicit message was that the life path to take that would give me the most personal satisfaction was

to get a university education in the sciences as modelled by my father and grandfather who were both high achieving academics and doctors. The implicit message was that a women's path was to marry and have children and that this was to take priority over any career considerations. Modelling this as adult women, both my mother and grandmother were mainly involved with childcare, (my mother returned to university when I was eighteen). The objective scientific knowledge held by the men in my family was considered 'weighty and real' while women's less intellectual concerns were not recognised as valuable knowledge at all. Thus in my family knowledge that was valued was academic, intellectual and preferably medically scientific. I took on the underlying message, left school early before A levels and was married with a child by the age of twenty two. In so doing I was utilising and building on my womanly knowledge as a mother and leaving behind the academic, scientific learning associated with the men in my family.

The ways of knowing that were so clearly divided along gendered lines in my family correlate with Belenky et al.'s categories of connected and separate ways of knowing (Belenky, Clinchy et al., 1986; Goldberger, Tarule et al., 1996). Separate knowers apply objective, impersonal standards that have been 'agreed upon and codified by logicians and scientists' (Clinchy, 1996) in other words the knowledge held by my father and those that adhere to the paradigm he represents. Separate knowers question and look for flaws in arguments, possible misinterpretations and are interested in accuracy and precision. They play a 'doubting game' (p206) and view the world from Buber's 'I-it' perspective, (Elbow, 1973 quoted in Clinchy, 1996, p206) as external and observable, known through recognition of its difference from the observer. According to Belenky et al. separate knowing has been mostly developed by men and is more difficult for women, while an easier mode of knowing for women is *connected* knowing. They stress that this is not absolute, men can be and some are connected knowers, while women can be and some are separate knowers. It is unclear from Belenky et al.'s writing whether connected knowing is indeed predominantly a feminine attribute as many of their core references e.g. Buber, Elbow and Rogers, are men.

Connected knowing views the world from an 'I-thou' perspective (Buber, 1958), what is seen out there is known by how the observer experiences it; it is a subjective way of knowing. Connected knowers know through putting themselves in the position of that which they seek to know. They use processes such as sympathy and empathy and focus 'not on propositions and validity of inferences but on experiences or ways of seeing' (Elbow (1973), quoted in Clinchy, 1996, p206). According to this model I am most strongly a connected knower. As such I play "a believing game" more easily than a "doubting game" (Elbow, 1973; Clinchy, 1996; Goldberger, Tarule et al., 1996). Connected knowing is recognised within Gestalt where it translates to field theory (Barber, 2006). This is described further in the following section (page 37).

I see connected knowing as relating to the aspect of psychotherapy work that involves obtaining a sense of the inner world of another. In this I attempt to become as close as I can to knowing another's experience and communicating that understanding. Belenky et al. state 'connected knowers know that they can only approximate other people's experiences and so can gain only limited access to their knowledge' (p113). Thus connected knowers also recognise the gulf of difference that exists between people. I can never fully know what it is to be another person, but I may be able to connect across the space between us.

Belenky et al. found that while separate knowing tended to be valued in educational and academic institutions, connected knowing remained unacknowledged in these settings. (Goldberger, Tarule et al., 1996, p113). They introduced both separate and connected knowing as rigorous procedures for making meaning (Belenky, Clinchy et al., 1986, p100). In their book these two modes of knowing are presented in the context of a developmental model of ways of knowing which progresses from received knowledge, through subjective knowledge and procedural knowledge (separate and connected knowing), to constructed knowledge which is the most evolved. Constructed knowers are able to question 'the frames and systems authorities provide and create their own frame' (p134), while all preceding forms of knowing operate within those frames. Belenky et al. seem to suggest that it would be preferable and a higher stage of intellectual development to be a constructed

knower than a separate knower. This implies an ideal that a person might strive towards i.e. to become a constructed knower. The concept of being a type of knower suggests a fixed characteristic rather than a way of gaining understanding.

Debold, Tolman et al. suggest that both men and women have a tendency to hide qualities in their thinking that are not easily accepted as characteristic of their gender. Thus while they combine different ways of knowing only one may be visible and others suppressed. For example they suggest that 'doubting' is seen as a masculine quality, which if shown by a women might not be well received.

This would cause a woman to split off her doubting qualities and keep them to herself (Debold, Tolman et al., 1996, p238). In this they identify private and public ways of knowing, which presumably operate for both genders.

I identified with Belenky et al.'s description of knowledge development and connected knowing. They describe a scenario so close to my own that I felt when reading that at last someone was by my side, seeing and understanding my predicament. For example the following statement 'because so many women are already consumed with self-doubt, doubts from outside seem at best redundant and at worst destructive, confirming the women's own sense of themselves as inadequate knowers' (Belenky, Clinchy et al., 1997, p228) describes well how in the course of this writing I collapsed in the face of criticism and easily believed that I would not manage to achieve the challenge set by this doctorate (an outcome which at this time of writing is unknown).

A warning about over-identification with this material comes in a critique from Clinchy who suggests that a strong sense of recognition, rather than being an affirmation that Belenky et al. are on the right track, might point to a 'makes sense epistemologist', someone 'who accepts whatever appears at first blush to be true' (Greeno & Maccoby, 1986, p135 quoted in Clinchy, 1996, p238). Certainly the excitement and sense of recognition I felt on reading this book made it difficult to step back and think more objectively about what was being said.

Gestalt and Evolutionary Theory

In this section I turn to considering the relationship between two strong influences in this project; Gestalt theory and a Darwinian perspective in relation to stepfamilies. I use the original book ‘Gestalt Therapy, Excitement and Growth in the Human Personality’ as the sourcebook for discussion on Gestalt (Perls, Hefferline et al., 1951) and ‘The Truth about Cinderella’ (Daly and Wilson, 1998) for the Darwinian view.

Among the questions that have guided me in this investigation of mothers are: What are my feelings as a mother? What is the nature of what a mother feels towards her own children, and how does that differ from children that are not her own? How does a mother *feel* as a mother, what does she perceive herself to be? What might be the cause of such feelings?³⁶ In seeking to answer these I have deeply connected with my own and each participant’s motherly experiences in stepfamilies.

The assumption within Gestalt is that we know through our own senses, that knowledge is held within the body, is felt and known through self-enquiry. From this view I know another’s experience through how I receive and make sense of their words. I also know through their response to me how closely I have understood and represented what they are telling me. The process of imparting what is known through experience to another is primarily (but not only) through words. It is these words that constitute narrative, i.e. the telling of experience.

As described throughout this document, my investigation into mother’s experiences has been addressed through a Gestalt framed methodology incorporating methods of phenomenological inquiry. Data can come from a direct source ‘the horse’s mouth’ as I can look into my internal experience and ask others to report on theirs, and this is what I have done. However if I ask about the *causes* of certain feelings then I

³⁶ Beneath these questions I have assumed that mothers *do* feel different towards their own children, that most mothers have made a commitment and feel a strong emotional and physical connection towards their own children (Salisbury 2004). These assumptions have been put to one side so that I could discover whether this is born out, from the mothers themselves.

have had to speculate as this has not been the thrust of this inquiry. Therefore I have looked towards others explanations.

Daly and Wilson's Darwinian perspective offers a rationale for special feelings that mothers and fathers hold towards their own children (see discussion starting on page 29). They describe these feelings as stemming from primitive and biological drives built deep into our nature that promote the survival of our genes; we have an investment in our children. This is important because stepparents have no genetic or biological connection with their stepchildren, and therefore perceptions of genetic kinship and accompanying behaviours and expectations are not present in their relationship with them. My bias towards a biological explanation stems from the surprising strength of my own feelings as a mother and stepmother which have felt compulsive and irrational. The influence of my medical, scientific family of origin also tilts me towards biological explanations for this.

I now consider Gestalt field theory and what it has to offer regarding mothers in stepfamilies. Gestalt field theory draws attention to the inseparability of an object from its context. A simple example is that of a fish. The fish lives in water, if I take it out of the water it dies, therefore to know something about what a fish is I have to know something of water. Here is how field is described in the original book 'Gestalt Therapy' (Perls, Hefferline et al., 1951):

It makes no sense to speak, for instance, of an animal that breathes without considering air and oxygen as part of its definition, or to speak of eating without mentioning food.....there is no single function of any animal that completes itself without objects and environment.....Let us call this interacting of organism and environment in any function the "organism/environment field"it is always to such an interacting field that we are referring and not to an isolated animal.

The human organism/environment is of course not only physical but social. So in any human study such as human physiology, psychology or psychotherapy, we must speak of a field in which at least social-cultural, animal and physical factors interact (Perls, Hefferline et al., 1951, p218).

This argument sets out the basis for Gestalt field theory. The language seems biological; and the human being is described as an organism and animal. In this model there is no such thing as independence, only interdependence. A sense of independence therefore is an illusion. In this extract we are told by Perls et al. that the field model is true and logical as they say that ‘it makes no sense’ to see things other than from this perspective. It is noted that there are many environments that constitute the field that a human is both part of and interacting with; the conclusion is that a minimum of these must be considered³⁷.

Field theory is a universal vision. However, it is hard to conceive as is the concept of the never ending quality of space. Everything constitutes the field, and yet *everything* is the ultimate catch-all category. In fact existence is extremely varied; it cannot all be taken into account under one heading. I therefore feel that field needs to be thought of as multi-dimensional.

While the environment is un-boundaried, human beings are not. Perls et al. describe there being an edge or boundary that separates ‘the organism’ from the environment. It is at the boundary that interaction with the environment takes place. The second volume of their book starts as follows:

Experience occurs at the boundary between the organism and its environment, primarily the skin surface and the other organs of sensory and motor response. Experience is the function of this boundary (Perls, Hefferline et al., 1951, p227).

These ideas applied to the concerns of this study would say that women’s experiences also occur at the boundary; the meeting point between themselves and the environment, an aspect of that environment being their stepfamily. On examination I found many interacting environments that women were part of and that these include family, society, their own psychology, history and so forth (see ‘domains of influence’ on page 125).

³⁷ The perspective of the indivisibility of field and organism also relates to Husserl’s intentionality in that every act ‘is completed by’ an object in the environment (Moustakas, C. R. 1994).; we are angry *with* something, sad *about* something, mother *to* someone and so forth.

The people who developed Gestalt theory were originally analysts. Their ideas were in part a critical response to Freud (see Perls, Hefferline et al., 1951, Chapter III). They saw knowledge as arising through experiments aimed to bring to awareness hidden parts of the person, and argued that Freud's theories were unnecessarily complicated.

However Fritz Perls' famed injunction 'lose your mind and come to your senses' (Perls, Hefferline et al., 1951, p69) encouraged blind faith and anti-intellectualism, despite the fact that he and other Gestalt Therapy founders were cultured, academic thinkers and doctors (see Perls and Rosenfeld, 1982). The original trainings in Gestalt Therapy were likely to be entirely experiential, with trainees emerging with no idea of the theories that lay behind their trainers' actions (Wymore, 2006, p7). Thus there is a religiosity and idealism within the Gestalt thinking. In the following passage the field, or environment, is described as godlike, existing out of awareness but available if we would dare to take the step to meet it.

.....for faith is knowing beyond awareness, that if one takes a step there will be ground underfoot: but one gives oneself unhesitatingly to the act, one has faith that the background will produce the means (p343).

The context for this quote is a description of how initiative that is present in a child is not fulfilled when that child becomes adult because:

in our economy, politics and education, our goals are too alien and the ways of reaching them too complicated...to be realised satisfactorily ... [and] the system of education results in a number of unassimilated introjects (p343).

the result of this process they say is that adults have lost trust in the environment as providing the means for fulfilment.

Daly and Wilson's Darwinian ideas on stepfamily dynamics are as passionately advocated as Gestalt was by the early Gestaltists. As discussed earlier (on page 29) they claim to be holding a realist view that is ultimately responsive to human needs (Daly and Wilson, 1998, p66) ; I have described earlier how their stance on stepfamilies is not just disagreed with by many social scientists, but that their use of

abuse statistics is considered untrustworthy, and their arguments dangerous (Daly and Wilson, 1998; Mason, 2000).

The theory of evolution suggests that the dimension of the 'animal' in a human being is the primary drive behind human behaviours which have developed to ensure the survival of our own genes. With this in mind Daly and Wilson ask 'why do stepfamily relationships work out reasonably well? Why do they even exist?' (p62). In this they compare human behaviour with baboons as 'male baboons are sometimes solicitous towards particular infants they could not possibly have sired (p64). Their explanation is that a stepparent's tolerance towards his or her stepchildren constitutes benefits which entitle the stepparent to reciprocal considerations (p64). This question raises issues about morality and whether there *really* is such a thing as altruism, and within this model what would be its purpose? Certainly several mothers seemed to be describing altruism in relation to their stepchildren. For example Esther described that she loved nurturing and enjoyed her stepchildren in their own right. Leanne described strong empathic feelings for her stepson, who seemed to be left out of his mother's new family; these responses to stepchildren seemed to exist for their own sake. They appeared to be womens' responses to the needs of children. The act of nurturing and giving arguably brings its' own satisfaction, irrespective of mating considerations.

As Mason points out, much Darwinian Theory is based on statistics that can be manipulated and also in their imaginations of the characters of original human beings. As these beings are no longer with us the theories are cannot be proved and must be seen to be beliefs based on fantasy.

Most evolutionary scientists believe that modern behaviour regarding reproductive activities has been seriously distorted by a culture that no longer represents the conditions of the Pleistocene age, when our genetic propensities were firmly established. They prefer to focus on animal behaviour or isolated "primate tribes" where behaviour has presumably not been tainted by modern conditions' (Mason, 2000, p257).

At this point, something of the idealism of Gestalt might be seen with its vision of a 'primitive' motivation that has been overlaid by the concerns of contemporary life. Gestalt practices frequently uncover underlying strong feelings that seem primitive in their power and self-ishness³⁸. Gestalt on this level might be seen to be a process of coming to terms with these 'animal' emotions. Within a stepfamily such emotions might include love, hate, competition, belonging, and not belonging.

Within both Gestalt and Evolutionary theory there is a down-to-earth, gritty quality; an interest in what is real as opposed to how we would like things to be. Therefore Gestalt and evolutionary psychology are in some respects comfortable bedfellows; evolutionary psychology offers a theory for the emotions, feelings and drives that a Gestalt phenomenological practice can uncover underlying 'civilised' behaviour.

Overall evolutionary theory and Gestalt theory both provide frameworks that can explain the types of feelings and validate the relationships that take place in stepfamilies. While the cause of feelings and perceptions towards children and stepchildren might be argued, the fact of these feelings' existence is not.

³⁸ The hyphen here is deliberate; the intention is to suggest a positive emphasis on the self, rather than the usual negative meaning.

Specialist Seminars and CARPP Conference

I have greatly enjoyed the program of specialist seminars that have been intrinsic to this doctorate. As a result I attended ten, eight of which I discuss here. I also attended a conference put on by CARPP (the Centre for Alternative Research in Professional Practice) on Ways of Knowing and Forms of Representation. I describe this briefly on page 62, with thoughts on a drama workshop on page 450 .

SEMINARS ATTENDED

Trauma and Attachment

15th March 2004 Jill Straker

What Can we Learn from the Therapist's Body

3rd December 2004 Susie Orbach

Outside Witness Practices: a Method of Collaborative Inquiry

14th January 2005 Jane Speedy

Learning from Reflexive and Narrative Enquiries: Content, Methodologies, Methods, and Using our Selves in Research

27th May 2005 Kim Etherington

Prioritising People or Knowledge? Tensions between research and professional ethics

13th January 2006 Tim Bond

Imaginative Writing as Psychological Inquiry

30th June 2006 Miller Mair

Who Own the Unconscious? How developmental research affects psychodynamic models of the mind

1st December 2006 Jean Knox

Discovering the pros and cons of developing a multi-model, multi-cultural approach

27th April 2007 Isha Mckenzie Mavinga

Psychotherapy and the Quest for Happiness

15th February 2008 Professor Emmy van Deurzen

Autobiographical memory, the body and self in time

14th March 2008 Professor Andrew C. Sparkes

i) Jane Speedy

Outside Witness Practices: A Method of Collaborative Inquiry

I had not come across Jane Speedy's work before and was interested to find out if her collaborative inquiry methods would be relevant to my project. I wanted to know more about story and how it applied to research. .

The most memorable part of Jane Speedy's presentation was a live 'definitional ceremony'. This was a form of witnessed interviewing – a staged ceremony where the focus was on a storyteller who was interviewed by Jane Speedy while watched by the group. The group were then interviewed by the participant, so witness, interviewer and story teller were interchangeable positions. It demonstrated the power of witnessing and feeding back in both elucidating a story and transforming it.

As I write this several years later I remember this witnessing, while the rest of the seminar has faded away from my mind. I am reminded that I learn best through *experiential* learning; through activities and participation more than through being told. It is these teachings that 'stick'. I had not considered the role of the witness previously, although in my work as therapist I am witness to my clients' stories and 'interview' them with a view to potential transformation of those stories.

I felt that this exploration of 'story' presented a model of change that is also held within Gestalt theory as I practice it but with a different frame. In Gestalt it would be described in terms of field, figure and ground; and the paradoxical theory of change. The ceremony might be described as an example of interactional influences of field on figure and figure on field, with the witnesses and key participant as human embodiments of field and figure.

I took from the seminar:

- * the concept of witness and the value of a *witnessed* story
- * A vision of the activities of this project as a process of interviewing, storytelling and witnessing in several interlinked forums. As researcher and interviewer I have witnessed and elucidated the stories of participants. I have re-produced them in my own 'doctoral' story, and through sending this back to participants, they have become witnesses to this story.

- * A vision of knowledge development in the form of witnessed telling, receiving feedback and reviewing.

ii) **Kim Etherington**

Learning from Reflexive and Narrative Inquiries;

I attended Kim Etherington's seminar as I had been inspired by Jane Speedy's presentation on story and narrative. I was writing my learning agreement at the time and felt that I might use a narrative methodology for exploring the experience of stepfamily members.

I found that I identified with Kim Etherington who is a counsellor/researcher. I was particularly interested in the practice of reflexivity, which allowed a means of bringing the self into research. She encouraged research enquiry and writing that included stories of the self and others, bits and pieces of interviews and imaginative tales. Overall I saw from her seminar that it was possible to be creative, interested in your own experience as well as other people's and that research can be presented show through empathic and evocative texts.

I took from Etherington's seminar:

- * a connection between narrative and Gestalt.
- * encouragement to use narrative research, with reflexivity as the means of bringing myself into the research and in presenting interview material.
- * the possibility of expressing myself creatively in the service of research and academic writing. This came with the insight that I was repeatedly repressing myself because I feared being judged for not being clever or academic enough.
- * I recognised a previously unseen motivation for becoming a doctoral candidate which was to connect with my family of origin. I have written about this in the preface. This led to identifying that the entire project as I envisaged it contained themes of closeness and distance, connection and separation, identification and non-identification, self and other.

iii) Tim Bond

Prioritising People or Knowledge, Tensions between Research and Professional Ethics.

Before Tim Bond's seminar my attitude towards was that they were boring but necessary. However his presentation changed that entirely. I found his knowledge and authority on the subject made his presentation fascinating and clear. Far from being a dull subject he showed that ethical dilemmas as interestingly complex and that their resolution frequently requires a creative approach.

I learnt from this seminar:

- * that ethical questions within research are more easily raised than solved and that relationships can be a vehicle for ethical practice.
- * to recognise ethical behaviour as a matter of personal responsibility.
- * That in the service of responsibility, ethical guidelines *must* be questioned – as opposed to being rebelled against. This is an important distinction. By questioning I mean that an aspect of an ethical attitude is to not adhere to rules and guidelines blindly.
- * That ethical issues invariably arise in relationships between people and an ethical attitude includes the willingness to negotiate these.
- * I recognised that power issues are intrinsic to all relationships and are an important consideration in research on human experience. Bond's exploration of 'an Ethic of Trust' which was discussed at the seminar and the subject of pre-reading for the seminar spoke to this.
- * That ethical considerations which are important in psychotherapy practice between psychotherapists and their clients, transfer to relationships between researchers and participants. However an important difference between research and psychotherapy is that research is intended for the public domain, while psychotherapy is private. This changes ethical practices regarding confidentiality and issues around anonymity.
- * I identified that participants trust me as researcher to be ethical, that I demonstrate this through being transparent about my own experiences, by raising pertinent issues with participants and through being willing to discuss and modify my view.

iv) Miller Mair

Imaginative Writing as Psychological Inquiry

I looked forward to this seminar as I felt from its title that it would be ‘fun’ and useful to help me through my writers’ blocks. However, while Miller Mair offered some valuable thoughts about writing, I felt he gave an example of how not to run a seminar. He gave some brilliant ideas for creative insights through writing and in particular the idea of the self being a community of selves. However I felt he talked too much without giving space to process the material he was presenting. All space for discussion took place in the large group. This meant that it became a competition to talk and that the flow of conversation went one way between him and the person talking. Furthermore, as the seminar progressed it became an account of his battle within academia for his methods to be recognised and accepted. The final hour became a conversation between him and one other doctoral candidate on this subject. This was difficult because several of his writing exercises involved self-inquiry which raised uncomfortable insights. In other words his explorations were psychological in nature but he did not demonstrate psychological sensitivity in how they were presented.

This seminar was in many ways useful, and provided some excellent ways of exploring data and for creative writing. However I felt that I learnt more about the potential pitfalls of presenting a seminar through what I saw as thoughtless time planning.

I gained from this seminar:

- * The concept of the self being a community of selves, for example a few within my ‘community’ contains among other characters a Gestalt therapist, a housewife, a gypsy, a mother, a stepmother, an adolescent, and so forth, All jostling for a voice and position, some talking louder than others.
- * To consider when writing who (within myself) is doing the writing as well as who I am writing for.
- * That good material can be lost through insensitive presentation and that spacious timing is important for maximum learning potential. Thus when presenting in a seminar it is important to recognise the impact of material and to ensure that there is a

place for thought and digestion of material, particularly if it has been disturbing in any way.

- * That large groups are not always the best place for discussion as people can find themselves vying for space and attention rather than being able to express their thoughts freely.

v) Dr. Isha McKenzie Mavinga Discovering the pros and cons of developing a multi-model multi-cultural approach

I attended Isha Mackenzie Mavinga's seminar at a time when I was feeling unconfident about my research. At the time I felt that my work wasn't academic enough, that I was entirely at sea with my methodology, that I had some good material but did not know how to put it together.

I understood from Mackenzie Mavinga's presentation that she found the process of her research was also a developmental process, and that her personal struggle was to find a voice. Her project on bringing forward the voices of black people in counselling trainings was therefore analogous to what she found she needed to do for herself.

Mavinga Mackenzie's background is a combination of cultures and race in that she is black and Jewish, raised in a children's home as an Anglican. Thus her subject is an example of a research issue arising out of the experience of the researcher. In her self-published booklet 'A Space to Contemplate' she writes 'as a child raised in care my heritage was dismissed and in a similar way I endured my fair share of racism and ignorance about my personal development and cultural needs' (McKenzie-Mavinga, 2005). The personal development that took place as a result of her research was to find her voice.

Among the methods of exploration Dr. McKenzie worked with during her seminar was to write freeform on the dialogue of difference. I present what I wrote here as an example of how writing quickly, without too much thought can release understandings that tend to be edited out otherwise. I saw that there are dialogues around race and difference that frighten me and I become inhibited because I am uncertain about what I would find in myself and of blundering into a cesspool of unacceptability. What I understood is that black people's

concerns when raised, tend to get swamped by people dealing with the white person's feelings of guilt, fear and so forth.

I'm aware of my own fear and questions, I get shaky. I am convinced that deep in my gut I am, I must be racist. It's a concern, I don't want to offend, I am offensive, or perhaps just inconsiderate.
The violence of the past doesn't just disappear.
There has been violence towards me and mine.
What does that mean for me, for you,
For us
Together and separate.
There is a depth here and grief, sadness, fear
And hope for a meeting.
But what if that meeting can't be? Is the divide too big?
What happens to our common humanity.
Does my past, who I am
Become oppressed by yours, who you are in a hopeless missing
Or can we truly open our hearts to each other?
You ask me to make space for you
You insist consistently, calmly, firmly with determination
Like a raindrop dripping on a rock.
'Hear me, I am important, this is important, give me space, attention,
Respect, a right to live'.

(Claire Asherson Bartram April 2007 – written as part of specialist seminar)

It was useful for me to see the possibilities of a research project that drew on several methodologies rather than adhering wholeheartedly to one methodology (McKenzie Mavinga, 2007).

From this seminar:

- * I was inspired to consider conversations that don't easily take place in stepfamilies, what is not said or easily revealed. My thoughts, based on how I feel, were to suspect that many women feel ashamed about any difficult feelings they hold towards their own children as well as stepchildren. I thought of how the dynamics of oppression work within stepfamilies as well and that they might operate in the different positions held by stepparents and parents. Papernow (1993) proposes that an important stage

in building a cohesive stepfamily is for these positions to be heard and understood by each other. Thus her work provided food for thought within my own area of interest.

- * I felt supported by Isha MckEnzie Mavinga's approach to her project in which she said 'the process chose me'. This spoke to my own sense of undertaking this project on stepfamilies with the direction appearing in front of me. I have said elsewhere that it was as if I was doing what the project demanded rather than imposing my will on it. It was helpful to see someone who had achieved their doctorate and appeared to have found her way through what looked like a similar process.
- * I was encouraged to trust my own path, methods and instincts.

Jean Knox

Who owns the unconscious?

I understood that Jean Knox she would be discussing the boundaries of her Jungian analytic therapeutic orientation with other orientations. I imagined that her seminar would be of interest to me as a psychotherapist and that we might touch on the boundaries between an analytic and Gestalt/humanistic therapeutic context. On the flyer announcing this seminar she wrote:

The continuing reluctance of therapists of each discipline or orientation to give any credence to each others' models means that the concept of the unconscious itself remains static and undeveloped. Each group needs to 'own' the other's model has value or we remain stuck in a sterile feud between the pre-determined positions of partisan groups.

However, in the writings she distributed, and within the seminar, it became clear that her context for other's models was analytic only. She seemed to be unaware of or give little value to humanistic orientations that present a different model. For example Gestalt therapy does not offer a model of the unconscious but is more concerned with what is in and out of awareness and interactions that take place in the present. In the course of the seminar she gave the example of a client who had become very upset about a pattern on her carpet. She had offered an interpretation and the client had calmed down. When I suggested that a gestaltist might have worked differently, she stated that she thought Gestalt would not be able

to deal with someone so disturbed. It seemed in this that she was quickly discounting of Gestalt in favour of analytic orientations, without being curious to know more. Her concerns were around analytic orientations and the challenges to them, without acknowledgment of the validity of the humanistic strand of psychotherapies.

This is a prejudice I have come across previously with people from analytic orientations. I have frequently felt in analytic forums that analysts are referring within their own context and that other orientations are discounted. This becomes irritating when an analytic therapist seems to be describing ways of working as if they have just been discovered, when they have in fact been practised as part of another orientation for many years. An example took place in an earlier seminar with Susie Orbach (What Can we Learn from the Therapists' Body 3rd December 2004). She presented on the language of the body. In the room were a selection of therapists, including Body therapists and Gestalt therapists both of whom work with the body. Orbach presented her ideas in this group as if working with the body was revolutionary. This was challenged by several members of the group.

On reflection, there was not any direct connection with Jean Knox's subject and my doctoral project. However the issue of boundaries, difference and prejudice and the bringing together of different cultures and perspectives relate to key issues within stepfamilies. In a stepfamily, different groups (which in a stepfamily are people from different families) have different assumptions and styles. One group may feel justified in seeing their own way as better than another's and fear being 'diluted' by connection with the other. The dynamics of this seminar showed up the difficulty of recognising the contexts and assumptions that a person is embedded in.

Emmy Van Deurzen

Psychotherapy and the Quest for Happiness

I went to Emmy Van Deurzen's seminar, thinking that a search for happiness is fundamental motivation for people. The relevance to stepfamily dynamics is that people search for happiness in relationships. New relationships when a previous one has failed could be seen to represent hope for success in a relationship. Therefore, stepfamily situations come about partly because people want to be happy.

I found this a valuable and thought provoking seminar. Emmy Van Deurzen's offered an interactive presentation that was friendly, warm and knowledgeable. Her passion for her work came through strongly. As a group we were invited to explore the meaning of happiness, what it meant for us. Answers included: a warm feeling, feeling relatively content with myself, achievements or people I love, satisfaction and not being weighed down. Queries raised by the group included whether happiness was a valid goal or whether there might be an underlying happiness that encompasses other feelings such as sadness and anger and so forth.

Van Deurzen questioned psychotherapies that aim solely to make feel better and set this against therapies that support a person to make meaning of their lives and emotions. She described existential therapy as supporting people to value live and grow from their more difficult feelings and conflicts. These thoughts stimulated discussions on resilience and the means by which people overcome obstacles.

From this seminar I gained:

- * a consideration of what people are wanting from their families. Raising questions such as 'what makes some families resilient and others not?'
- * The thought that facing the difficult reality in a stepfamily often means to face that this new family is not what has been hoped for and to accept the family that is (Papernow, 1993).
- * The example of an inspiring presentation with a presenter who was open, knowledgeable, willing to question and to be seen as not- perfect.
- * That it is far easier to take on board someone's thoughts if I agree with them but harder to criticise them. Criticism is easier towards someone who has a different perspective, such as Jean Knox (see previous seminar).

Andrew Sparkes

Autobiographical memory, the body and self in time

I first came across Professor Andrew Sparkes at CARPP'S conference. I felt inspired by his presentation on autoethnography and suggested that he would be suitable presenter for one of Metanoia's specialist seminars.

Andrew Sparkes is a champion of auto-ethnography and narrative methods of research and representation. In this vein he uses story, both autobiographical and fictional written in the first person to present what he knows of disability and men's bodies. His expertise has developed out of his own history in that he started his career in rugby, and was forced to stop due to an injury. He now experiences frequent pain. His seminar began with him describing how he 'accidentally' became an academic thus setting the scene for his creative approach to research.

The paper that Professor Sparkes circulated for prior reading was titled 'Embodiment, Academics and the Audit Culture: a story seeking consideration' (Sparkes, 2007). In this he presented the tale of an academic experiencing breakdown. It was a story that covered important issues within the university system and was research presented in fictional form. As Sparkes describes: 'the constructive process is inspired partial happenings, fragmented memories, echoes of conversations, whispers in corridors, glimpses of myriad reflections seen through broken glass, and multiple layers of fiction and narrative imaginings' (Sparkes, 2007, p522). The latter part of this paper consists of reactions to this paper from various academics, five of whom are at different stages of their careers. Each one commented on the evocative power of the piece and that they were led to reflect on their own experiences in the culture that the paper was commenting on. Within this experimental approach Sparkes is well able to account for himself, recognises the controversies within his work and is familiar with conventional academic requirements.

Sparkes' work was relevant to my project in the manner of his inclusion of biographical material in academic presentation. But for such work to be convincing it needs to be backed by the researcher being able to account for themselves and the thoroughness of the context. Encouraged by his example I took risks in writing about myself in order to join with other women who might read this and as an attempt to express what I was getting at through showing my own vulnerabilities. Sparkes also proposes that research be validated according to the values it holds, which I have taken on board (on page 219).

Emerging Approaches to Inquiry 11:**Ways of Knowing and Forms of Representation****Organised and led by Judi Marshall, Peter Reason and Sue Porter****13th – 16th September 2006**

The flyer for this conference described it as one of a series set up ‘to develop approaches to inquiry that go beyond the limitations of the positivist and objectivist scientific paradigm and aimed to be an exploration of multiple ways of knowing’ (see flyer, Appendix III on page 436). I went to this conference with the intention of understanding more about the rationale for creative methods within action research and qualitative inquiry. I was hoping to find a means of loosening the extent to which I felt that ‘real research’ needed to be objective, empirical and scientific, of integrating the experiential and intellectual aspects of my project, and becoming more confident in my ability to carry out a doctoral project.

I felt nervous going to this conference, not knowing anyone, unsure of my place among a community of academics and feeling like a fraud. I found myself quickly welcomed by people and interested in the material being presented. The keynote workshops were from Andrew Sparkes on auto-ethnography and Adrian Jackson, a Theatre Director who uses theatre for political purposes and works with the homeless in London (see Appendix III on page 450). In addition to these presentations the conference included large group meetings, contributions from participants and practicum Groups - groups of eight people which were forums for exploring participants’ own projects. Many participants were students or alumni from Bath University, wanting to use creative research methods in work within their organisations.

I was surprised to find that this group of academics used research techniques which were familiar within the psychotherapy world; techniques such as art, free-fall writing, storytelling, drama and discussion. When I said that I saw this as a connection between qualitative research and psychotherapy several people replied that this was definitely not psychotherapy. I therefore found myself throughout the conference holding the questions ‘what is the difference between this research and what I do in psychotherapy?’ I felt confused by the overlap between what was taking place within this forum and with therapeutic explorations, because what I was seeing was a fuzzy boundary.

An example of how the approach of participants at this conference differed to a therapeutic approach arose in my practicum group and led to insight that was an important stepping stone for this project. The situation was a continuation from an incident that took place during Adrian Jackson's presentation of 'Theatre of the Oppressed' - a form of participatory theatre designed by Augusto Boal used as a vehicle for political change (see Boal, 1995). In this presentation Jackson directed a small play (created by us) in which a woman had her handbag snatched. The audience were invited to intervene and invited on the stage to act out how they might stop this happening. In this process one man (the rescuer) physically tried to stop the assailant by swinging a bag at him. Suddenly, the man who was acting the assailant shouted - he really lost his temper - it was shocking. It transpired that the man who was the assailant was the rescuer's supervisor. Both of these people were members of my practicum group.

Within the practicum group both men refused to address this, with the rationale that this was not therapy and they did not want it to be therapy. An uneasy feeling of something unfinished lingered in our meeting which meant that conversation was rather stilted. At this point someone else suggested that we do a story-telling circle. I felt annoyed by this; I wanted the two men to deal with their relationship directly as they would have done in a therapy group. Story-telling I saw as a distraction and deflection. However I was outvoted and story-telling was what we did, with each member of the group telling a story that came out of their lives. Each story sparked another and eventually I told a story about my father and how distastefully messy he was when cooking. When I finished there was a silence and I felt incomplete I thought 'I haven't told them how much I loved him'. I then went back into telling and this time the tale was deeper. I talked about his death, that I missed him, about how I longed for us to understand each other, how out of my depth I felt in his scientific world and how this relationship had brought about a block in my ability to learn. At the end of this story other group members were silent and thoughtful; it was a moment that would have been entirely in place in a therapy group. The prologue for this document came out of my exploration through this story.

Overall I learnt at CARPP that there are thin boundaries between self exploration within qualitative research and the self-development aspects of psychotherapy. It is important to make the distinction because self-exploration within research must be in the service of the research rather than some form of self-confessional. However working as a therapist gives the researcher a psychological awareness that supports such explorations. To evoke

disturbing material in the course of research, without combining this with psychological awareness at worst risks harming participants through not offering adequate support. It also dilutes the learning that takes place. Examples of this could be seen in Miller Mair's seminar (see above). Also Adrian Jackson might have insisted on time for personal repercussions from his work to be processed. I also found that I had a place in this academic community which was very affirming. In my notes I wrote that I thought I had found my academic home and importantly 'it's easier than I think'.

Conclusion to Specialist Seminars

The range of seminars offered by Metanoia was interesting and varied. It was unclear whether presenters were themselves clear on what they were supposed to be doing. This meant that some presentations were more useful for the doctorate than others. However it is interesting to see that I learnt a lot through those seminars that I judge as unsuccessful, in a negative way. In that respect nothing seemed wasted, it was as useful to attend a 'bad seminar' as it was a good one. If I had only attended seminars with people I liked and that I agreed with, I would not have had the opportunities to see out of my own box and question my own contexts and assumptions. It was immensely valuable to attend CARPPS conference and I would recommend it to any candidate who felt interested in creative developments in qualitative research.

Emerging Approaches to Inquiry II
Ways of Knowing and forms of representation

Wed 13th to Sat 16th September 2006

Hawkwood College Stroud UK

Organised and led by Judi Marshall, Peter Reason and Sue Porter

with support from Postgraduate Research Students

Centre for Action Research in Professional Practice (CARPP)

School of Management

University of Bath

This experiential conference is the eleventh in the series that we inaugurated in 1986. Our intention is to continue our exploration of approaches to inquiry that go beyond the limitations of the positivist and objectivist scientific paradigm, which, while challenged, continues to hold much power in academia and in popular images of research. We seek to develop theory and practice of inquiry drawing on a range of approaches including self-reflective practice, action inquiry, co-operative inquiry, feminist research, democratic action research, participatory action research and others. We often adopt the term *action research* to refer to these approaches because they share concerns that knowledge should be useful in action and that inquirers should seek to enhance the quality of their own practice. *And* we see this as a broad ranging, diverse and evolving territory in inquiry theories and practices, valuably rich and pluralist.

At the 2006 conference we shall experiment with a range of activities to experience multiple ways of knowing and explore different forms of representation, including attending to the politics of knowing. We want to open a creative space to which participants can bring their own questions. We intend to explore the following issues, and more that arise as we join together.

How we can engage our muted sensibilities and voices, to access our own knowing more fully and multi-dimensionally;

How we come to trust what we know, especially as it informs action;

How we can listen to aspects and voices of those parts of organizations, societies and our ecology which are not always articulated, recognised or trusted (by others or even ourselves) as we seek to act for change in the world;

How we can articulate and communicate such knowing, including in the academy and when we are seeking to subvert potentially oppressive frames and practices.

In action research we advocate the use of **multiple ways of knowing** so that we can be fully alive as inquiring subjects. In our research community at Bath, we sometimes use John Heron's extended epistemology as a helpful framework, identifying experiential presentational and practical knowing as significant in their own rights, rather than giving propositional knowing primacy. We draw on the work of Belenky, Clinchy, Goldberger and Tarule (1986) who also name multiple forms of knowing: silence, received, subjective, procedural (separated or connected). Respecting these author's significant contribution to reclaiming 'women's ways of knowing', we would also use these notions more generally, especially in relation to knowing which might be repressed in some ways. There are many other frames seeking to expand our senses; for example we might also use terms such as sensory, intuitive, embodied or spiritual to describe forms of knowing.

A closely connected stream of exploration is **how we can explore and represent our knowing**. At Bath, we have engaged in various activities – such as psycho-drama, drawing, free-fall writing, collage-making, working with social dreaming and developing forms of mindfulness – to open our senses and experiences. These explorations might give us more understanding of phenomena we research – as when we enact a situation and gain insights into its potential qualities- and move us towards connected knowing and forms of representation, we can use to communicate our inquiries – as when we offer pictures or music alongside text, to enhance and amplify the latter's meanings. They enable us to work with what might otherwise not be expressed. As thesis formats become more permissive (although not un-problematically so) and technology enables different forms of representation, the opportunities of expression are expanding, even within mainstream academia.

The conference will offer opportunities to explore these twin areas, and for participants to work on their current inquiries. Doing this means we engage with **the politics of knowing**. We open the possibilities of experiencing muted sensibilities and voices we all carry, and therefore encountering the processes that contribute to their muting, silencing, repression and oppression. What can we learn as we explore? How can we weave between the personal and the political in our inquiries? How can we express these understandings, for ourselves and to others?

The Impact of the Observer on the Observed

I include this account of an exercise presented by Adrian Jackson's at CARPP's conference 2006, as a dramatic representation of an important principle in research. Adrian Jackson is the director of a theatrical company 'Cardboard Citizens' working with the homeless in London. He works with political theatre that is aimed to create change.

Stage 1:

A woman stands in the stage area of the room and strikes a pose – she reaches an arm into the air and looks up towards it. The rest of us watching, call out various interpretations of what the pose could represent:

“picking apples”,

“the Statue of Liberty”

“reaching up to touch a giant's face”

“stretching after an exercise class”

With each interpretation my perception of what the pose means changes. I notice that the poser subtly responds to each interpretation with a slight movement or change of facial expression.

Stage 2.

A member of the audience, a man moves and places himself in relation to the poser: he reaches his hand out as if catching something. While he is there, the tableau looks like someone just having thrown a ball that is being caught. After a while the woman moves away, leaving the man alone on the stage, and the process starts again with the audience calling out.

Again when the second actor places himself my perception changes.

When he is left alone, the audience once call out. I notice again that the player responds very subtly to suggestion.

What struck me about this exercise was that it demonstrated the power of naming a perception to create bias. There were two aspects to this, one being that the suggestion of what might be meant by the actors position was enough to change how I saw what was being done, and presumably the rest of the audience as well. The second was that the actor unconsciously moved towards depicting what the caller had described, thus how he was perceived influenced him. Thus what was seen by me as audience was co-created between the caller and the actor.

It seems that this was an example of a common phenomenon. It showed that any one piece of information can have multiple interpretations, as demonstrated by the multiple suggestions

from the audience in regard to one pose. It takes someone to name what they see for a particular interpretation to be brought forwards it then would take a more strenuous act to see something different. The fact that the object of observation was a person who had the ability to respond was also a factor in that he or she also took on the projection of the caller.

The implication of this for a researcher of human experience is that, to name something is powerful. It suggests that we are all constantly responding to how we are seen by others, subtly moving to fulfil each other's perception and changing how we view ourselves. Thus there is no possibility of precision or pure truth in human science; there is only relationship.

APPENDIX IV – PRODUCTS ARISING FROM PROJECT

i) Workshops and Groups

List of Presentations

The following is a list of workshops and groups that I have run in the last four years. This is followed by a selection of documents relating to some of these workshops

Couples in Stepfamilies – an Experiential Exploration:

4th – 7th August 2005 - 2 hours, Association for the Advancement of Gestalt Therapy (AAGT), Amsterdam, number of attendees: 20

Stepfamily Dynamics:

July 2006 - 1.5 hours, Gestalt Association UK, Royal Holloway, Epsom, number of attendees: 4

Families of the Future: Stepfamilies:

11th August 2006 - 1.5 hours, AAGT , Vancouver, number of attendees: 6

A Day Exploring Stepfamily Relationships: (with Debbie Friedman) 10th June 2007- 6 hours, London, number of attendees: 8

Gestalt as the Research Methodology in a Project on Stepfamilies; A Therapist's journey from Practitioner to Researcher:

6th – 9th September 2007 - 1 hour, European Association for Gestalt Therapy (EAGT), Athens, number of attendees: 12

“Mix and Match” families – an Exploration of Stepfamily Situations:

6th – 9th September 2007– 1.5 hours EAGT, Athens, number of attendees: 8

Advancing Stepfamily Awareness through Psychotherapy

3rd November 2007 – 6 hours, for Association of Humanistic Psychotherapy Practitioners (AHPP), London, number of attendees 6

Stepfamily Situations – a Rich Tapestry:

9th February 2008 – 1.5 hours, UK Association for Gestalt Practitioners, London, number of attendees: 6

Love and Loyalty in Stepfamily Situations:

29th June 2008 – 6 hours, Hampstead Heath Therapy Rooms, number of attendees: 7

An inquiry into group and stepfamily dynamics:

23rd – 27th July 2008 – 1.5 hours, AAGT Manchester, number of attendees: 6

The Stepfamily Experience – Exploring Stepfamily Issues:

30th Feb 2008, 1.5 hours, Raphael Clinic. Number of attendees: 30

AAGT Conference Amsterdam 4th – 7th August 2006

Proposal for Presentation: Couples in Stepfamilies – An Experiential Exploration

I intend to present a version of the Genogram which I have developed, called the Biogram. This depicts biological parenting connections and shows how these have an impact on the couple in the stepfamily.

I will then explore with the group how a stepfamily operates and how the couple within the stepfamily is pulled by opposing loyalties and bonds including connections through the children with a parent outside the stepfamily unit. This is a strong part of the field that the couple is part of. At present I imagine doing this through re-enacting a stepfamily, although at this stage would like to keep the options open. The stepfamily could be based on a real family, someone's client, current family or family of origin, or an imaginary one.

Processing this will form the basis for discussion, which may cover the experience of being in a stepfamily, how gestalt theory provides a model for understanding stepfamily processes, why this area is important for psychotherapists and implications of family change for society. The theme of 'co-created Gestalt relationships', seems apt for the stepfamily, which is a mesh of relationships and which may not seem like a satisfying whole to many of its members.

Abstract of Workshop: Families of the Future – Stepfamilies

The individual in the stepfamily is embedded in a mesh of relationships which are often difficult. I will explore with the group how a stepfamily operates, and how stepfamily members are pulled by opposing loyalties and bonds including connections through the children with a parent outside the stepfamily unit. This is a strong part of the field that the couple is part of. Role play will form the basis for discussion which will cover the experience of being in a stepfamily, how gestalt theory provides a model for understanding stepfamily processes, why this area is important for psychotherapists and implications of family change for society.

AAGT Conference Vancouver 9th – 13th August

Bullet Points for Workshop: Families of the Future – Stepfamilies

- * I am a Gestalt therapist, supervisor and groupworker in private practice in London
- * What has brought me to this area and what I am doing now
- * I decided to go with stepfamilies, I see this as very important, there are implications for our work with clients
- * I don't like the terms 'blended' or 'reconstituted' (and why)
- * I am talking about heterosexual families – many of these issues relate to gay relationships – they are always stepfamilies
- * My work is culturally limited – basically white, middle class, European
- * Importance of biological/non-biological relationships in stepfamilies
- * I believe that thinking about the complicated dynamics formed by relationships in stepfamilies; we may revisit our theories on groups and healthy emotional development.

Quote: Stepfamilies are very common nowadays. In fact it's been calculated that 18 million people in the UK are part of a stepfamily in some way or another. That's an awful lot of us. And yet, most of us were not brought up in stepfamilies, so we don't know much about them. Furthermore, I doubt if many of us had any ambition to be a stepparent - and we've definitely had no training. Small wonder then that a lot of people today find the whole stepfamily set up very difficult. (Christine Weber www.netdoctor.co.uk)

- * In 2000/2001 over 15,000 children called ChildLine to talk about their family relationships, many of which concerned stepfamilies. A further 1,525 called about parents divorcing or separating.
- * Families are changing and new partnerships that include children from previous relationships have their own dynamics and problems.
- * My aim is to work with this experientially so that we can arrive together at some sense of what this might entail.

Stepin ASAP Workshop, London, Sunday 10th June, 2007

Plan for the Day: Stepfamily Day - Exploring Stepfamily Relationships

co-led with Debbie Friedman

10.30 Introduction

Round of names
Structure and Ground Rules

10.50 Inner focus exercise

Close your eyes and get a sense of what it is like to be here.

Now say more about what brings you here, what you hope from today and what you might fear.

11.45 Tea Break

12.00 Fantasy family exercise

Draw your fantasy ideal family. You don't need to draw beautifully, use stick figures or a symbol. What does this family feel like? Who is there? What are the main characteristics? Is there something that might symbolise this for you?

Actual family exercise

Draw the family you actually have. Think about where you are in it? And so forth (see previous exercise)

1.00 Discussion in the group

1.30 Lunch

2.45 Presentation

Use flip chart and bullet points.

3.15 Open group

Work with people on what has been evoked for them so far.

4.45 Tea Break

5.00 Assimilation

Look back over the day, discussing in pairs or threes. What has been useful and what not. What will you take back with you into your life?

5.20 Plenary

5.30 End of Day

EAGT Conference, Athens, 6th – 9th September 2007

Letter Regarding Workshop Proposal

Dear Antonia

Thank you for accepting my presentation. I am very pleased. Below is my response to your feedback.

* **Title**

I don't like my earlier title and propose this: The Gestaltist as Researcher; exploring divisions and difference in stepfamilies

* **Categories**

I find it hard to place my workshop into your categories and realise that this is because what I am suggesting does not comfortably fit into any of them but spans both main categories and two sub-categories

If you decide to place this in the theoretical category then I need to be clear that there is an experiential aspect to this. I have been thinking through which category this should fit in and realise that my presentation spans both, because that is what I am talking about in regard to the Gestaltist as Researcher. I want to show how experiential exploration is research.

* **Sub-Category**

Some people in stepfamilies are blood related and others aren't. This difference is often the root of divisions and differences between stepfamily members. Through experiential and creative exploration, these divisions can be felt and seen in a powerful way. Such exploration can be both a therapeutic technique and part of a research methodology. Therefore, I see this workshop as spanning two categories – both Society – politics – human rights and Research – Training – Professional status.

One option might be that I only focus on one aspect of the presentation, but I think there would be a loss as follows:

If I just focus on research, then I would lose showing how this applies to a research project that participants can take part in.

If I focus on stepfamily relationships then the aspect of the gestaltist as researcher would get lost.

* **Time Duration** I would like 90 minutes for this.

I would appreciate your thoughts on this.

Regards Claire

EAGT Conference, Athens, 6th – 9th September 2007

Abstract for Experiential Presentation: “Mix and match” families – an Exploration of Stepfamily Situations

Stepfamily situations are different from families where everyone is related by blood. In the process of forming a new family, stepfamily members can experience such difficult feelings as loyalty, jealousy, ownership, competition, lack of choice and fear of the new. They don't always accept each other and the conflicts that arise can be destructive. Children often resent and dislike their stepparents, adults, even when they love each other can find their partners and children's relationship difficult, and ex-partners and their families add further complications.

In this workshop participants are invited to bring their personal and client stepfamily stories for an experiential exploration. We will discover what Gestalt has to offer in understanding these situations. The workshop will be structured according to what people bring and we may use role play, freefall writing or art techniques.

Abstract for Theoretical Presentation: Gestalt as the Research Methodology in a Project on Stepfamilies; A Therapist's journey from Practitioner to Researcher

The theory that informs Gestalt practice has philosophy and values that are entirely consistent with many qualitative research methodologies. These include the recognition that research is a relationship, that knowledge is subjective, and the valuing of data that emerges from the field, as well as creative exploration as a research tool.

In my doctoral project on stepfamilies, I have been working to integrate who I am as a psychotherapist with my preconceptions of what a researcher is. This has been, and continues to be a changing and challenging process.

This presentation will chart my research journey and how Gestalt is integral to how I do research. It is aimed to encourage people to consider research as a creative and important development of their abilities; perhaps something not so different from what they are already doing – and not as difficult as they imagine.

UKAGP Conference, London, 9th July 2008

Abstract for Workshop: Stepfamily Situations – a Rich Tapestry

Difference and Diversity

Tapestry – the idea of different threads weaving together. Threads of many colours can make a beautiful pattern, or colours can clash, textures can be incompatible etc. A stepfamily is a work of art, created from out of a variety of circumstances.

Stepfamily situations are families where adults who are not the biological parents of children are in the position of a parent (i.e. stepparents) and the biological parents live separately. An increasing number of people are in these situations either as a parent, stepparent or child. However many people don't recognise that they are living in a stepfamily situation because their family doesn't look like an integrated group. This workshop will be an exploration of real stepfamily situations through discussion and experiential role play. It is likely to touch areas that are moving and thought provoking such as love, loyalty and rivalry, inclusion and exclusion, integration and difference. Participants will be asked to bring their own or their clients experiences to look at and will therefore have the opportunity for personal or supervisory work.

Stepfamilies are increasing – the fastest growing family form. The integration – or not – of difference and diversity is intrinsic to them; the difference being people of different families getting together.

UKAGP WORKSHOP – TIMETABLE

Introduction

What is my interest in stepfamilies?

What is a stepfamily?

Why are they different/difficult

10 mins

Who are you? (creating identity in small group)

Find someone to talk to about your stepfamily experience

Spend a bit of time getting to know them

Get a sense of yourselves as a pair

Give yourselves a name

10 mins

Introducing New People

Take your pair and join with another pair

Take time to notice what it feels with these new people

Introduce yourselves

Do you feel shy or reluctant to join the new group?

How do you feel towards the person you were first with?

And the others?

How are you going to tell them about your interest in stepfamilies?

What brings you here?

Stay aware of your feelings

10 mins

Losing your group

Now to of you leave your group and join with another group.

How do you feel towards the person you have left with?

And the ones you have left behind?

And the new people?

Were you someone who stayed? Or left?

Stay aware of your feelings

10 mins

In a minor way we have reproduced some of the things that happen in stepfamilies.

Discuss in whole group

Role Play

Is there a situation, either your own or a client, that you would like to explore further?

Possible interventions

Try a different position

Act out the whole story

Give each person a chance to say what they want

Do it – notice what the resistance is and speak it

Do it, even if you feel resistant. What does it take?

Feedback from UKAGP Presentations

Dear Claire

- * I am so pleased that you did not forsake your workshop to give more time to the planning group.
- * I found the group both supportive and highly challenging. I found your opening personal revelations helped greatly to create a positive dynamic in the group – the power of initial conditions.
- * The opening experiment was very rich for me and could have provided enough material for the complete 90 minutes. With no personal experience of a stepfamily situation this gave me a powerful glimpse of some of the dynamics and emotions involved. If that was what it was like in 10 minutes I am left with an impression of how difficult it must be in a real family. If not the complete workshop, I would have liked at least more time to process the opening exercise.
- * I haven't previously done much 'enactment supervision' and found this also very powerful. I felt I had a much better appreciation of the dynamics of my client's situation and an embodied sense of my client's sense of powerlessness to pull the disparate parts of his family together.
- * The small group intimacy and practical nature of your workshop contrasted perfectly for me with the cerebral nature of the large groups during the rest of the day. I wonder how much of the insights you have in stepfamilies you could bring to the task of building a new 'Gestalt stepfamily' from the existing families of GPTI etc.

Thanks for a great workshop.

David Fender³⁹

³⁹ Fender, D. (info@davidfendercounselling.co.uk) (28th July 2008) *Feedback on Stepfamily Workshop*, Personal email to C. Asherson Bartram (clairebartram@blueyonder.co.uk)

Stepin ASAP Workshop, London, 29th June 2008
Love and Loyalty in Stepfamily Situations
Comments Taken from Feedback Forms

- * I would be more interested now in an ongoing group. It felt a big jump to be a part of an intimate group so quickly. The theme I feel is a good starting place and the the day evolved naturally.
- * The information was useful though not necessarily new, though shared commonalities was new.
- * Very useful to have intimate, open debate and listen to others' experience.
- * Useful to hear others' experience. Wanted to hear more from the trainers' experience and knowledge
- * It may have been useful to have more time after role play to expand and explore the dynamics, and perhaps change roles.
- * Interesting to see similarities and differences in everyone's experiences. The role play was really powerful. Can't think of anything that wasn't useful.

AAGT Manchester, 23rd – 27th July 2008

Proposal for Workshop:
What Stepfamily Dynamics can Teach us about Group Process

Dear Convenors

I would like to offer a presentation that explores the relationship between therapy group process and stepfamily dynamics.

Small group processes are in some ways similar to those in stepfamilies. This workshop will be an exploration in the form of an open process group where participants inquire about how this statement is or isn't born out and what we can learn about both groups and stepfamilies through this consideration. The workshop will be held in the spirit of a cooperative inquiry. There will be no other agenda - the group will form and the exploration will begin.

ii) StepIn ASAP

Handout for StepIn ASAP Workshops

- * Stepfamily Situations are far more common, and affect far more people than at first might appear. They are increasingly becoming the 'norm'.
- * Loss is inevitably present and part of the formation of any stepfamily situation.
- * Children in stepfamily situations can blame themselves or think they are wrong or bad for having conflicting feelings.
- * Adults in stepfamily situations can feel guilty, ashamed or not normal for having the feelings they do and therefore avoid talking about them.
- * People in stepfamily situations often expect of themselves that they should feel equal amounts of affection towards step relations as they do towards their own biological family and blame themselves when they don't
- * People often blame problem on their stepfamily situation and forget that biological families can also be problematic.
- * Often people have an idealised 'fantasy' family and are upset when their stepfamily isn't like that.
- * Parents might confuse children's developmental problems with stepfamily problems.
- * Stepfamily Situations are broader than the stepfamily household itself. There are often people who are part of the whole situation who live elsewhere and are overlooked.
- * Stepfamily parents often have to share their children and partners with people that they feel very little for or even actively dislike. Similarly stepfamily children have to share their parents with people they may not want to have around.
- * All families family including stepfamilies are in a 'process' - so when we look at them we are catching a point in time; it's like freezing a frame in a film because the family is constantly evolving.

Handout for Workshops

Books and Resources

STEPFAMILY BOOKS

All Together Now - What to expect when Stepfamilies Get Together

This is a small book with explanation of stepfamily dynamics and suggestions for working within your own family.

Claire Salisbury and Cheryl Walters
Stepfamily Publications (1997)

Growing Up in Stepfamilies

Gorell Barnes, Thompson, Daniel and Burchardt

A study of fifty children born in 1958. *This book is a detailed study of the experiences of fifty children who all grew up in stepfamily situations.*

Clarendon Press Oxford (1998)

Becoming a Stepfamily – Patterns of Development in Remarried Families

Patricia Papernow is a Gestalt therapist from Cleveland. It is an excellent book, one of the best known in the field. It shows stepfamily development as a cycle and is very useful for therapists.

Patricia L. Papernow
Jossey Bass Publishers San-Francisco

Stepfamilies – Living Successfully with Other People’s Children

This is a relate book. Suzie Hayman has been working with stepfamilies for many years and was the presenter of a programme where she worked live with stepfamilies.

Suzie Hayman
Vermillion London (1997)

Step by Step – Focus on Stepfamilies

This book contains a very good history on

the development of stepfamilies, the law in relation to marriage and divorce and current attitudes to stepfamilies. It presents stages of development for individuals and families.

Margaret Robinson and Donna Smith
Harvester Wheatsheaf (1993)

STEPFAMILY RESOURCES

StepIn asap – Advancing Stepfamily Awareness through Psychotherapy

Psychotherapists, counsellors and psychologists working together to learn more about stepfamily situations and offering therapy, counselling, groups, and stepfamily days as well as supervision and CPD workshops to therapists and counsellors.

www.stepinasap.co.uk

Parentline Plus

This is the amalgamation of National Stepfamily Association, Parentline and the Parenting Network. It offers information and support for all parents.

www.parentlineplus.org.uk parenting helpline 0800 800 2222

Stepfamily Scotland

Has information, free publications and a helpline

www.stepfamilyscotland.org.uk
stepfamily helpline 0845 122 8655

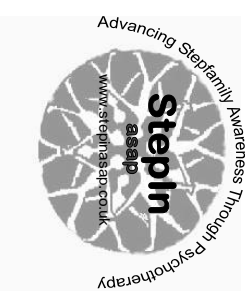

About StepIn asap

StepIn ASAP is a group of psychotherapists who work together to research stepfamily situations and increase our understanding of the issues they raise. We all work with stepfamily members and many of us have personal experience of stepfamily situations in our own families.

We hold regular meetings where we explore stepfamily issues using our therapeutic skills and experiences and sharing our knowledge. In this way we learn from and with each other

StepIn asap website is developing to be a resource for people in stepfamily situations. It contains information, writing and booklists, links to other organisations involved in this area, and has details of StepIn asap groups, workshops and research.

www.StepInasap.co.uk

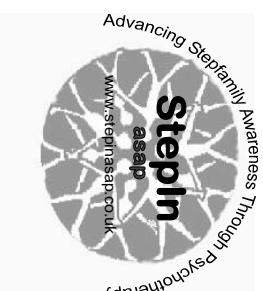

Stepfamily Awareness Through Psychotherapy

Workshop Programme 2008

Demons, Ogres and Fairy Godmothers
Managing relationships in stepfamily situations
Sunday 9th March 10.00 am – 5.30 pm

What Stepfamily Situations can Teach us
about Group Dynamics

A professional development day
Sunday 18th May 10.00 – 5.30 pm *A new look at group dynamics informed by what happens when families split and re-form.*

Love and Loyalty in Stepfamilies

The influence of biology in stepfamily situations
Sunday 29th June 10.00 am – 5.30 pm

Witches, Saints and Ordinary People

Roles and relationships in stepfamily situations
Sunday 26th October 10.00 am – 5.30 pm

All Workshops (except for the day on group dynamics) are open to parents, stepparents and people who have grown up in stepfamily situations and no previous group experience is necessary. The content of the day will be designed around the concerns and issues that participants bring. Sharing in the group will form an important part of our exploration.

Cost: £50 **Venue:** Hampstead Heath Therapy Rooms, London NW5

Why Stepfamilies?

More and more people are living in stepfamilies. Those who do often find themselves dealing with strong feelings and complicated situations they didn't anticipate. These difficulties can feel challenging, leave family members alienated and helpless, or at times openly hostile with each other.

There may be a fear that addressing the issues will make things worse, however, we have found that with time, work and goodwill they can often be resolved. In fact through the process of resolution they provide the opportunity to develop understanding of both ourselves and other people, to encompass and accept difference, and increase our capacity to love.

At best stepfamilies have the potential to become a family community; the extended family of the 21st Century.

StepIn asap members offer counselling, psychotherapy and groups to individuals, couples and families; parents, stepparents and people who grew up in stepfamilies.

We also provide supervision and run professional development workshops. (CPD certificates are available for these on request).

Our Workshops are Based on the Principal of Shared Experiential Learning

StepIn asap workshops arise from our research on stepfamilies. They aim to be experiential learning experiences where understanding is developed through creative exploration, discussion and dialogue with others.

Whether you are a practitioner or person living in a stepfamily situation we invite you to come to our workshops prepared to contribute your personal and/or clinical experiences.

Claire Asherson Bartram BA UKCP

is a Gestalt based integrative psychotherapist, supervisor and group facilitator practising in Highgate. She has a personal connection with and professional interest in stepfamilies, and has been writing, researching and running groups on stepfamily issues since 1995. **020 8361 6146**

Jon Blend MA UKCP

is a Gestalt Psychotherapist and Associate Counsellor with BUPA. He works with children, adolescents and parents at an NHS Family Consultation Service and in private practice in Acton/Ealing. Jon has a background in social work and creative and performing arts. He has a particular interest in fathering issues and enjoys being a step- parent. **020 8992 1982 S**

ue Fox UKCP, CAP

is a psychotherapist in private practise and a trainer, supervisor and group worker at the Institute of Psychosynthesis and Highgate Counselling Centre. She has many years experience of working with families and individuals who have been effected by addiction. Her interest in step families has arisen from both her personal and professional life. **0207 424 9007**

Debbie Friedman MA UKCP

is a psychotherapist working in North West London. She is a trainer and supervisor at the Institute of Psychosynthesis, London. She has a background in the creative arts, many years experience of psychotherapy and a long standing interest in stepfamily dynamics. **020 8458 5760**

Angelika Wienrich BA is a Gestalt based integrative Psychotherapist and group facilitator with 20 years experience in the field and a background in research and Higher Education. She teaches and supervises at the Gestalt Centre, London, is involved with the Healing Arts, Playback Theatre and teaches a Gestalt based approach to creative writing. She has a professional and personal interest in stepfamily issues. **020 7263 7344/ 07941156205**

StepIn ASAP, Advancing Stepfamily Awareness through Psychotherapy

Research Form

We are an organisation providing workshops and therapeutic services for people in stepfamily situations and for professionals working with stepfamily issues. We are currently developing our program and would like to respond to your views, ideas and concerns.

In order to help us with this we would be grateful if you would fill in this form. We would be happy to offer you a £10 discount on one of our forthcoming events in return.

Your comments will be appreciated even if you are not in a stepfamily situation or directly working with stepfamily issues.

In each of the following questions, please tick boxes as appropriate.

1. Do any of the following apply to you?

- I live in a stepfamily situation I grew up with stepparents
- I am a stepparent I have children who have a stepparent
- I am in an extended stepfamily situation e.g. step grandparent, inlaws, stepsiblings

I am a practitioner working with stepfamily issues Please specify capacity:.....

I am neither in a stepfamily or working with people in stepfamily situations

Other Please specify:.....

2. If you are either in a stepfamily or have worked with people in a stepfamily situation have you come across difficulties or specific issues connected with this? If so please describe briefly:

.....

3. a) If you are in a stepfamily situation and have experienced difficulties, please let us know if you have found any of the following useful

- Therapy/counselling for: individual couple family group or telephone
- Talking with friends change of situation workshops books conferences
- Information

Other please specify:.....

b) If not please tell us about this, is there anything you would have liked, or you would currently like?

.....

4. Would you be interested in any of the following resources around stepfamily issues? (either as someone in a stepfamily situation, or a professional whose clients may be in stepfamily situations)

- Counselling/therapy for yourself you and your partner Family therapy
- Therapy/support groups Seminars Workshops Talks
- Conferences Supervision Professional peer group Information
- Information for young people, schools or parents Interactive theatre event
- Other –
- Please specify

5. a) What would attract or encourage you to attend an event?
.....

b) What would (or has) put you off attending?
.....

c) Do you have any suggestions for future events?
.....

6. Any further Comments.....
.....

Would you be interested in attending a StepIn ASAP open evening? Yes No

Would you be able to distribute some of these questionnaires? Yes No

If so, let us know how many you would like.

Would you like to be on our mailing list? if so please give your details below.

Name:
Address:
.....
..... Email

Thank you for filling in this questionnaire.

What Now?

Please send the completed form by mail to: StepIn ASAP, C/o 35a Croftdown Road, London NW5 1EL

Our website with further details is: www.stepinasap.co.uk
For phone queries contact Claire Asherson Bartram, 020 8361 6146

FORMALISING STEPIN ASAP

Notes from Step In ASAP Meeting

Held on 10.3.09

Attending: Claire Asherson Bartram & Debbie Friedman

Because we have been thinking of funding, we need to make StepIn ASAP into a formal organisation. Debbie and I went through documents sent out by Fit4Funding, and the following is the outcome.

1. Organisation Check List

We need a Management Committee, that would at least have a Chair, Treasurer and Secretary. We thought this might be Claire (CB), Debbie (DF), Angelika (AW) and Brian (BC).

Management Committee: CB, AW, DF, Brian (Claire to be Chair) ask others if they would like to be members

Treasurer: Ask BC

Secretary: Ask DF or AW

Bank Account

To be set up when we know who is on the Committee

What type of Group?

We are currently an unincorporated association thinking of possibly becoming a Community Interest Company (CIC).

Constitution – . Claire is looking at adapting one from GAUK.

Equal Ops policy

If we want funding this will be necessary. It will involve a conversation about relevant Equal Ops issues to us, and then a policy written – or cribbed!

2. Aims & Objectives

Statement

StepIn ASAP arose from Claire Asherson Bartram's doctoral project on stepfamilies. She identified a need for psychotherapists and counsellors to become more aware of, and able to work with SF issues. StepIn ASAP was conceived to address this. It started in 2006 and has seven members who meet regularly.

Who are we for?

People in SF situations, psychotherapists and counsellors and others working with SF situations, Including the educational system.

FORMALISING STEPIN ASAP

What do we offer the community at large?

Information, counselling and therapy, training on SF issues and provide forums to explore and further develop understanding of SF issues in the form of: Workshops, conferences, co-operative enquiry research groups, CPD seminars, and specialised seminars for organisations. Website for everyone interested. Publicity and publications.

What do we aim to accomplish?

Raising awareness of SF issues and concerns in all areas.

Provide accessible support for SF members and professionals working with them. Continuation and development of current experiential research group. General research and networking with current researchers in the field.

How will we know if we are being successful?

- * If psychotherapy & counselling trainings include SF in their syllabus.
- * If our workshops are attended and expand.
- * Conference attendance.
- * If we're invited into organisations to run workshops and trainings.
- * If people approach us for counselling & therapy.
- * If SF issues gain exposure through our efforts and publications.
- * If the spirit of exploration and co-operative enquiry gains momentum.

Where will we be based?

In North London and online to start with.

Who are our potential customers and is there a need for our service?

We perceive and recognise a need through our work as psychotherapists.

See above for potential customers.

Are we overlapping other groups?

Some overlap but other groups not focussed on SF issues specifically:

Families Need Fathers

National Family Mediation

Parent Line Plus

Parenting UK

We could link with:

One Parent Families

Gingerbread which has merged with OPF

Parentline Plus

FORMALISING STEPIN ASAP

Possible connections with:

Gay & Lesbian families

However our service remains unique as no one specifically has this focus.

3. **Formalising our group**

We are already a group of seven who meet regularly to expand our knowledge. We have a website and a series of workshops, and the facility to supervise and receive supervision.

We are signed to be part of Terapia (child/adolescent psychotherapy training MA) as part of their CPD programme.

What we intend to do in 2010:

Launch the organisation publicly with a conference in London where we invite key figures in the field.

Out of this we will be developing workshops and seminars that can be taken into all areas of need such as: social services, schools, colleges, communities, psychotherapy training organisations, counselling services.

4. **Action Points**

- * Open up the conversation with everyone at the next meeting.
- * Because we're beginning to think of funding we need to be a bit more formal.
- * Not everyone has to be involved on committees but if there is interest that would be great.
- * This doesn't need to change what we're already developing together.
- * Talk about Conference and what we could offer in 2010.

iii) **Book Proposal**

Biography

Claire is a Gestalt therapist and supervisor in private practice, living and working in London. She works with individuals, couples, groups. She is a doctoral candidate at Metanoia Institute. (Doctorate in Psychotherapy by Professional Practice) and is researching stepfamily dynamics through the narratives of mothers in stepfamily situations.

Born in 1954 Claire grew up in a medical family in Harley Street. Her grandfather was an ear nose and throat surgeon and her father a research scientist. However she found herself drawn towards the arts and determined to follow her own interest which was definitely not medical. Claire learnt to play the flute and piano from an early age and left home to follow her passion for music by becoming a busker when she was seventeen, much to her family's disgust at the time.

She has two children and one stepson. Her first child was born when she was twenty two. Her relationship with their father was difficult from the start and she separated from her husband after nine years. It was during her break up that she first encountered psychotherapy in the form of a psychodrama group in Plymouth and psychotherapy was a significant contributor to her recovery. In fact the period of her life after she left her husband was a turning point for her. In 1985 at the age of 31, a single parent with two young children, Claire went back to education obtaining a BA honours in Music at Middlesex Polytechnic. At the same time she began training to be a Gestalt psychotherapist with the Gestalt Studio and qualified in 1991.

She began her relationship with the man who is now her husband in 1985. He had a child of his own her stepson. It was the difficulties she encountered in this situation that brought her to be interested in stepfamilies. Following her therapy training she worked on the National Stepfamily Association's counselling helpline for three years (1993-1996) and following this co-wrote with Cheryl Walters a small book 'Altogether Now – What to expect when Stepfamilies get together' (Salisbury & Walters 1997) as well as articles for humanistic psychotherapy and counselling journals (PRG 1998, Self & Society 2001,). At this time she was interested in developing psychotherapy services specifically for stepfamily members and ran a group for couples in stepfamilies that lasted for a year.

Claire is now in the process of writing up her doctoral study on mothers in stepfamilies. She has co-founded an organisation 'StepIn ASAP – Advancing Stepfamily Awareness through Psychotherapy'. This is a group of psychotherapists from various disciplines who meet to explore stepfamily issues. She continues her interest in music and has weekly flute lessons.

Summary and Overall description

The idea for this book proposal arises from my research as a doctoral candidate at Metanoia Institute. I intend to present stepfamilies in a new way and to reach specifically to therapists who work with individuals and couples; those who do not work in family therapy forums but who are extremely likely to have stepfamily members among their clients.

This book will present stepfamily issues in a readable way. It will include discussion on how stepfamily issues challenge to orthodox psychotherapy practices as they are of their nature complicated, mixed boundaried, split and so forth. They demand an acceptance of situations and working with what is rather than trying to create an ideal. Among potent themes that they raise are difference, diversity, dual relationships, boundaries, acceptance of the new and loss.

Through writing stories in the first person (based on real interviews but re-presented as a composite) I intend to present descriptions of stepfamily situations with room for the reader to make meaning of what is presented rather than to be delivered my interpretation. There will be questions and exercises at the ends of chapters will encourage readers to explore this in their practice where appropriate or with themselves. There is therefore both theory and a practical element to this book.

I aim to stimulate the reader to explore further and to bring stepfamily awareness into their work. The idea is that it will present an interactive learning experience, with some facts but plenty of material that is to be explored and questioned. This is in order to make it interesting but also to draw on the expertise of the reader and make it therefore an active and creative learning process.

It will be divided into three discreet parts. The first part will be theoretical and will cover the history and structure of stepfamilies, why they are important, the relevance of biological relationships in stepfamily situations and the role of parents and stepparents. This section will introduce 'Biograms' a version of Genograms that illustrates the underlying stepfamily dynamics.

The second part will be a series of fictional stories which will be informed by real interviews and written in the first person. Each story will demonstrate something different about stepfamilies. This will be followed by a series of questions for a practitioner to consider, a summary of key points that can be seen in the story, thoughts about what might be salient for therapists and suggestions for explorations and interventions around these areas.

The third part will bring these themes together. I will discuss groups and how stepfamily processes can be seen in group process. I will also give a scheme for running stepfamily groups. Also work with individuals and couples will be covered here.

Rationale – Intention

This book aims to be illuminative, emotionally evocative in a direct way and to encourage people to take learning about stepfamilies into their practice. It will be easy to read therefore accessible and with a minimum of jargon and difficult language. It will allow room for the reader to make meaning out of what is presented as opposed to me telling people what to think and will therefore serve the purpose of informing as well as stimulating thought and interest.

Stepfamily situations are different from families where all members are genetically/biologically related. As they are increasingly common many therapists and counsellors will find that they are working with clients who either grew up in a stepfamily situation or whose family is one now or that they are involved in their own stepfamily situation themselves. Because the proliferation of stepfamilies due to divorce is relatively recent, the situation where parents are living in separate places is now being experienced by many people but without the accumulation of knowledge that would provide a supportive road map. Complicated situations and the emergence of strong, difficult feelings are features of these situations. There is plenty of room for more knowledge and experience.

The issues that stepfamily situations raise and knowing something of what might be seen as ‘usual’ in these circumstances are important areas for psychotherapists to be aware of. For them to be able to listen and suspend judgement, to really empathise with some of the complicated and worrying feelings people have they need an embodied sense of what this is about. The type of experiential learning as offered in and encouraged by this book works towards that. It aims to be useful and informational but also is a handbook, with the intention that people use it to help them in their work; and therefore stepfamily members will be helped.

An area of interest is the critique that stepfamily situations offer towards conventional practice. They are not conventional, or uniform, they are messy and tricky. This speaks to practice – are we as therapists able to engage in messy tricky situations, or do we set up rules that make things simpler for us and our clients, but do not reflect the actualities of life.

There are already several books written on working with stepfamilies – most notably Gill Gorell Barnes (1998) on growing up in stepfamilies and Patricia Papernow (1993) ‘Becoming a Stepfamily’ which identifies different stages in the stepfamily process of consolidation. There is nothing that I am aware of written specifically with the individual, couples and group psychotherapist in mind, in the interactive way that I envisage.

Chapter Outline

The following is a draft chapter outline.

Prologue

Outlining the book content how this book came to be written. Here I will honour the influences of my parents, both now dead and my family. I will describe my research – narratives of stepfamily mothers – and work that has arisen from that.

Understanding that stepfamilies are important and different started with my experience as a mother raising her children in a stepfamily situation. It then broadened out through working on a counselling helpline. I have continued to develop working in this field.

Those who have not experienced stepfamily situations in their own families are likely to have less awareness of the challenges such situations bring. Experiential learning supports both them and others to learn through their own explorations, questions and considerations. The book will therefore hopefully raise questions more than it provides answers, leave room for the readers interpretations and offer some practical suggestions for bringing this into their work.

Introduction

A brief history of stepfamilies, an overview of other books written in the area and resources for people in this area.

SECTION 1 Background and Theory

I What is important about stepfamilies?

This chapter will set the context of stepfamilies today how do we define a stepfamily, what are the important things for psychotherapists to understand, especially those who work with individuals and couples rather than families

II Stepfamily Structure

Stepfamily structures are incredibly diverse. Working with stepfamilies is often focused on families that stay together with a view to that family consolidating. But this is not the only stepfamily situation possible.

Introducing Genograms and Biograms

SECTION 2 – Stepfamily stories

(these are suggested stories, they will almost definitely change – I intend to do five or six)

III Love and Loyalty – The story of a Mother in a Stepfamily

Christine – a mother with two children entered a relationship with a man who had a son. She describes how she felt divided between her partner and her children and felt extremely competitive with her partner's son.

Questions r:

Where do the lines of love and loyalty run?

What are the factors creating the situation for Christine?

What might the father be experiencing?

What might the children be experiencing?

Possible exploratory exercises to help Christine

IV The Enduring Relationship – the story of a Mother, her son and a series of relationships

Estelle had a son with Robert who already had children. When they separated she then had two further relationships – each with a man who had children.

Questions:

Are the issues based on Estelle's history and needs or the relationships she finds herself in?

What might the issues be for her son?

Is this a stepfamily situation? What is a stepfamily?

V Wicked Mother or Stepmother? – the dilemmas of a father

Richard's wife had post natal depression. She seemed unable to be satisfied and it was difficult for him to be involved with his adored children because of the demands of work. He divorced his wife and remarried. Because his ex wanted freedom of action the children came to live with him so that she became a stepmother. This caused problems between him and his new wife and also with his ex.

Questions:

What assumptions are made about the role of a mother?

Who was wicked or bad – was anyone? Is it a movable feast?

What are the issues for the mother? The stepmother? The children?

VI Beatrice and her Father -

Beatrice's father was alcoholic and he abandoned his family when she was seven. Her mother had several relationships during her childhood and a further two children. She is now settled. Beatrice sought her father out when she was twenty and continued in a difficult relationship with him until he died. She now has two children from two different fathers and is a single parent herself.

Questions:

What does Beatrice's story indicate about the relationship between parents and children?

How has her childhood influenced her life now?

What issues would you expect to be raised if she turned up as a psychotherapy client?

VII When she told me the truth – the story of a secret stepfamily

John's mother was pregnant when she became a partner with the man he thought was his father. John describes how he felt when he was told and how it rearranged his view of himself in his family.

Questions:

When was the best time to tell John?

What might the issues be for his mother?

His father?

VIII My huge extended Stepfamily – the story of a two times father and stepfather.

This is the story of a successfully extended stepfamily group. Not all families are able to be as interlinked as this one. It shows a particular structure.

Questions:

What are the factors that made it possible for this family to become this family group?

Did John have anything to do with it?

PART 3 Working with People from Stepfamily Situations**IX What Stepfamilies can teach us about Group Dynamics****X Working creatively to explore stepfamily situations****XI Conclusion – The issues that stepfamilies raise?**

APPENDIX V - FAIRY AND FOLK TALES

Stereotypes of Stepmothers, Stepfathers, Mothers and Fathers

Many fairy stories include a stereotypical wicked stepmother and in some cases a stereotypical good mother. Daly and Wilson (1998) suggest that the prevalence of wicked stepmothers in fairy stories shows that there are problems with stepparents worldwide. Bruno Bettelheim (1976) argues that the wicked stepmother in fairy stories represents a process whereby children split their mother into 'good mother' and 'bad mother' as a way of coping with changes of mother's mood. In this interpretation, the wicked stepmother represents that 'bad mother' thereby enabling the child to preserve a perception of mother as 'good'.

The following paragraphs from my collection of fairy stories set the scene with these characters. They introduce several wicked stepmothers, one stepfather and a few mothers.

i) Stepmother Stories

The Well at the World's End

Once upon a time, and a very good time it was, though it wasn't in my time, nor in your time, nor anyone else's time, there was a girl whose mother had died, and her father had married again. And her stepmother hated her because she was more beautiful than herself, and she was very cruel to her..... (Jacobs, 1979)

The Laidly Worm of Spindlesont Heugh (English)

In Bamborough Castle once lived a king who had a fair wife and two children, a son named Childe Wynd and a daughter named Margaret. Childe Wynd went forth to seek his fortune, and soon after he had gone the queen his mother died. The king mourned long and faithfully, but one day while he was hunting he came across a lady of great beauty, and fell so much in love with her that he determined to marry her. So he sent word home that he was going to bring a new queen to Bamborough Castle.

Princess Margaret was not very glad to hear of her mother's place being taken, but she did not repine, but did her father's bidding, and at the appointed day came down to the castle gate with the keys all ready to hand over to her stepmother.

Soon the procession drew near, and the new queen came towards Princess Margaret, who bowed low and handed her the keys of the castle. She stood there with blushing cheeks and eye on the ground and said: "O welcome, father dear to your halls and bowers, and welcome to you, my new mother, for all that's here is yours," and again she offered the keys. One of the king's knights who had escorted the new queen cried out in admiration "surely this northern Princess is the loveliest of her kind." At that the new queen flushed up and cried out: "At least your courtesy might have

excepted me,” and then she muttered below her breath: “I’ll soon put an end to her beauty.”

That same night the queen, who was a noted witch stole down to a lonely dungeon.....(Jacobs, 1979)

The Little Red Fish and the Clog of Gold (Iraqi)

Neither here nor there lived a man, a fisherman. His wife had drowned in the great river and left him a pretty little girl not more than two years old. In a house nearby lived a widow and her daughter. The woman began to come to the fisherman’s house to care for the girl and comb her hair, and every time she said to the child, ‘Am I not like a mother to you?’ She tried to please the fisherman but he always said, ‘I shall never marry. Stepmothers hate their husband’s children even though their rivals are dead and buried.’ When his daughter grew old enough to pity him when she saw him washing his own clothes, she began to say, ‘why don’t you marry our neighbour, Father? There is no evil in her and she loves me as much as her own daughter.’

They way water will wear away stone. In the end the fisherman married the widow, and she came to live in his home. The wedding week was not yet over then sure enough she began to feel jealous of her husband’s daughter. She saw how much her father loved the child and indulged her. And she could not help but see that the child was fair, and quick, while her own daughter was thin and sallow, and so clumsy she did not know how to sew the seam of her gown..... (Carter, 1991)

Brother and Sister

Brother took Sister by the hand and said ‘We haven’t had one single happy hour since our mother died. That stepmother of ours beats us regularly every day, and if we dare go near her she kicks us away. We never get anything but hard dry crusts to eat – why, the dog under the table is better off than we are, she does throw him a good morsel or two now and then. Alas, if our own dear mother only knew! Come, let us leave and go forth into the wide world together.’(Lang, 1965)

Mother Holle

Once upon a time there was a widow who had two daughters; one of them was pretty and clever, and the other ugly and lazy. But as the ugly one was her own daughter, she liked her far the best and the pretty one had to do all the work of the house, and was in fact the regular maid of all work..... (Lang, 1965)

Snowdrop⁴⁰

Once upon a time, in the middle of winter when the snow-flakes were falling like feathers on the earth, a queen sat at a window framed in black ebony and sewed. And as she sewed and gazed out to the white landscape, she pricked her finger with the needle, and three drops of blood fell on the snow outside, and because the red

⁴⁰ This story taken from Grimm Brothers is most famously known through Disney’s version ‘Snow White’.

showed up so well against the white she thought to herself, ‘Oh! What wouldn’t I give to have a child as white as snow, as red as blood, and as black as ebony!’

And her wish was granted, for not long after a little daughter was born to her, with a skin as white as snow, lips and cheeks as red as blood, and hair as black as ebony. They called her Snowdrop, and not long after her birth the Queen died.

After a year the King married again. His new wife was a beautiful woman, but so proud and overbearing that she couldn’t stand any rival to her beauty. She possessed a magic mirror, and when she stood before it gazing at her own reflection asked:

Mirror, mirror, hanging there,
Who in all the land’s most fair?’

It always replied

You are most fair my Lady Queen,
None fairer in the land, I ween’

Then she was quite happy, for she knew the mirror always spoke the truth.

But Snowdrop was growing prettier and prettier everyday, and when she was seven years old she was as beautiful as she could be, and fairer even than the Queen herself. One day when the Queen asked her mirror the usual question, it replied:

‘My Lady Queen, you are fair, ‘tis true,
But Snowdrop is fairer far than you.’

Then the Queen flew into the most awful passion and turned every shade of green in her jealousy. From that hour she hated poor Snowdrop, and every day her envy, hatred and malice grew, for envy and jealousy are like evil weeds which spring up and choke the heart. At last she could endure Snowdrop’s presence no longer, and, calling a huntsman to her, she said, ‘Take the child out into the wood, and never let me see her face again. You must kill her, and bring me back her heart, that I may know for certain she is dead.’.....(Lang, 1965)

ii) A Stepfather Tale

The Little Bull Calf

Centuries of years ago, when almost all this part of the country was wilderness, there was a little boy who lived in a poor bit of property and his father gave him a little bull-calf, and with it he gave him everything he wanted for it.

But soon after his father died, and his mother got married again to a man who couldn’t abide the little boy. So at last the stepfather said: “If you bring that bull-calf into this house, I’ll kill it.” What a villain he was, wasn’t he?.....(Jacobs, 1979)

iii) **Mother Stories**

My Own Self

In a tiny house in the North Countrie, far away from any town or village, there lived not long ago a poor widow all alone except for her little son, a six year old boy.....(Jacobs, 1979)

Tom Hickathrift

Before the days of William the Conqueror there dwelt a man in the marsh of the Isle of Ely whose name was Thomas Hickathrift, a poor day labourer, but so stout that the could do two days' work in one. His one son he called by his own name, Thomas Hickathrift, and he put him to good learning, but the lad was none of the wisest, and indeed seemed to be somewhat soft, so he got not good at all from his teaching.

Tom's father died and his mother being fond of him kept his as well as she could.....(Jacobs, 1979)

The Boy who found Fear at last

Once upon a time there lived a woman who had one son whom she loved dearly. The little cottage in which they dwelt was built on the outskirts of a forest, and as they had no neighbours, the place was very lonely, and the boy was kept at home by his mother to bear her company..... (Lang, 1965)

Fairy Tale Bibliography

Carter, A., Ed (1991). The Virago Book of Fairy Tales. London, Virago Press

Jacobs, J. Ed (1890). English Fairy Tales. (14th ed.) London, Frederick Muller Limited

Lang, A. (1963). Fifty Favorite Fairy Tales (2nd ed.) London, The Nonesuch Press